

HS series - high performance size 23 & 34 hybrid stepper motors

The high performance 23 and 34 HS series hybrid stepper motors conform to the International NEMA standard, and provide 200/400 steps/rev when used with full/half step drives but are particularly suited to microstepping operation with a wide range of drives. Supplied for unipolar or bipolar operation, the HSX series provide an exceptional torque performance in a very compact size. Both motor types are available with standard cable terminations or with a high quality connector for the 23HSX and 34HSS variants. The complete range is also available with a rear shaft extension for direct mounting of encoder or brake.

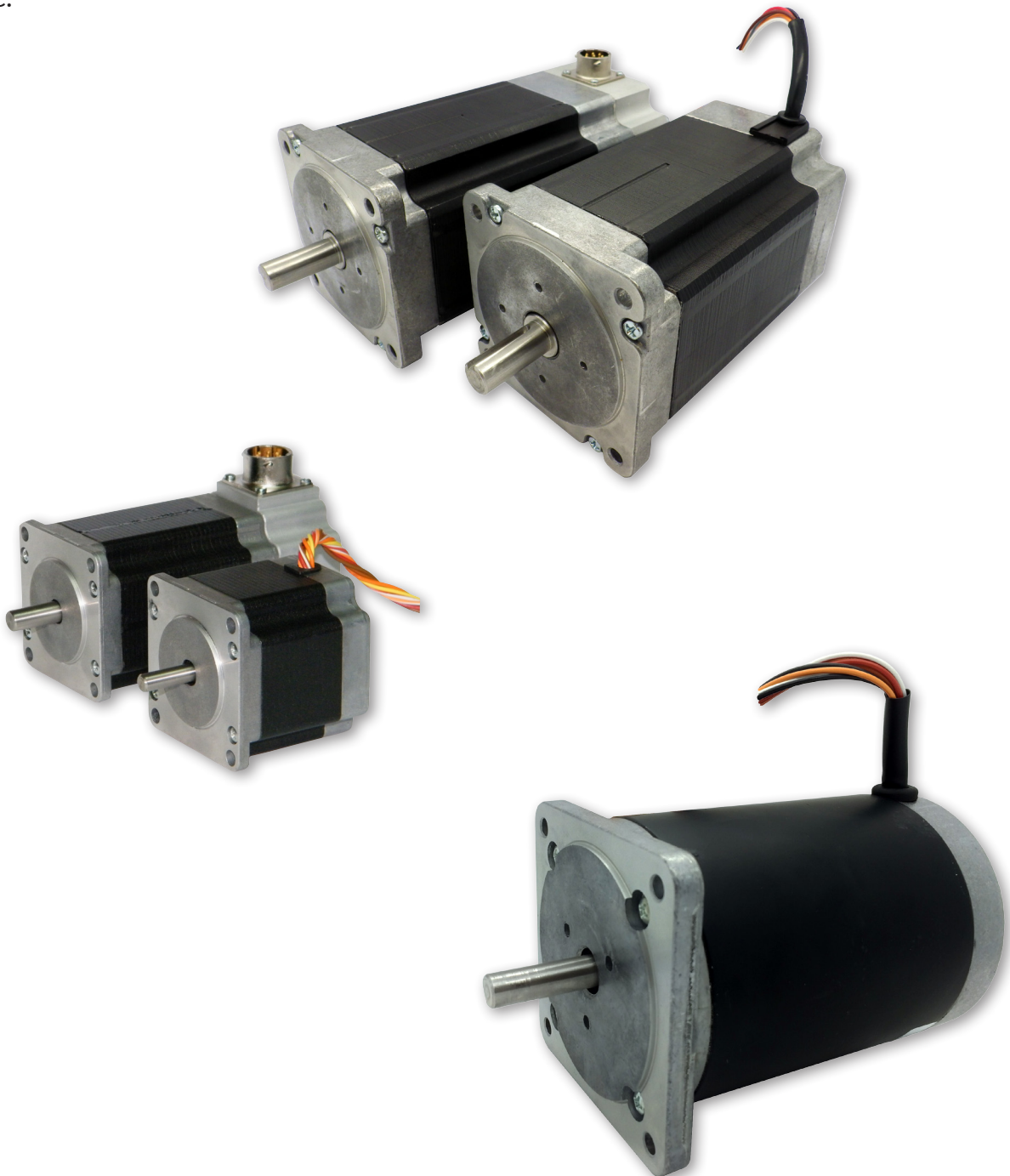



23HSX-series - high performance size 23 hybrid stepper motors

- High quality & economical prices
- High energy for increased performance
- Choice of leadwire or connector
- Choice of single or double shaft
- Optional encoder or parking brake
- Available with a choice of precision planetary gearheads for increased torque and resolution at reduced speed
- 8 connections provide the choice of Uni-polar or Bi-polar operation
- Non-standard customised executions available to special order
- Wide range of matched drives and control modules enable complete systems to be economically constructed, based on 'in-service proven' technology.

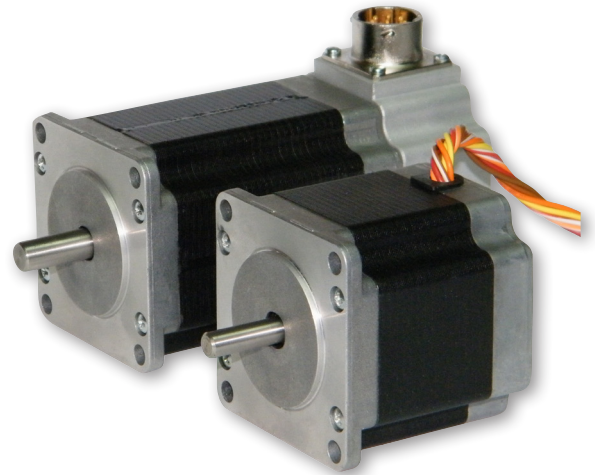

23HSX-series - electrical specification

Motor type	Unipolar operation			Bipolar operation	
	Resistance / Phase Ohms	Current / Phase Amps	Inductance / Phase mH	Current / Phase Series Connection Amps	Current / Phase Parallel Connection Amps
23HSX102	4.6	1.0	4.6	0.7	1.4 max.
23HSX202	6.2	1.0	8.8	0.7	1.4 max.
23HSX206	0.7	3.0	0.9	2.1	4.2 max.
23HSX306	1.1	3.0	1.7	2.1	4.2 max.

23HSX-series - typical performance

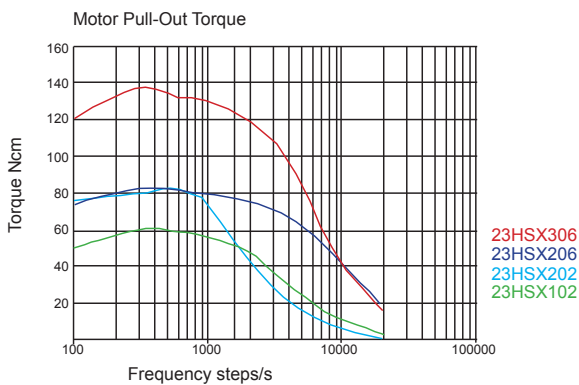

23HSX-series - performance curves bipolar operation - coils in parallel

Motor	Current per phase Amps	Rail voltage VDC
23HSX102	1.4	36
23HSX202	1.4	36
23HSX206	4.2	60
23HSX306	4.2	60



23HSX-series high performance stepper motors with flying leads - mechanical specification

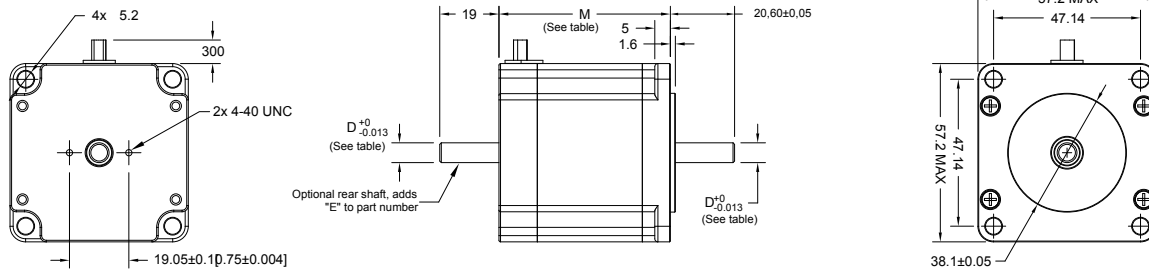

Note: Rear shaft extension may be specified by adding 'E' to part number EXAMPLE: 23HSX-206E

Phase	Wire Colour
1	Red
1'	Red/White
2'	Yellow/White
2	Yellow
3	Orange
3'	Orange/White
4'	Brown/White
4	Brown

Motor type	Motor Length M mm	Shaft Diameter D mm	Number of Leads	Mass Kg	Uni-polar Holding Torque Ncm	Bi-polar Holding Torque Ncm	Rotor Inertia Kgcm ²
23HSX102	41	6.35	8	0.5	37	47	0.077
23HSX202 23HSX206	55	6.35	8	0.7	75	98	0.22
23HSX306	78.5	8.0	8	1.0	125	163	0.34

23HSX-series series high performance stepper motors with connector - mechanical specification

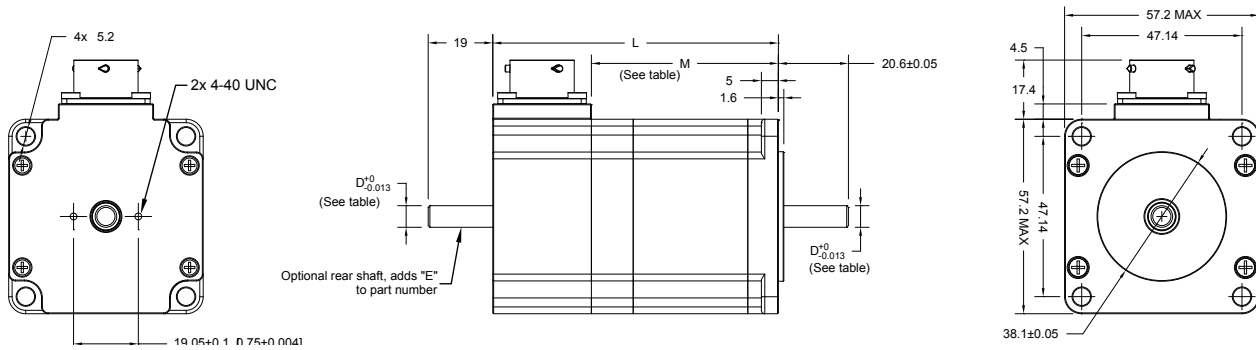

Note: Rear shaft extension may be specified by adding 'E' to part number EXAMPLE: 23HSX206CE

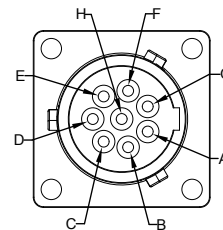

Connector pinning detail: Souriau UTO 0128PH

Phase	Pin
1	A
1'	B
2'	C
2	D
3	E
3'	F
4'	G
4	H

Motor type	Overall Length L mm	Motor Length M mm	Shaft Diameter D mm	Number of Leads/ Connector Pins	Mass Kg	Uni-polar Holding Torque Ncm	Bi-polar Holding Torque Ncm	Rotor Inertia Kgcm ²
23HSX202C 23HSX206C	84	55	6.35	8	0.7	75	98	0.22
23HSX306C	107	78.5	8.0	8	1.0	125	163	0.34

34HSX-series - high performance size 34 hybrid stepper motors

- High quality & economical prices
- High energy magnets for high performance
- Choice of single or double shaft
- Optional encoder or holding brake
- Available with a choice of precision planetary gear heads for increased torque and resolution at reduced speed
- 8 connections provide the choice of Uni-polar or Bi-polar
- Non-standard customised executions available to special order.
- Wide range of matched drives and control modules enable complete systems to be economically constructed, based on "in-service proven" technology.
- Wide range of matched drives and control modules enable complete systems to be economically constructed, based on "in-service proven" technology.



34HSX-series - electrical specification

Motor type	Unipolar operation			Bipolar operation	
	Resistance / Phase Ohms	Current / Phase Amps	Inductance / Phase mH	Current / Phase Series Connection Amps	Current / Phase Parallel Connection Amps
34HSX-108	0.55	4.3	2.1	3.0	6.0
34HSX-208	0.75	4.3	3.5	3.0	6.0
34HSX-312	0.50	6.4	2.5	3.0	8.5

34HSX-series high performance stepper motors with flying leads - mechanical specification

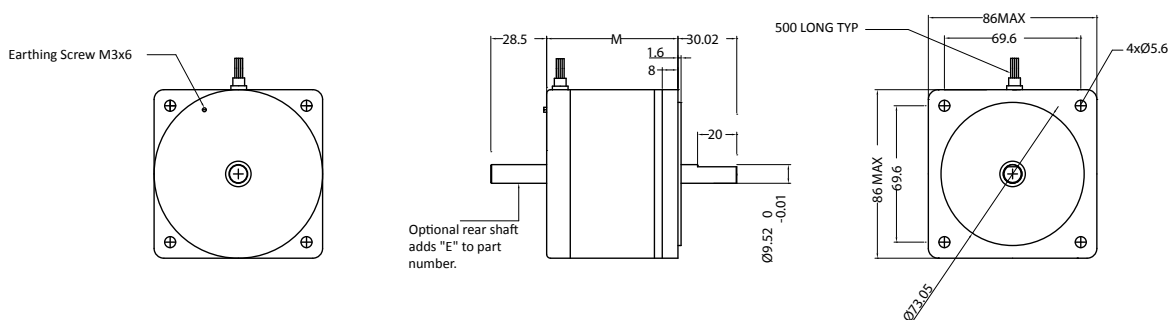

Note: Rear shaft extension may be specified by adding 'E' to part number EXAMPLE: 34HSX-208E

Phase	Wire Colour
1	Red
1'	Red/White
2'	Yellow/White
2	Yellow
3	Black
3'	Black/White
4'	Orange/White
4	Orange

Motor type	Motor Length M mm	Number of Leads	Mass Kg	Detent Torque Ncm	Bi-polar Holding Torque Ncm	Rotor Inertia Kgcm ²
34HSX-108(E)	67	8	1.6	8.5	280	0.6
34HSX-208(E)	94	8	2.4	13	480	1.2
34HSX-312(E)	125	8	3.6	23	760	1.8



34HSX-series - typical performance

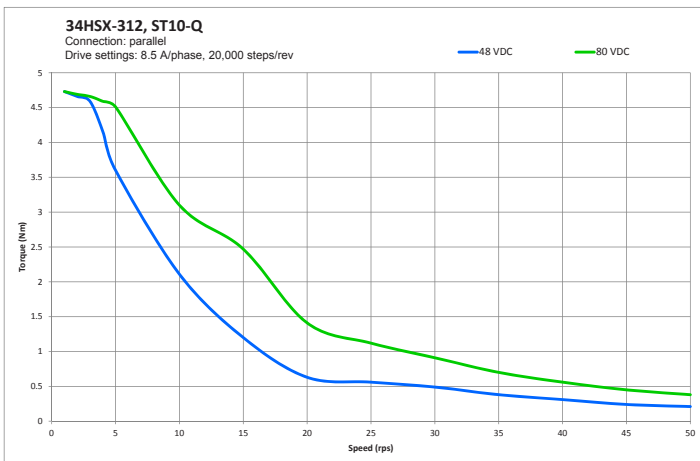
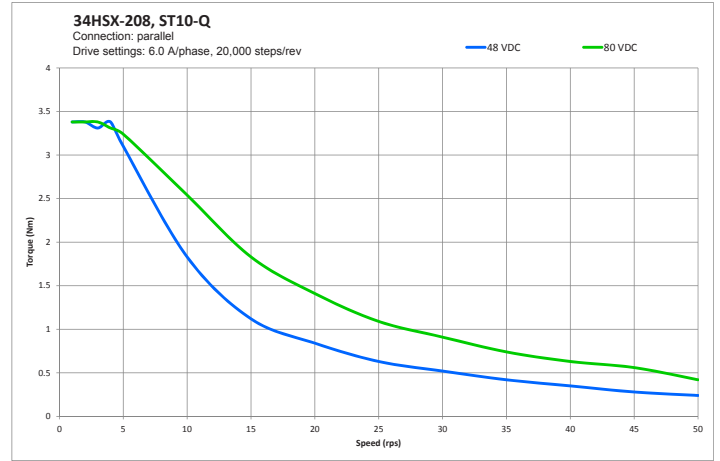
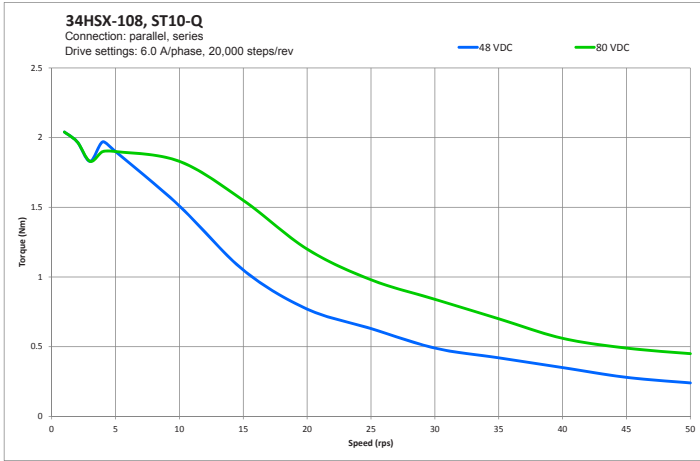

34HSS-series - high performance size 34 hybrid stepper motors

- High quality & economical prices
- High energy magnets for increased performance
- Choice of lead wire or connector
- Choice of single or double shaft
- Optional encoder or holding brake
- Available with a choice of precision planetary gear heads for increased torque and resolution at reduced speed
- 8 leads provide the choice of Uni-polar or Bi-polar
- Non-standard customised executions available to special order.
- Wide range of matched drives and control modules enable complete systems to be economically constructed, based on "in-service proven" technology.

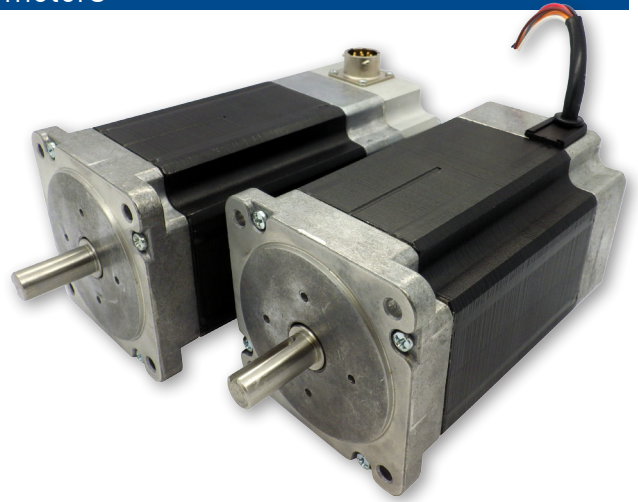

34HSS-series - electrical specification

Motor type	Unipolar operation			Bipolar operation	
	Resistance / Phase Ohms	Current / Phase Amps	Inductance / Phase mH	Current / Phase Series Connection Amps	Current / Phase Parallel Connection Amps
34HSS-106	1.40	3	6.00	2.1	4.2
34HSS-111	0.42	5.5	1.84	3.9	7.8
34HSS-206	1.50	3	6.50	2.1	4.2
34HSS-211	0.44	5.5	1.85	3.9	7.8
34HSS-306	1.75	3	9.20	2.1	4.2
34HSS-311	0.52	5.5	2.60	3.9	7.8

34HSS-series high performance stepper motors with flying leads - mechanical specification

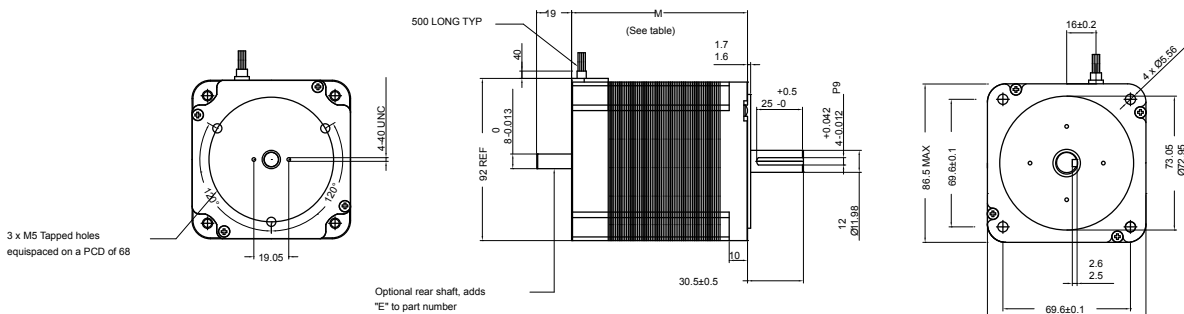

Phase	Wire Colour
1	Grey
1'	Red
2'	Yellow
2	Blue
3	Brown
3'	Orange
4'	Black
4	White

Note: Rear shaft extension may be specified by adding 'E' to part number EXAMPLE: 34HSS-206E

Motor type	Motor Length M mm	Number of Leads	Mass Kg	Detent Torque Ncm	Bi-polar Holding Torque Ncm	Rotor Inertia Kgcm ²
34HSS-106(E)	96	8	3	20	550	3.46
34HSS-111(E)	96	8	3	20	550	3.46
34HSS-206(E)	124	8	4	20	750	3.87
34HSS-211(E)	124	8	4	20	750	3.87
34HSS-306(E)	142	8	4.9	30	1000	4.90
34HSS-311(E)	142	8	4.6	30	1000	4.90



34HSS-series high performance stepper motors with connectors - mechanical specification

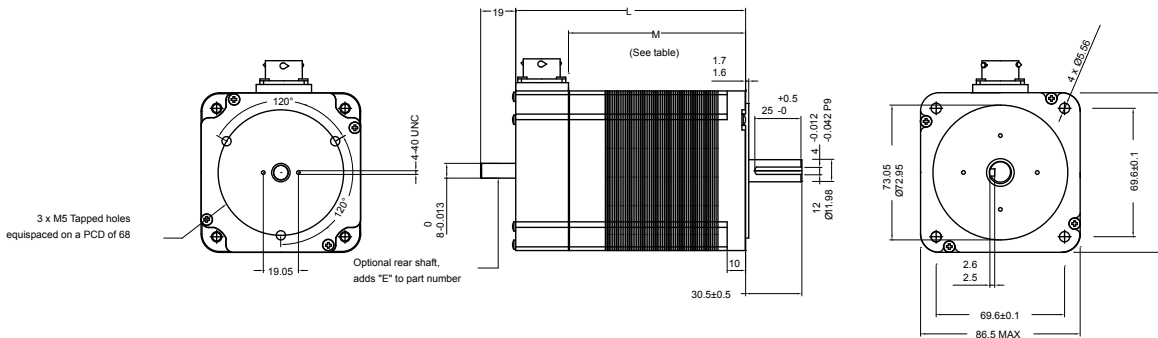

Phase	Pin
1	A
1'	B
2'	C
2	D
3	E
3'	F
4'	G
4	H

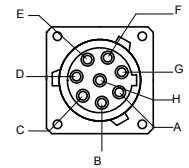

Note: Rear shaft extension may be specified by adding 'E' to part number EXAMPLE: 34HSS-206CE

Motor type	Overall Length L	Motor Length M mm	Number of Leads	Mass Kg	Detent Torque Ncm	Bi-polar Holding Torque Ncm	Rotor Inertia Kgcm ²
34HSS-106C(E)	125	96	8	3	20	550	3.46
34HSS-111C(E)	125	96	8	3	20	550	3.46
34HSS-206C(E)	153	124	8	4	20	750	3.87
34HSS-211C(E)	153	124	8	4	20	750	3.87
34HSS-306C(E)	170	142	8	4.9	30	1000	4.90
34HSS-311C(E)	170	142	8	4.6	30	1000	4.90

34HSS-series - typical performance

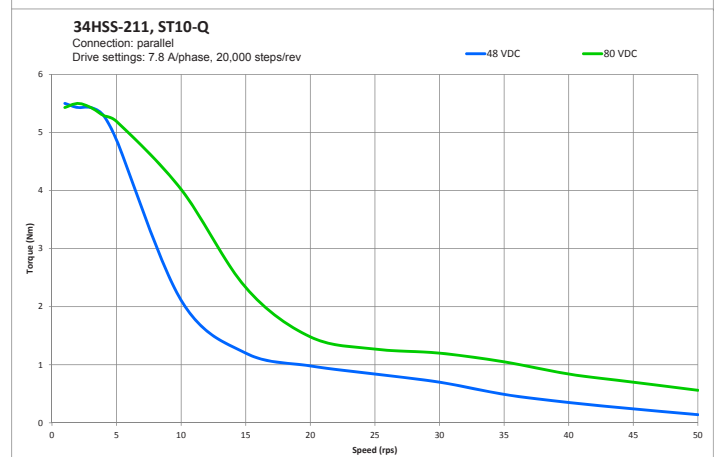
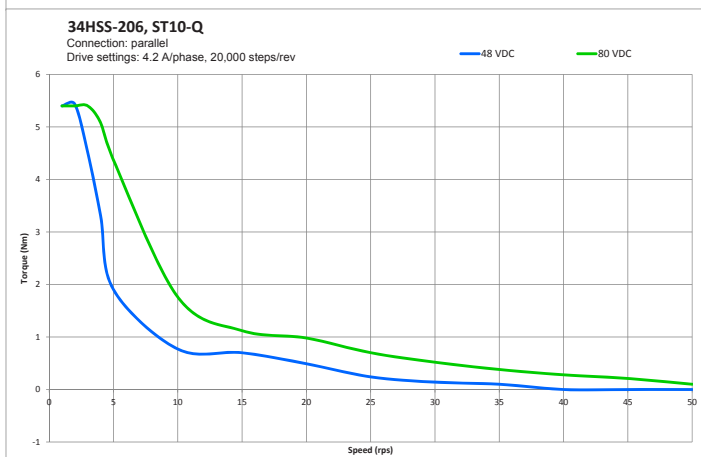
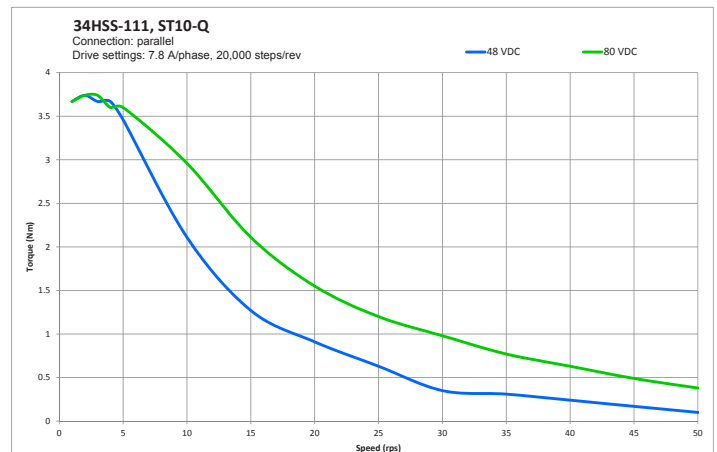
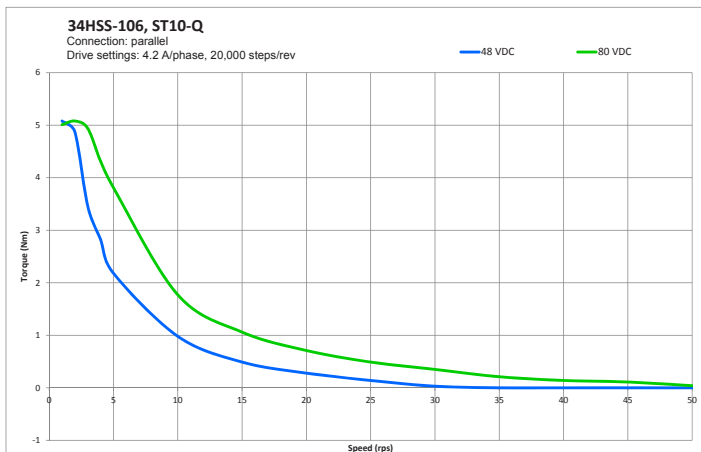

Great care is taken during the preparation of data, but McLennan cannot guarantee accuracy so it should be used for reference only



34HSS-series - typical performance (cont.)

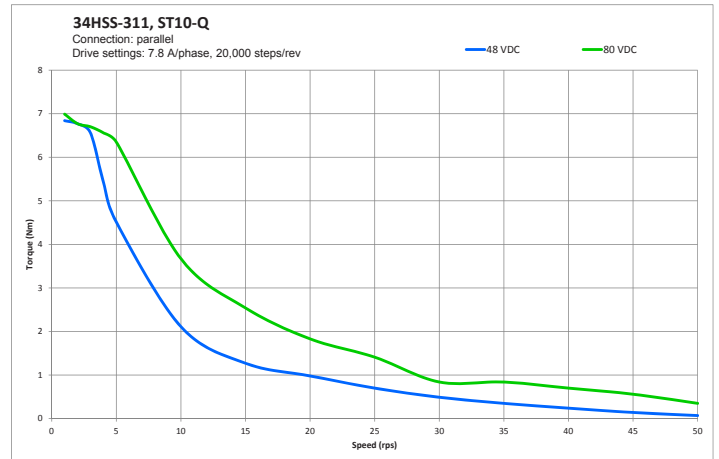
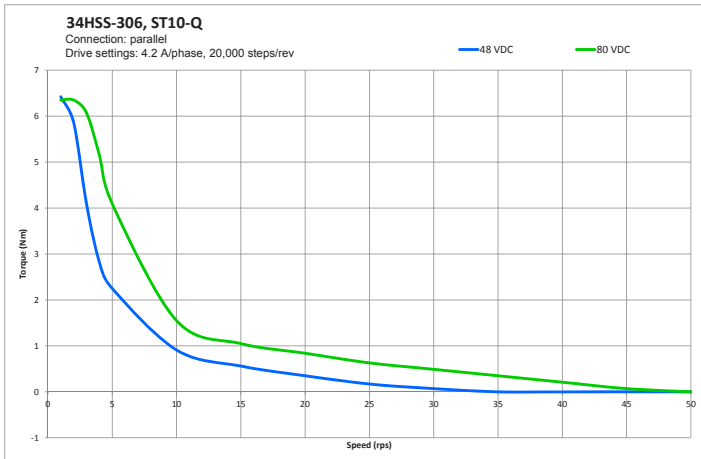

Wiring Configurations for Bipolar operation

Coils in series

8 lead motors can be connected as shown.

When operating a 4 phase motor with series connected coils the maximum allowable phase current must be reduced as follows:

$$\text{Max allowable phase current} = \frac{\text{Uni-polar rating}}{1.41}$$

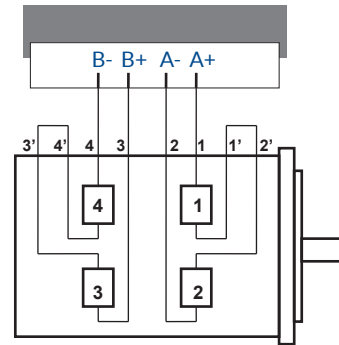

Coils in parallel

This method of connection can only be applied to motors having 8 leads. It is particularly advantageous in providing a combination of strong mid range torque and high speed operation since the effective inductance of the parallel connected winding is unchanged.

The maximum allowable Unipolar phase current may be increased as shown below.

$$\text{Maximum allowable current} = 1.41 \times \text{Uni-polar rating}$$

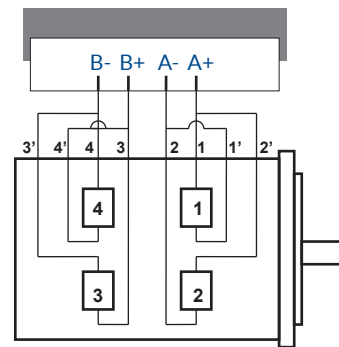

Motor	Configuration	Phase A+	Phase A-	Phase B+	Phase B-		
23HSX	Series	Red	Yellow/White Red/White	Yellow	Orange	Orange/White Brown/White	Brown
23HSX	Parallel	Red	Yellow/White Red/White	Yellow	Orange	Brown/White Orange/White	Brown
34HSX	Series	Red	Yellow/White Red/White	Yellow	Orange	Orange/White Black/White	Black
34HSX	Parallel	Red	Yellow/White Red/White	Yellow	Orange	Black/White Orange/White	Black
34HSS	Series	Grey	Red/Yellow	Blue	Brown	Black/Orange	White
34HSS	Parallel	Grey	Yellow Red	Blue	Brown	Black Orange	White



23 & 34 HS & HSX series - with encoder option fitted:

HSX and HS series stepper motors are available fitted with quadrature (RS422 line driver) encoders to provide feedback of motor position. Motors thus equipped are therefore ideally suited for use with motion systems employing closed loop controllers. The standard 'E5' encoder option has 1000 pulses per rev (4000 positions) and is supplied complete with a cable assembly.

23HSX & 34HSS with flying leads

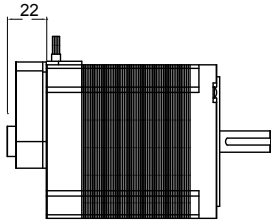

34HSX with flying leads

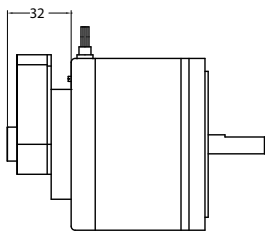

23HSX & 34HSS with connectors

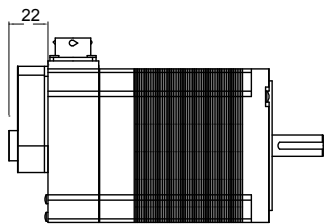

Encoder connection 10-pin differential standard

Pin	Description	Lead colours
1	Ground	Drain (connected on one end)
2	Ground	Green w/ White stripe
3	Index-	White w/ Orange stripe
4	Index+	Orange w/ White stripe
5	A- channel	White w/ Blue stripe
6	A+ channel	Blue w/ White stripe
7	+ 5 VDC power	White w/ Green stripe
8	+ 5 VDC Power	NC
9	B- channel	White w/ Brown stripe
10	B+ channel	Brown w/ White stripe

Ordering information:

23 or 34	Motor frame size
HSX	High performance neodymium magnet system
HSS	Cost effective Sumarium cobalt magnet system
Winding type	See electrical specification for motor for winding options
C	Connector option
E	Rear shaft only option

23 HSX-106-C-E

