

3.5 Amp Bi-polar stepper motor drive

MSE570 Evo 2

Features

- Bi-polar drive with pre-set drive currents up to 3.5 Amps per phase
- Increased operating voltage up to 48 V
- ½ step drive option for improved damping
- suitable for size 17, 23 & 34 frame size hybrid stepper motors
- Increased efficiency
- No heatsink required
- Reduced width (7HP)
- Single rail supply for both logic and motor
- Standard Thermal protection & condition monitoring
- Operates from external clock & direction signals
- Optional on-board oscillator circuit can be added for simple manual or PLC interfaced control
- Optional matched motherboards (MSB630 & MSB870) for connection via solder free terminals



Models:	Standard unit	Version with front panel kit
	MSE570 Evo 2	PM570 Evo 2

Motherboard options See motherboard data for connections	Version for clock / direction signal input	Version for use with PM600 controller
	MSB630	MSB870

Dimensions: mm

MSE570 Evo 2

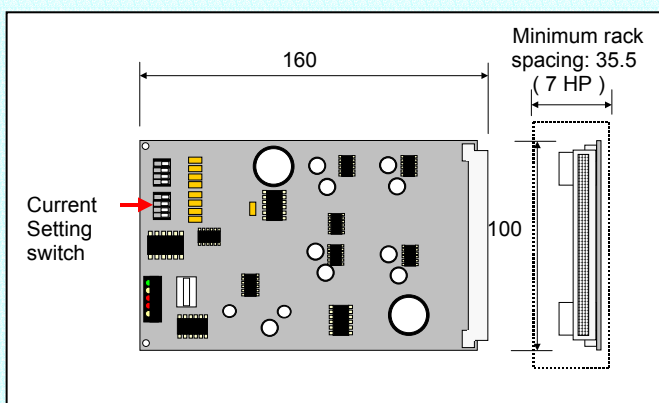

PM570 Evo 2

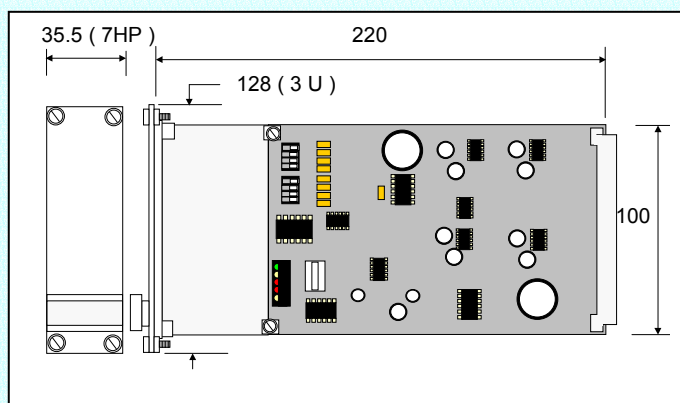

3.5 Amp Bi-polar stepper motor drive

MSE570 Evo 2

The MSE570 is a low cost high performance Eurocard Bi-polar drive designed for mounting in 3U high Euro-racks. Ideally suited for use with Nema size 17, 23 & 34 stepper motors, the unit provides a wide range of current options. Designed for use by original equipment manufacturers, the unit provides a reliable and economic in-service proven' drive solution. Furthermore, the MSE570 design enables users to customise the unit to meet their exact requirements by providing a series of up-grade options which can easily be implemented.



Improved Output stage efficiency

The MSE570 *Evo 2* features a chopped constant current output stage with on-board current settings from 0.5 to 3.5 Amps per phase to meet the requirements of virtually any 2 or 4 phase hybrid stepper motor in the Nema 17, 23 & 34 frame sizes. The use of chopped constant current drive techniques combined with the latest developments in power stage technology results in significant advances in efficiency. Furthermore, the output current may be reduced via an external input when the motor is at standstill to reduce temperature rise in the drive and the motor. The drive is designed for use with rail voltages from 15 to 48 Vdc such as MSE173 when up to 7 drives can be incorporated in a single rack together with the power supply. For high speed operation the Power supplies type MSE562 & MSE875 are recommended for single and multi axis applications depending on motor current settings.

New Features

- Increased efficiency
- No heatsink required
- Reduces width
- Increased operating voltage
- Single rail supply for both logic and motor
- Standard Thermal protection & condition monitoring

Choice of full or half step drive

The MSE570 may be set to operate in full step or half step drive. Half step drive is recommended since it provides increased resolution (400 steps/rev. using conventional hybrid stepper motors) together with improved smoothness and damping of motor resonance.

Thermal Protection

A thermal sensor is fitted to prevent overheating of the output stages. The drive may be automatically disabled on over-temperature by setting switch SW1-1 on.

Status LED's for condition monitoring

The MSE570 drive board has five status LEDs. The status LEDs provide a visual indication of drive condition. The function of each indicator is shown in the table. Surface-mount types are fitted as standard, with provision for the user to fit through-board types. These may be soldered into locations at the front edge of the board.

LED 1	Green	Power in on
LED 2	Yellow	Output is disabled
LED 3	Red	Over-temperature fault detected
LED 4	Red	Overload fault detected
LED 5	Yellow	Home phase output

Customising the MSE570 to meet individual application requirements

Choice of external or internal step control

In most applications MSE570 will be operated in conjunction with an external control source consisting of a clock pulse train to determine rate and distance together with a direction signal. Where operation off line from a control processor is required a print on the circuit board is provided for the user to add a simple voltage controlled oscillator to facilitate manual control of the motor drive system.

Specification

MSE570

Type without front panel Type with front panel		MSE570 Evo 2 PM570 Evo 2	Notes
Supply Voltage	Vdc	15-48 + 10% max.	Max ripple: 3 V peak/Peak
Current consumption	Amps	1-2.7 A	Depending on motor selected
Logic Supply Voltage	Vdc	No separate supply required	Use motor supply
Output Stage		2 Phase Bi-polar	Chopped constant current
Output current per phase	Amps	2 Phase Bi-polar 0.5 to 3.5	Chopped constant current
Step logic		Full step / half step	Set by on-board DIP switch Open circuit for full step
Control signals		CMOS Schmitt trigger	@ 12V with 10KΩ pull-up resistors & diode isolation or contact closure to 0V or open circuit
Logic 0: (Low)	Volts	0 to 2	
Logic 1: (high)	Volts	9V to 30V max.	
Monitor Outputs		Open collector NPN transistor	Referenced to 0V
Low Level	Volts	1 max.	@ 30mA max.
High Level	Volts	Open Circuit	+ 24V max.
Auxiliary outputs	Vdc	Regulated +12V @ 50mA max.	For use with on-board oscillator
	Vdc	Regulated +5V @ 50mA max.	
Thermal Protection		Standard	Automatic shutdown protection
Condition monitoring		Standard	Via 5 way LED display + outputs
Up-grade options			User fit options: refer to manual
On board Oscillator		Optional	
Dimensions	mm	100 high x 160 long x 35.5	Std. Eurocard : Use 7HP wide panel

Typical Connections

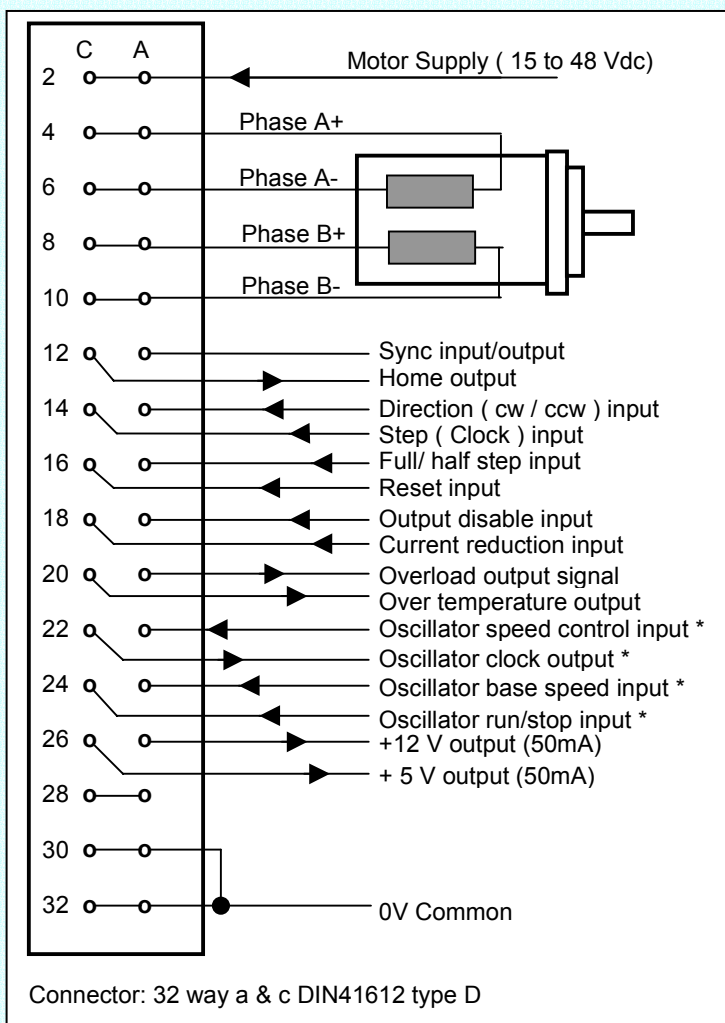

External Oscillator connections *

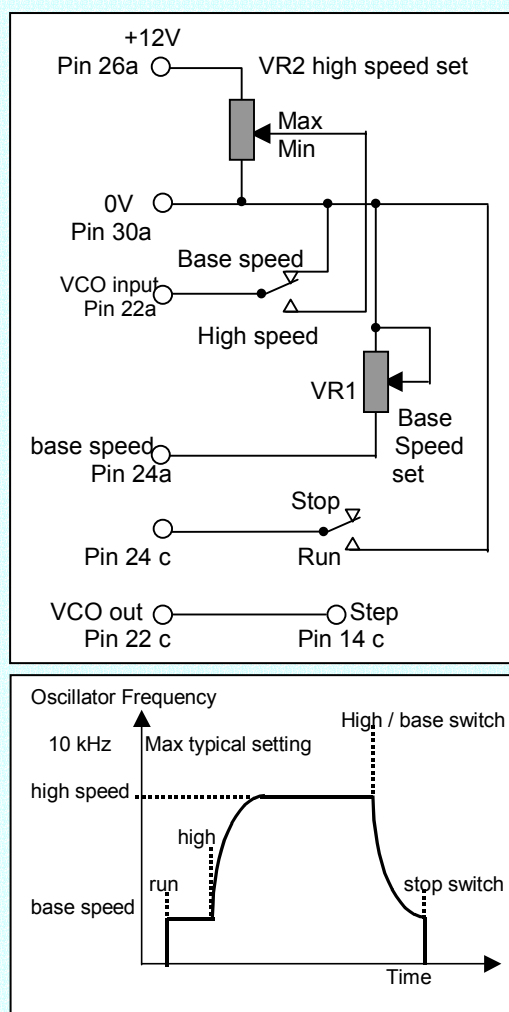

Note* Oscillator connections when circuit is fitted to MSE570 Printed circuit board

Stepper motor drive current settings

MSE570

The motor phase current can be set to suit the motor to be driven by the use of the on-board DIP switch fitted to the MSE570. The table below shows the nominal phase currents for each setting

Switch Setting				Nominal Current per phase (Amps)	Typical Motor	Motor Connections	Typical Power Supply consumption @ 36 Vdc (Amps)
SW2-1	SW2-2	SW2-3	SW2-4				
off	off	off	off	0			
off	off	off	on	0.5			1.0
off	off	on	off	0.9	17HS-020	4 lead	1.1
off	off	on	on	1.2	23HS-102	parallel	1.2
off	on	off	off	1.3	23HSX-102	parallel	1.3
off	on	off	on	1.6			1.4
off	on	on	off	1.85	17HS-240	4 lead	1.4
off	on	on	on	2.1	23HS-104	parallel	1.4
on	off	off	off	2.3	23HS-304	parallel	1.7
on	off	off	on	2.5	34HS-109	series	1.8
on	off	on	off	2.7	23HSX-202	parallel	1.9
on	off	on	on	2.9	34HS-106	parallel	2.0
on	on	off	off	3.0	34HS-209	series	2.1
on	on	off	on	3.1	23HS-309	series	2.1
on	on	on	off	3.3	34HS 109	series	2.3
on	on	on	on	3.5	23HSX-206 23HS-309 23HSX-306 34HS-109 34HS-209 34HSX-108 34HSX-208 34HSX-312	parallel parallel parallel parallel parallel parallel parallel series	} 2.7

Recommended motor-drive-connection combinations shown in **BOLD**

Rack mounting power supply

MSE562

The MSE562 is designed for mounting in a 3U high Eurorack and is ideal for use with the MSE570 drive card. The unit will power up to 2 small motor axes or a single axis using a 34HS size motor. For applications requiring multi-axis operation using a combination of motors requiring high current settings the MSE173 Power supply or MSE875 units are recommended to drive up to 4 motors.

MSE562 provides a 35 Vdc motor rail for high speed operation using the MSE570 Evo 2 drive.

Alternatively, where a motor is to be used at ultra high speed, the MSE562's 70 Vdc rail can be utilised in conjunction with a PM546 Drive



Specification

Width 142.2 mm (28E)
 Depth 220 mm
 Mounting 3U high rack installation
 Connector DIN41612 type D (32 way a & c)
 AC Supply 230 / 115 Vac 50 or 60 Hz.

Outputs:

5V \pm 0.25 V 1.5A Max 100mV ripple max.
 24V \pm 2.0 V 1.0 A Max. 2.5 V ripple max.
 35V \pm 3.0 V 3.0A Max 4.0 V ripple max.
 70V \pm 3.0 V 2.0 A Max 14.0 V ripple max.

Connections: Refer to handbook

Performance using MSE570 with alternative supply voltages

Size 17 hybrid motors:

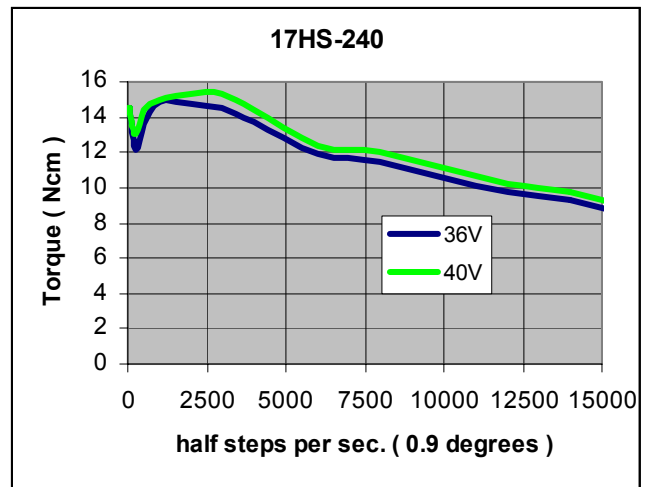
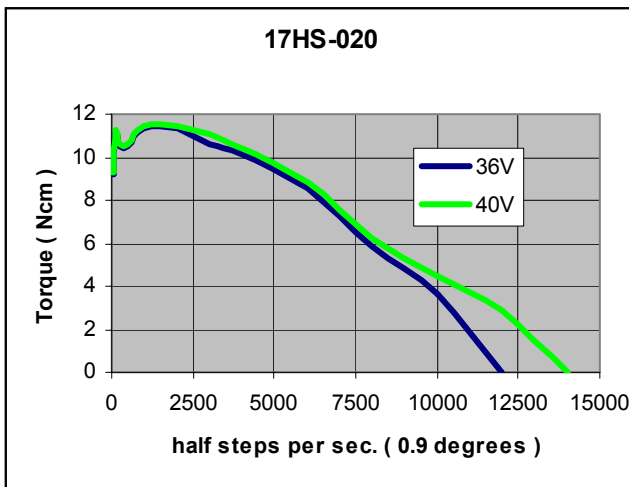

Size 23 high speed hybrid motors:

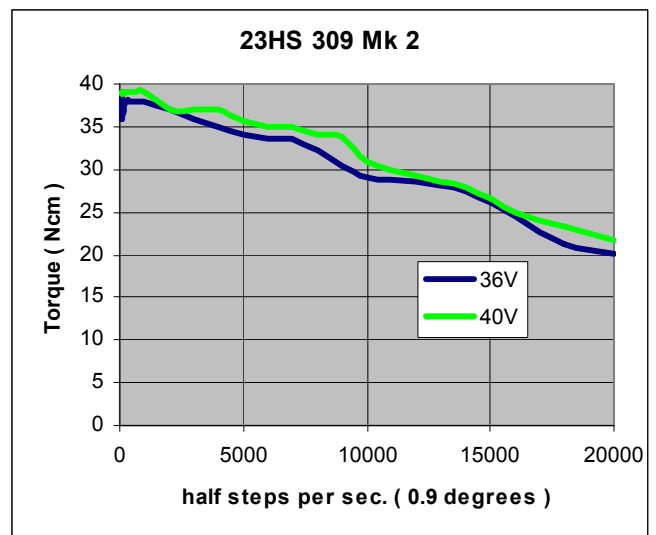
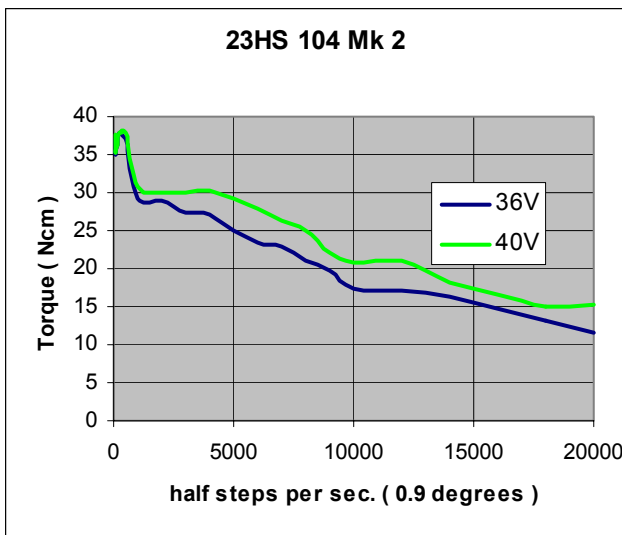

Size 34 high speed hybrid motor:

Coils in parallel, 3.5 amps per phase

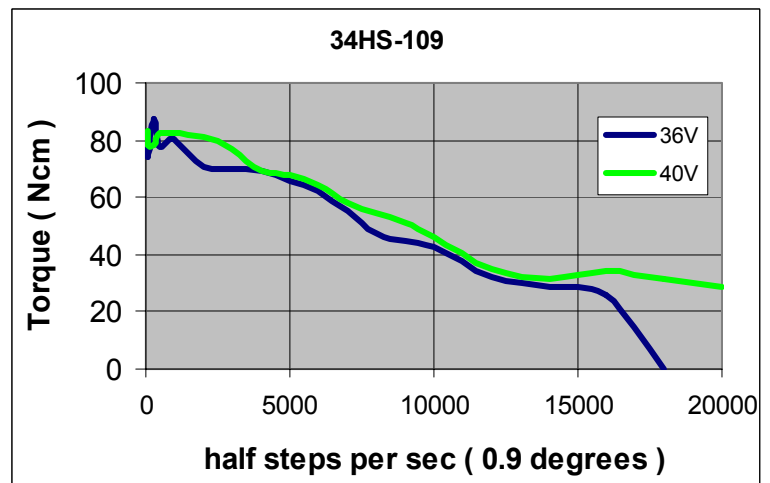

Performance using MSE570 with alternative supply voltages

Size 23 high torque hybrid motors:

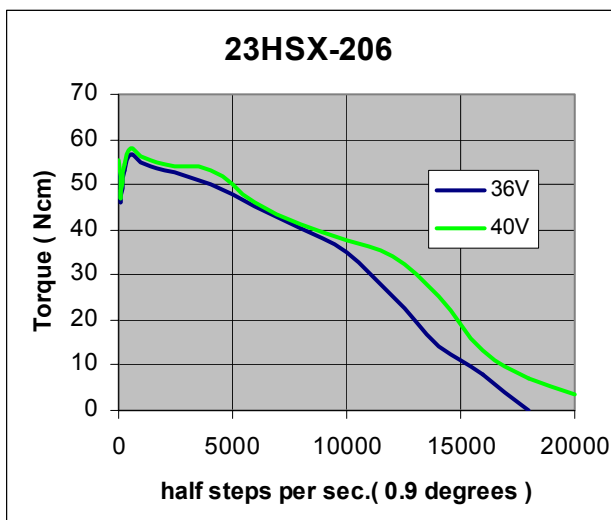

Coils in parallel, 3.5 amps per phase

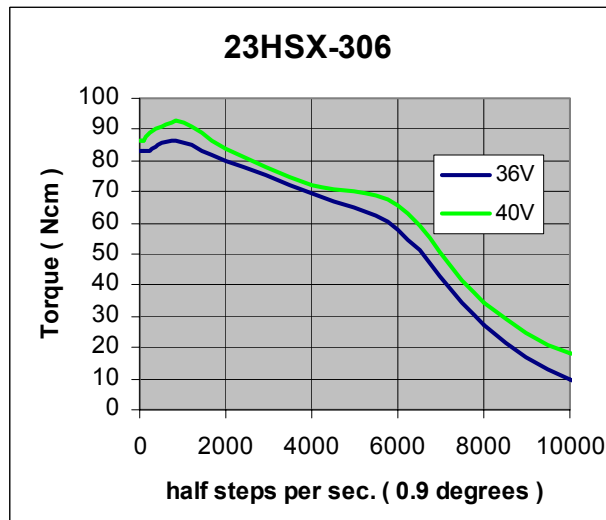

Coils in parallel, 3.5 amps per phase

Size 34 high torque hybrid motors:

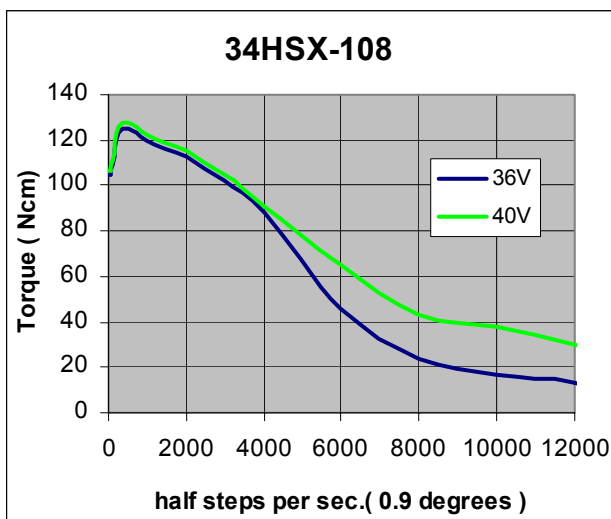

Coils in parallel, 3.5 amps per phase

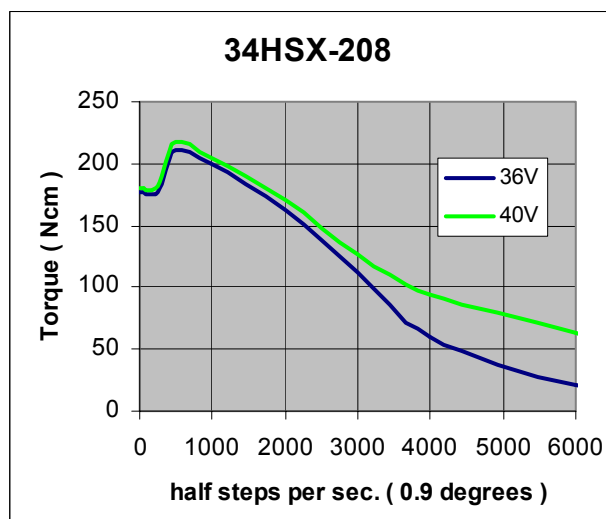

Coils in parallel, 3.5 amps per phase

Quick reference motor guide:

Size 17 motors				Size 23 high torque stepper motors			
Motor	Frame size	Length	Max Working torque *	Motor	Frame size	Length	Max Working torque *
17HS-020	42 mm	34 mm	8 Ncm	23HSX-206	57 mm	55 mm	40 Ncm
17HS 240	square	46 mm	12 Ncm		23HSX-306	square	78.5 mm
Size 23 high speed stepper motors				Size 34 high torque stepper motors			
23HS-104	∅ 57 mm	52 mm	20 Ncm	34HSX-108	∅ 86 mm	67 mm	80 Ncm
23HS-309		67 mm	30 Ncm			34HSX-208	94 mm

Note* Maximum recommended working torque to allow adequate reserve for acceleration