

# Mclennan

Mclennan Servo Supplies Ltd

Unit 1, The Royston Centre  
Lynchford Road, Ash Vale  
GU12 5PQ

Tel – (44) 08707 700 700

Fax – (44) 08707 700 699

Web – [www.mclennan.co.uk](http://www.mclennan.co.uk)

Email – [sales@mclennan.co.uk](mailto:sales@mclennan.co.uk)

## Unipolar Stepper Motor Translators User Handbook

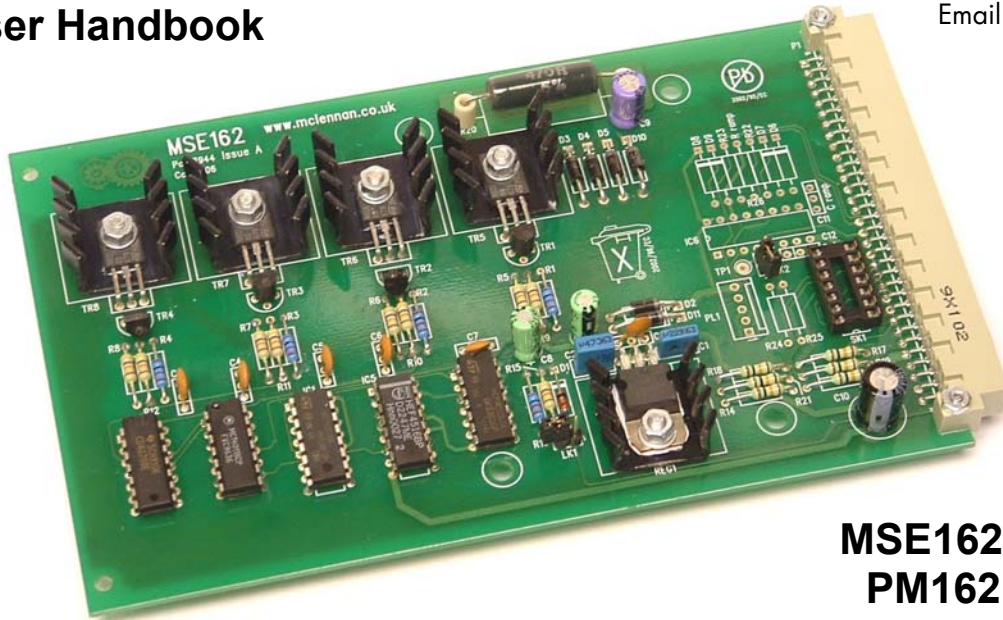

**MSE162 TM162C**  
**PM162 PM162C**  
**PVP134**

### Contents

Contents .....	1
Products covered by this manual .....	2
Control features .....	3
Internal Clock Oscillator .....	4
Starting (base) and running speed control .....	5
Oscillator frequency setting .....	6
Power Supplies .....	7
Safety .....	7
Specification .....	8
Connections .....	8
Current selection using MSE162 / PM162 .....	9
Connections for MSE162 / PM162 using external clock .....	9
Current settings using TM162C / PM162C .....	10
Connections for TM162C / PM162C using external clock .....	10

<b>Use with MSE210 Oscillator Module.....</b>	<b>11</b>
<b>Connections for oscillator module .....</b>	<b>11</b>
<b>Motor connections using twisted wires.....</b>	<b>12</b>
<b>Performance using MSE162 / PM162 with 24V supply .....</b>	<b>13</b>
<b>Performance using TM162C / PM162C with 24V supply.....</b>	<b>14</b>

## **Products covered by this manual**

### **MSE162, PM162 (& PVP134)**

#### **Features -**

- No radiated switching noise at standstill.
- Current set by external series resistors, up to 2A per phase.
- Suitable for 6 & 8 lead size 15 to 34 hybrid and permanent magnet stepper motors.
- Externally selectable full step/half step control.
- Standard 100 x 160mm EUROCARD format.
- PM162 is a standard MSE162 fitted with a front panel for fitting in a 3U rack.
- Direct equivalent to previous product EM162 and PVP134. The MSE162 encompasses all the functionality of the Alzanti PVP134.

### **TM162C & PM162C**

#### **Features -**

- Chopped constant current power stages provides increased performance reduced current consumption.
- Adjustable current settings from 0.3A to 2A per phase.
- Suitable for 6 & 8 lead size 15 to 34 hybrid and permanent magnet stepper motors.
- Externally selectable reduced current setting for operating motor in stationary condition.
- Externally selectable full step/half step control.
- Standard 100 x 160mm EUROCARD format.
- PM162C is a standard TM162C fitted with a front panel for fitting in a 3U rack.

## Control features

These economic Unipolar drives conform to the international 3U Eurocard standard. They are ideally suited for use with the 4 phase permanent magnet or NEMA size 23 & 34 HS series hybrid stepper motors with current ratings from 0.08 to 3.1 amps per phase. The ability to operate with rail voltages up to 30 V DC provide enhanced high speed performance with a choice of full step or half step phase control when improved low speed and mid range stability is achieved.

The **MSE162** utilises the L/4R drive principle. Series resistors provide the necessary current forcing to obtain improved stepping rates. The selection of an appropriate resistor value enable a wide range of motors to be driven by **MSE162** which offers the added benefit of low radiated electric noise.

The addition of a chopped constant current output stage on the **TM162C** improves system efficiency and eliminates the need for the power consuming series resistors associated with the L/4R drive arrangement. Matching the motor to the **Digitran** drive is simplified by the provision of multi-position jumpers to enable motor phase current to be set between 0.3 & 2.0 amps per phase. Motor temperature rise and system power consumption may be minimised when the motor is at standstill by use of an external switch or control output, connected to the current control input. Furthermore the motor current can be externally adjusted by means of a remote potentiometer where alternative current settings are required.

The units are controlled by clock pulses and direction signals that may either be 12V CMOS compatible for maximum noise immunity or of the open collector type. Alternatively the units may be fitted with the **MSE210** voltage controlled oscillator which provides separate control for base and high-speed settings and an internal linear acceleration ramp.

The **MSE210** oscillator is ideally suited to applications where off-line manual control of the motor is required in the event of a control system failure or as an aid to commissioning. Additionally it may be used in conjunction with a PLC based control system to provide a return to datum function or simple position control using proximity switches for motor step rates up to 1000 half steps per second.

Alternatively an on-board oscillator may be used.

## Internal Clock Oscillator

If an external clock source is not available, an on-board oscillator circuit can be assembled by soldering into place the required components as listed below. Note that the external **Clock input** (pin 24) will have to be wired to the **Clock output** (pin 17), and that **LK2** be installed.

Circuit reference	Component	Type	Quantity
R22	Metal film resistor	100K	1
R23, R24, R25	Metal film resistor	10K	3
D6 – D8	Signal diode	IN4148	4
IC6	CMOS oscillator IC	MC4046B	1
C Freq	Capacitor	Value depends on application	1
R Freq	Metal film resistor	Value depends on application	1

If remote controls are required for the oscillator (E.G. for front panel controls) then plug PL1 can be added. This will require a mating half cable shell and crimp inserts.

Connections as per the diagram below. Fig. 1  
(Alternative edge connections in brackets)

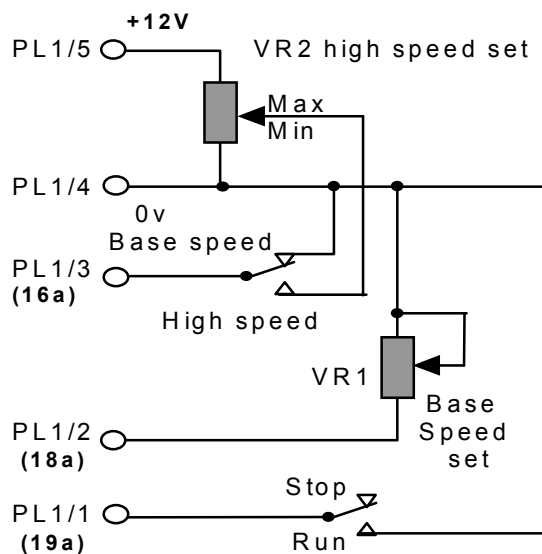

Fig. 1 External Controls using PL1

## Starting (base) and running speed control

The on-board oscillator can be arranged to start at a fixed frequency (thus a fixed motor speed) and then ramp up to a final value (the running motor speed). This facility is available to start the motor within its pull-in performance region and then accelerate the motor so that it can operate within the pull-out mode. On switch-off the motor decelerates automatically.

**Three parameters need to be determined for any application:**

- A) **The starting speed:** this should be below the pull-in speed for the motor (with any additional load).
- B) **The running (final) speed:** this should be within the pull-out capability of the motor (with any additional load).
- C) **The acceleration and deceleration rate between starting and running speeds:** this is limited by the motor capability to accelerate through its own (plus any load) inertia.

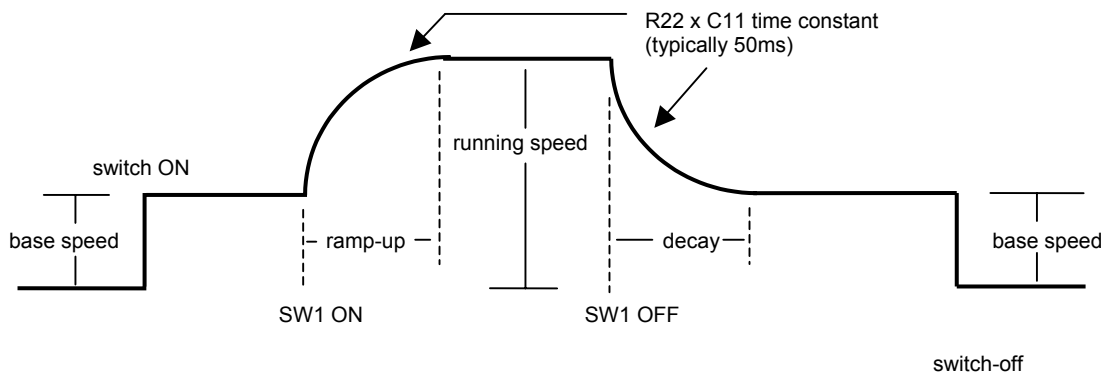

**Fig. 6 Motor speed ramping characteristic**

Note: Oscillator frequency corresponds directly to motor speed in steps per second or half steps per second depending on motor drive mode.

For a 1.8° stepper motor speed in rev/min =  $\frac{60}{200}$  x speed in steps per second

or  $\frac{60}{400}$  x speed in half steps per second

For a 7.5° stepper motor speed in rev/min =  $\frac{60}{48}$  x speed in steps per second

or  $\frac{60}{96}$  x speed in half steps per second

## Oscillator frequency setting

Recommended component values

VR1 0 – 1MΩ      VR2 1KΩ  
 RFreq 10KΩ – 1MΩ      Cfreq > 100pf

### Determine the base frequency and maximum running frequency

Using **Fig. 7** below and the base frequency value, choose a value for **CFreq** and **VR1**.

Calculate the ratio:

$$\frac{\text{max running frequency}}{\text{base frequency}}$$

to determine the ratio :

$$\frac{\text{VR1} + \text{R23 (fixed at 10K}\Omega\text{)}}{\text{Rfreq}}$$

and thus establish using **Fig 8** the required value for **RFreq**

**Base frequency (Rfreq = ∞VR2 = min)**

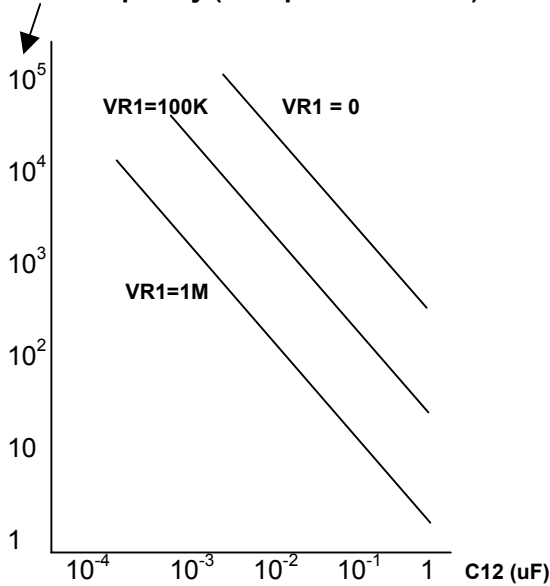

**Fig 7**

**Max running frequency / base frequency**

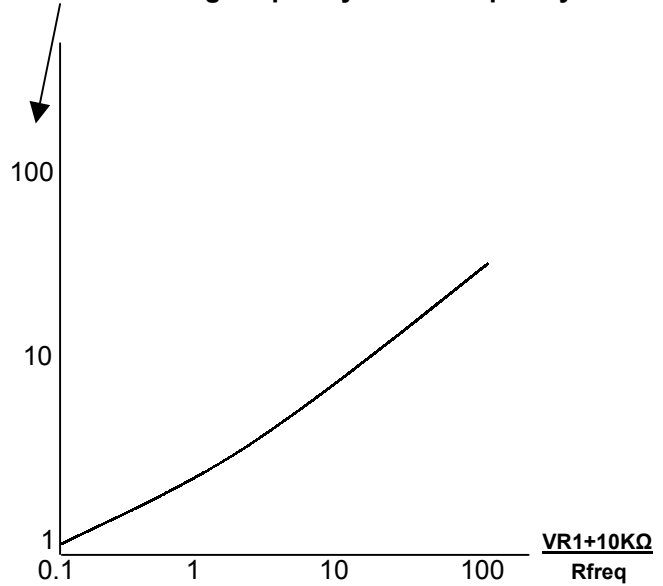

**Fig 8**

Once all component values are established and assembled, the oscillator frequency range is as shown in Fig x. If SW1 is **OFF** the oscillator runs at base frequency. When SW1 is **ON** the oscillator builds up (at a rate depending on R22 x C11 time constant), to a frequency determined by VR2 setting.

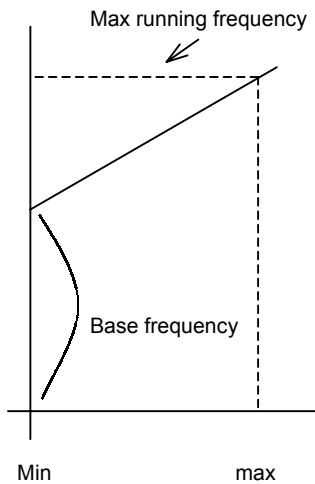

**VR2 setting  
 Fig 9.**

## Power Supplies

A range of **EM170** & **PM170** series power supply modules have been developed for use with these **Digitran** drives with the choice single or multi-axis operation at a 24 V DC motor rail voltage.

**PM170** series power supplies are 19" x 3U high eurorack mounted units with sufficient space to fit either four digitran **TM162C** drives or a two axis control system comprising **digitran** drives & **digistep** controllers. When sequential control of motor position is acceptable; a single **PM173** rack enables three **TM162C** drives to be mounted in the rack together with the **PM381** based multiplexed intelligent controller.

## Safety

### SAFETY NOTICE

**Motor drive systems are inherently hazardous. Even a small motor, if coupled to a leadscrew, gearbox, or any other form of mechanism which provides a mechanical advantage, can generate considerable force and could cause serious injury. Incorrect operation can also lead to damage to the motor or associated machinery**



**Static sensitive devices** - This unit has static sensitive devices. Observe handling precautions: Hold card by edges only. Do not touch connector pins. Ship only in anti-static packaging.



**Warning** – Mains voltages can be present within a system, do not adjust, service, dis-assemble or otherwise work on this board whilst power is applied.



In accordance with European directive 2002/96/EC on Waste Electrical and Electronic Equipment (WEEE), disposal of this item must be through the correct channels for WEEE. It should not be disposed of by landfill.

This item can be returned to Mclennan for end of life disposal under the WEEE directive, contact Mclennan for further information.

## Specification

		MSE162 PM162 PVP134	TM162C PM162C	Notes
<b>Power requirements</b>				
Motor supply	V DC	12 or 15-30	15-30	Max. ripple 3V Unregulated except 12V which must be regulated
Max. supply current	A	4	3	
Logic supply	V DC	12 or 15-30	15-30	
Max. supply current	A	0.5	0.5	
<b>Dimensions</b>				
Height	mm	100	100	Fits 3U high eurocard rack. PM versions use 12E wide front panel
Width	mm	25	50	
Length	mm	160	160	
<b>Output stage</b>				
Current control		L/R or L/4R	Chopped	
Output current per phase		0-2.0	0.08-2.0	
Current selection		Series resistors	Onboard links	
<b>Digital inputs</b>				
0 state	V	0-1	0-1	
1 state	V	10-12	10-12	
CMOS inputs, internally pulled up to 12V. Use 12V or open collector signals.				

## Connections

		MSE162 PM162 PVP134	TM162C PM162C	Notes:
				32 way DIN41612 Row A socket
<b>Power supply</b>				
Motor Supply	pin 1	pins 1&2		
12V Logic Supply	pin 27	N/A		Use one or other, not both
15-30V Logic Supply	pin 28	N/A		
0V	pins 29-32	pins 29-32		
+12V output	pin 27	pin 27		500ma max, only a with 15-30V supply
<b>Motor</b>				
Phase 1'2'	N/A	pin 3		
Phase 3'4'	N/A	pin 4		
Phase1	pins 3&4	pins 6&7		
Phase2	pins 6&7	pins 8&9		
Phase3	pins 9&10	pins 10&11		
Phase4	pins 12&13	pins 12&13		
<b>Control Inputs</b>				
Reset	pin 22			Requires LK1 connected
Direction control	pin 23	pin 23		
Clock (Step) pulse	pin 24	pin 24		Step on falling edge, 5 $\mu$ S minimum.
Step Size	pin 25	pin 25		0=Half step, 1=Full step
Current control	N/A	pin 27		0 $\Omega$ =25%, 100K $\Omega$ =100%



## Current selection using MSE162 / PM162

The **MSE162** utilises series resistors to set the motor current and improve motor current rise time using the L/4R drive principle. Typical series resistor ( $R_s$ ) values are shown below for the popular motor types at 24V DC supply:

Motor type	Rated phase current (A)	Resistor value ( $\Omega$ ) $R_s$	Resistor wattage (W)	Suitable power supply
42M100-B2U	0.16	100	6	MSE171 up to 8 axes
ID32-101	0.22	88	6	MSE171 up to 6 axes
17HS006	0.26	68	11	MSE171 up to 4 axes
M82201-P1SB	0.45	47	11	MSE171 up to 3 axes
ID31-101	0.325	47	11	MSE171 up to 3 axis
ID31-104	0.325	47	11	MSE171 up to 3 axis
L82401-P1	0.55	47	17	MSE171 one or 2 axis
ID35-114	0.6	33	17	MSE171 one or 2 axis
MV82801-P1	1.0	22	50	MSE171
17HS020	1.0	22	50	MSE171
23HS202	1.0	22	50	MSE171
23HS030	1.5	15	100	MSE171
23HS104	2.0	10	100	MSE172
23HS304	2.0	10	100	MSE172
34HS106	2.1	10	100	MSE172

## Connections for MSE162 / PM162 using external clock

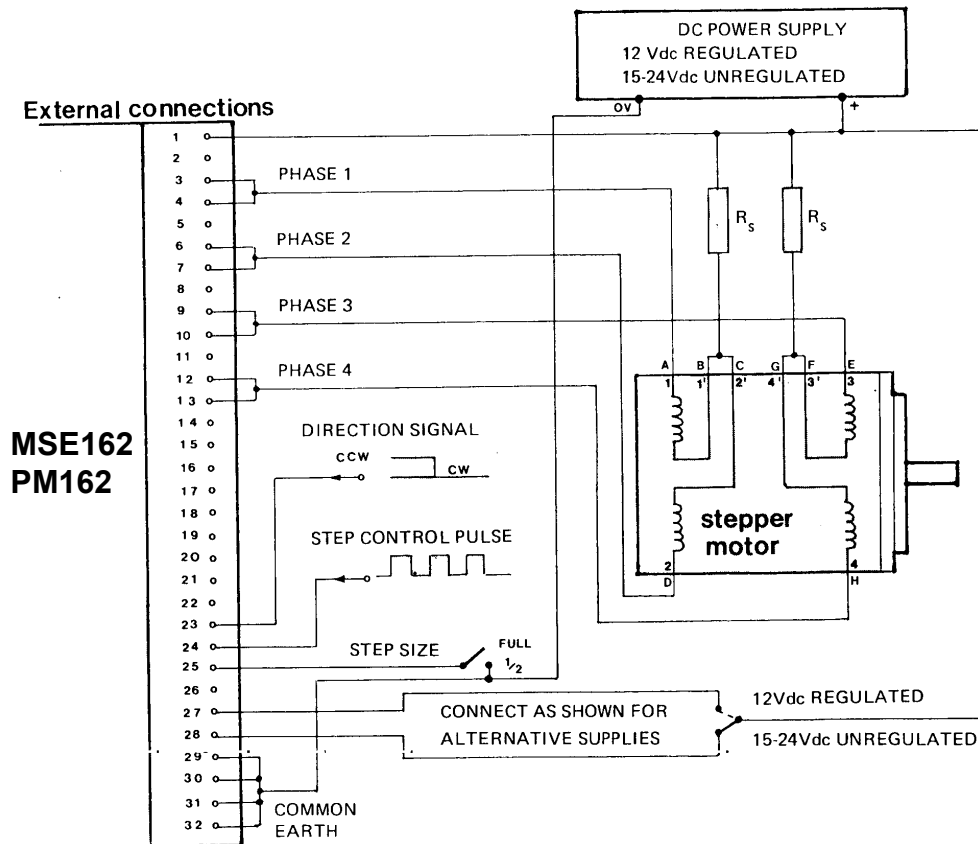

**A MSB108 motherboard is available for easy screw terminal connections and rack mounting of this unit.**

## Current settings using TM162C / PM162C

The motor phase current may be set to the most popular values using on board jumpers as shown below. Since the motor winding inductance may affect the actual current applied by the drive, the actual phase current applied to the motor should be checked during commissioning when the motor is in a stationary condition. If necessary, adjustment of the set value may be obtained by using a 100 K $\Omega$  potentiometer or a resistor connected between pin 27 and 0V. This will allow an adjustment range of between 25% and 100% of the current value set on the links.

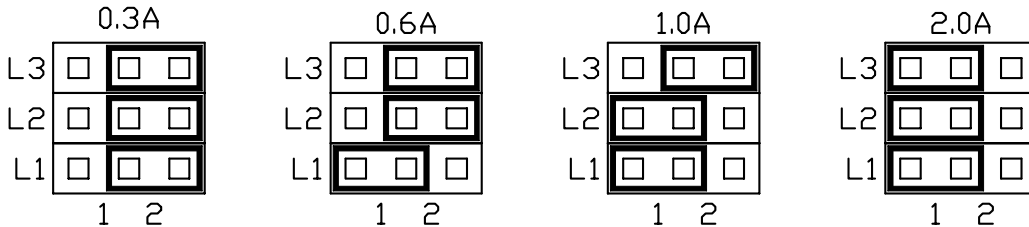

## Connections for TM162C / PM162C using external clock

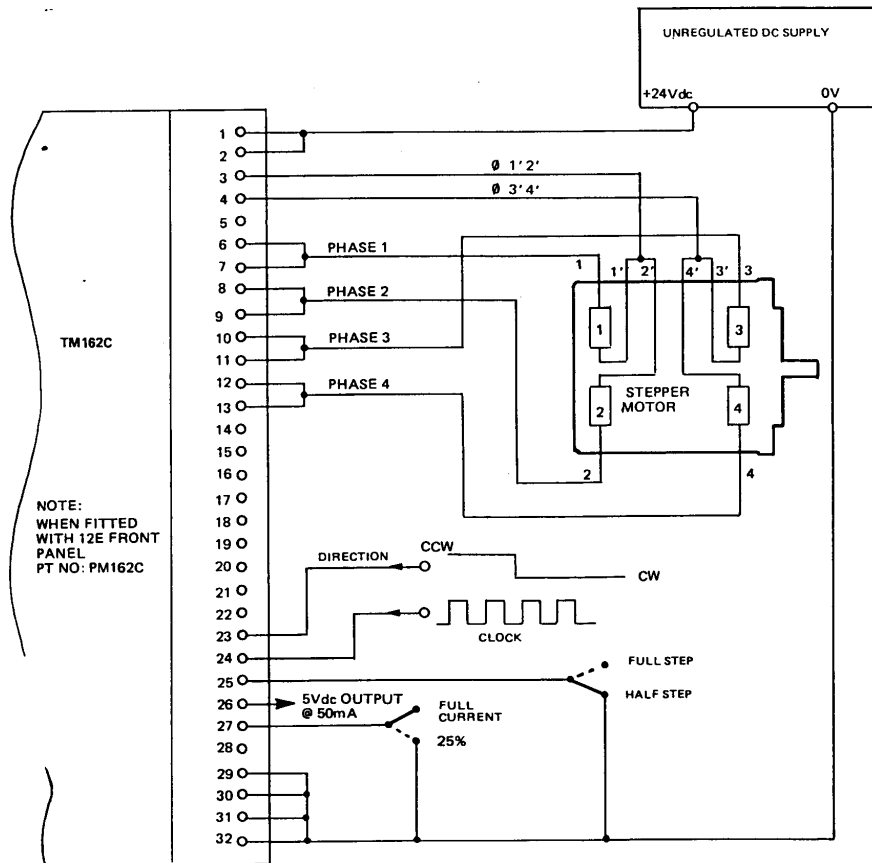

**A MSB133 motherboard is available for easy screw terminal connections and rack mounting of this unit.**

## Use with MSE210 Oscillator Module

The **MSE210** is an oscillator module for use with **MSE162**, **PM162**, **TM162C** and **PM162C** units. It has been designed to be fitted as a daughter board to the PCBs on plastic stilts and is connected via an IDC lead using the on-board connector SK1. All the control connections are then made via the host unit's 32-way connector, see Fig 10.

Two speeds may be set by external potentiometers; the base (or pull-in) speed and the high speed. These pots are fitted either externally or as preset trimmers on the appropriate motherboard.

The oscillator may be switched on or off by the Stop/Run input and the speed is selected by the Base/High input. When the speed is changed (but not switched on or off), the rate of change of speed is set by the RAMP pot on the **MSE210** board.

There is also a Jog input for single stepping the motor. Do not use this whilst in Run mode.

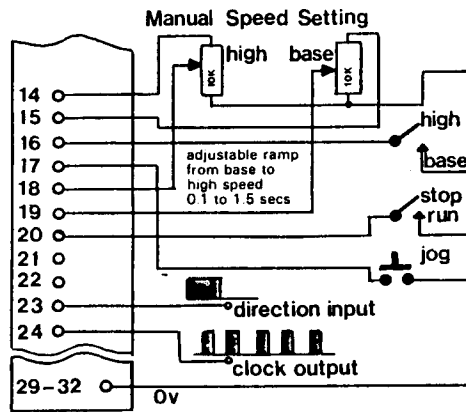

Fig. 10, Control connections with MSE210 in SK1

## Connections for oscillator module

		Notes
<b>Control Inputs</b>		
Jog input	pin 17	Pull to 0 for one step
Stop / run	pin 20	0=run 1=stop
Base / high speed	pin 16	0=high 1=base
<b>Speed Control</b>		
High speed pot feed	pin 14	10 K $\Omega$ pot to 0V
High speed wiper	pin 18	
Base speed pot feed	pin 15	10 K $\Omega$ pot to 0V
Base speed pot wiper	pin 19	

## Motor connections using twisted wires.

To produce the minimum amount of radiated noise, the motor leads should be of a twisted construction as shown below. The cable should be screened, with the screen connected to earth at the drive end and to the motor body at the motor end. In some hazardous environments, it is not permissible to earth both ends, because of the risk of high 50Hz circulating currents if the earth loop is cut by strong magnetic fields (in close proximity to very powerful electrical machinery). In this case the earth connection may be made with a  $1.0\mu\text{F}$  capacitor rated at 250VAC.

**The motor body must be earthed.**

### Motors with eight leads.

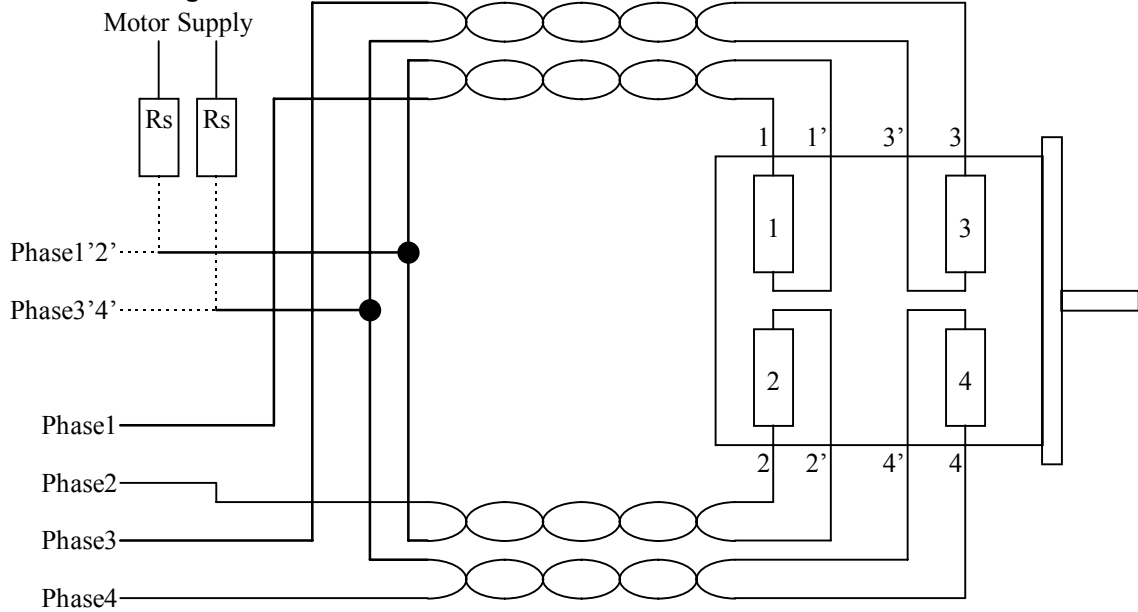

### Motors with six leads.

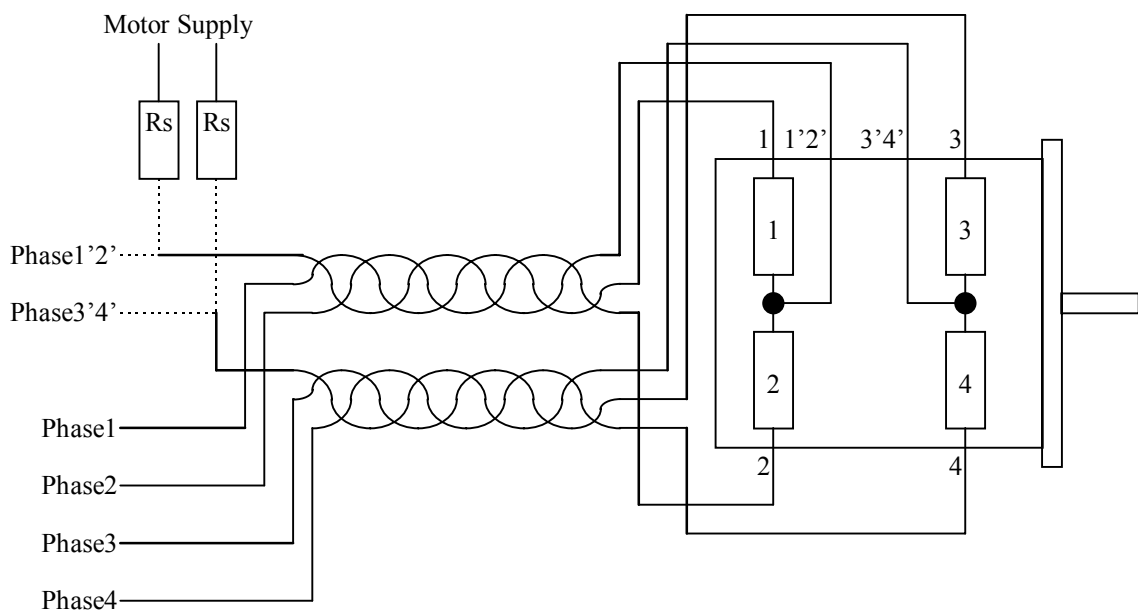

# Performance using MSE162 / PM162 with 24V supply

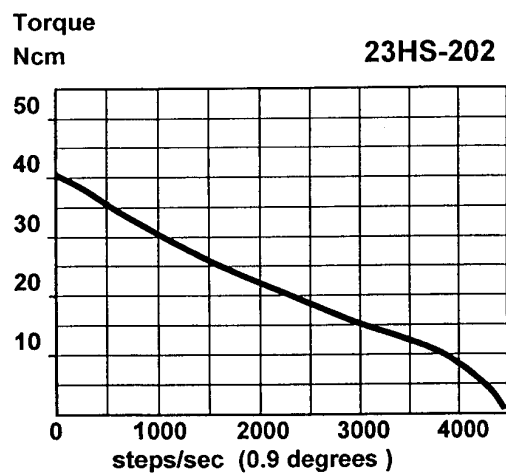
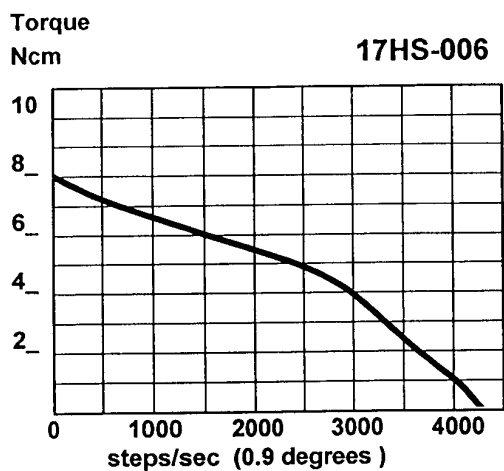
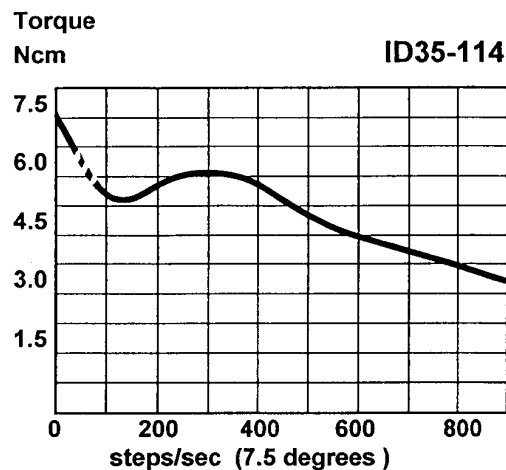
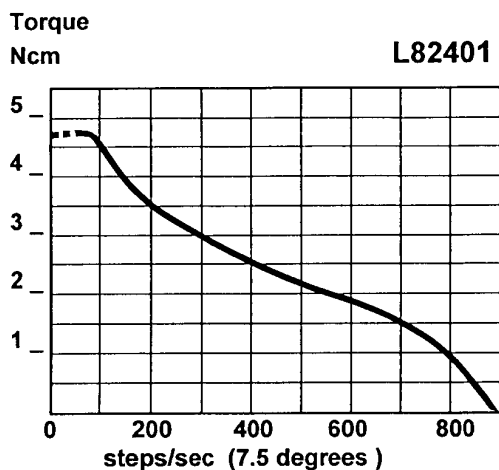
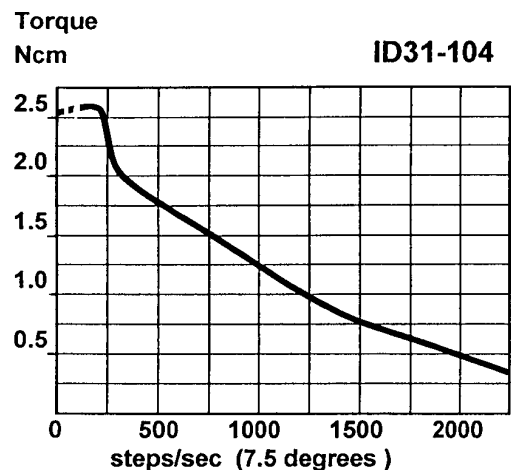
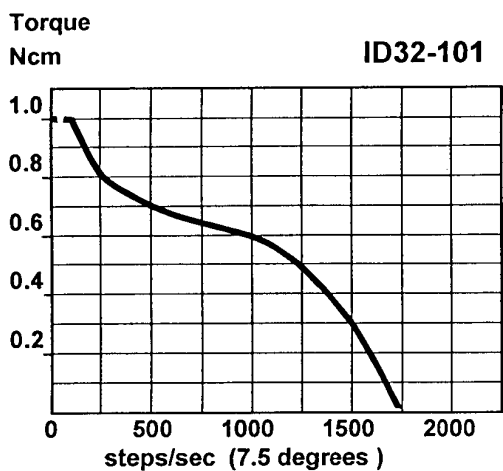

## Performance using TM162C / PM162C with 24V supply

