

BL48 EB 4 wire

Brushless DC motor

12 Watt

Dimensional drawing

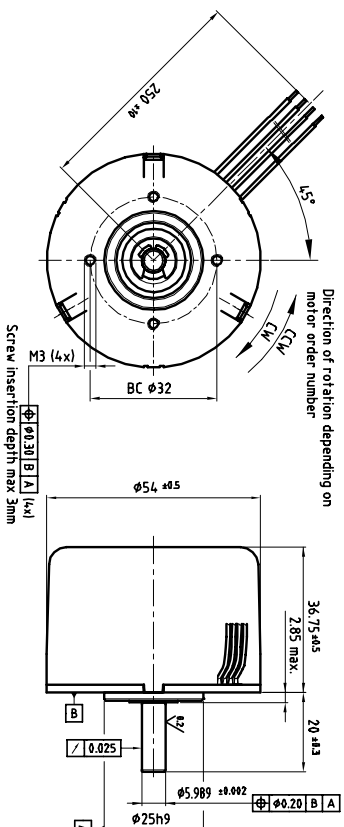

Motor data

Motor order number	CW 4322 016 *	48027	48037
CCW	4322 016 *	48023	48033
Nominal voltage	[V]	12	24
Voltage range	[V]	10...15	14...28
Max. output power	[W]	12	12
No load speed	1) [rpm]	4600	4600
Min. load current	2) [mA]	230	140
Min. starting torque	2) [mNm]	53	57
Nominal torque	2) [mNm]	30	30
Nominal speed	2) [rpm]	3200	3200
Nominal current	2) [A]	1.28	0.66
Max. current limit	1) [A]	2.13	1.04
Max. continuous torque	[mNm]	43	43
Min. adjustable speed	[rpm]	200	200
Rotor inertia	[kgm ²]	31x10 ⁻⁶	31x10 ⁻⁶
Mechanical time constant	[ms]	51	41
Max. flange temperature	1) [°C]	85	85

All relevant values in above table are valid for nominal supply voltages and Tamb=22°C
 1) For thermal reasons it is advised to mount the motor on a heat conducting frame if high output power is desired.
 2) At VCTRL=50V

Maximum radial load 15 mm from mounting front at 3000 rpm	[N]	4.0
Mass of motor	[g]	250

Performance curves

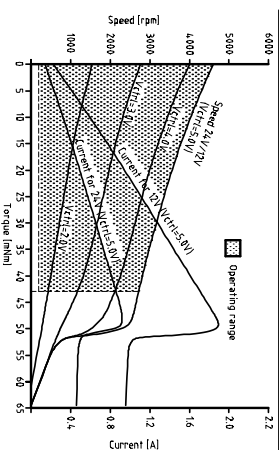

Electrical Connection

Lead colour	Signal name	Function	Size
red	+Vs	+Supply voltage	AWG 24
blue	GND	Ground (0V)	AWG 24
white	Vctrl	Control voltage input	AWG 24
green	FG	Frequency Generator output	AWG 24

Vctrl input data	
Control voltage range	[V] 0---5
Max. input voltage	[V] ±30
Threshold voltage	[V] 1.0±0.2
Speed/Vctrl relation (at no load)	[rpm/V] typ. 1250
FG output data	
FG pulses per revolution	6
Pulse length high	[ms] typ. 1.7
Output series resistance	[Ohm] 349
Output level 'high' (Iout=0.1mA)	[V] 4.2---5.4
Output level 'low' (Iout=0.1mA)	[V] <0.5

Product combinations

- * Gearbox P42A * Gearbox S67A
- * Gearbox S64A

Options

- * Special shafts, diameter 3..6 mm
- * Direction of rotation pre-set (Internal)
- * Square foot mounting Flange

Features

- * 4-wire concept with an extra lead for Frequency Generator output and a lead for speed adjustment (PWM control of motor voltage)
 - * Long life (up to 20,000 hours)
 - * EMC compliance with standards EN 55011, EN 55022 and EN 50082-1 3)
 - * Resistant against short-term wrong supply connection
 - * Input and output signals protected against wrong connection
 - * Protection class IP30
- 3) Capacitor of 1000 µF (for 12 V motor) or 470 µF (for 24 V motor) needed at the outlet of the power supply.

PREMOTEC

PRECISION MOTOR TECHNOLOGY BV
 Precision Motor Technology B.V. - Kerkeplaat 16 - 3313 LC - Dordrecht

The Netherlands - Tel.: +31 78 621 99 40 - Fax.: +31 78 621 48 28

2001-10-11 / subject to change