

21BF nuvoDisc™

8 pole

Ø21mm

4 W

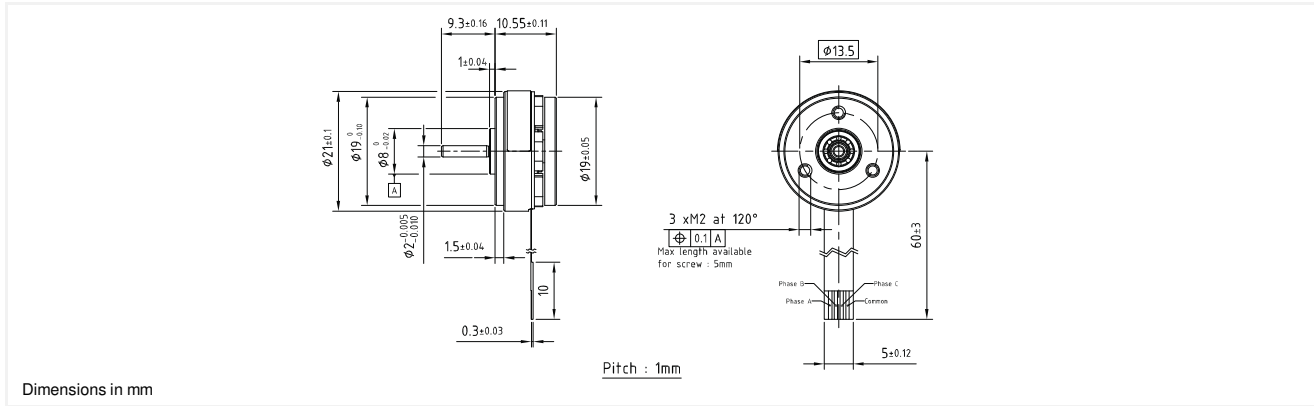

21BF 3C - **

Electrical Data	**	K	
1 Nominal Voltage	U_N	5	Volt
2 Optimization Direction	-	n.a.	-
3 No-Load Speed	n_0	3,900	rpm
4 Typical No-Load Current	I_0	28.0	mA
5 Max Continuous Mechanical Power (@25°C)	P_{max}	4.0	W
6 Max Continuous Current	$I_{e max}$	0.3	A
7 Max Continuous Torque	$M_{e max}$	2.7 (0.39)	mNm (oz-in)
8 Back EMF Constant	K_E	0.89	V/1000 rpm
9 Torque Constant	k_M	8.5	mNm/A
10 Motor Regulation	R/k^2	784.0	$10^3/Nms$
11 Motor Regulation	$k/R^{1/2}$	1.1 (0.16)	$mNm/W^{1/2}$ (oz-in/ $W^{1/2}$)
12 Internal Resistance - phase to phase	R_l	56.30	ohms
13 Line to Line Resistance at Connectors	R_L	56.30	ohms
14 Inductance Phase to Phase	L	1.22	mH
15 Mechanical Time Constant	t_m	141.2	ms
16 Electrical Time Constant	t_e	0.02	ms

General Data			
17 Maximum Motor Speed	n_{max}	25000	rpm
18 Ambient Working Temperature Range	-	-30 to +80 (-22 to +176)	°C (°F)
19 Ambient Storage Temperature Range	-	-40 to +80 (-40 to +176)	°C (°F)
20 Ball Bearings Preload	-	2.70	N
21 Axial Static Force w/o Shaft Support (max)	-	27.00	N
22 Maximum Winding Temperature	-	125 (257)	°C (°F)
23 Thermal Resistance	R_{th1}/R_{th2}	12.00	°C/W
24 Thermal Time Constant	t_w	200.00	s
25 Weight	-	10 (0.36)	g (oz)
26 Rotor Inertia	J	1.80	$g \cdot cm^2$
27 Hall Sensor Electrical Phasing	-	NA	Electrical °

sensorless	
Wire	Description
Common connection	center point of Y winding

