



ENG www.phytron.eu/ZSH

HARSH

ZSH Stepper Motor

Robust. Powerful. Reliable.



Phytron's HARSH-Environment motors are particularly suitable for challenging applications in mechanical engineering and industry. Challenging conditions are solved with the precise running performance, high torque and the motor's robust design for environments up to IP68. Inside climate chambers, adjusting the paper thickness in paper machines,

adjusting rotor blades in aviation or directly in a fuel tank: In those and other environments Phytron's stepper motors and controllers for HARSH Environments provide precise and reliable work.

In Focus



high precision



temperature



smooth running

- 2-phase hybrid stepper motor
- Number of steps: 200 / step angle: 1.8°
- Standard version: 4-lead, parallel windings, with terminal box
- Holding torques from 0.45 to 17 Nm
- Protection class: IP 54, optional: IP 68
- Permiss. ambient temperature: -30 to +50 °C (optional: +80 °C) (up to 100 °C for short time)
- Design voltage: 250 V_{AC} acc. to EN 60034
- Insulation class F acc. to VDE 0530
- Test voltage: 1800 V_{AC} (1 sec)
- High permissible axial and radial bearing loads
- Step accuracy: ±3 % (ref. to 1.8° step angle, not cumulative)
- Optional:
 - 2nd shaft (IP 41)
 - Free wire ends (IP 41)
 - Different types of flange and shaft (mm or inch)
 - Motor brake
 - Encoder
 - Low-backlash planetary gear

Highlights

IP68

The ZSH stepper motor convinces with its robust housing with high-strength cable gland. The motor is waterproof up to 10 m with the IP68 option.



temperature

Extended Temperature Range

The ZSH stepper motor not only convinces with a very balanced, smooth and low resonance running performance with maximum positioning accuracy, but also with the optional extended ambient temperature range of -30 to +80 °C (briefly up to 100 °C).



Options

Overview: Extensions

- Stepper motor with brake: Permanent magnet brake for 24 V_{DC} supply
- Stepper motor with encoder: Resolution 50, 200 or 500 lines, 2- or 3-channels
- Stepper motor with encoder and motor brake
- Stepper motor with low-backlash planetary gear: 1-, 2- or 3-stages, Reduction ratios from 3:1 to 512:1

Dimensions Stepper motor ZSH 57 to ZSH 107 / Key / Flange / Shaft

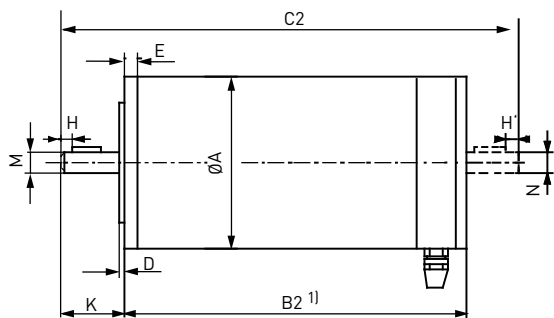

Standard: ZSH with terminal box

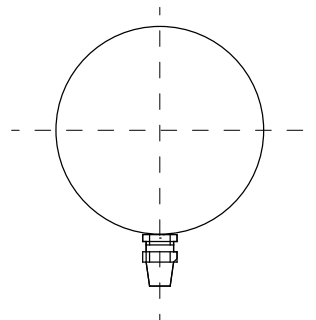

Rear View: Motor with terminal box

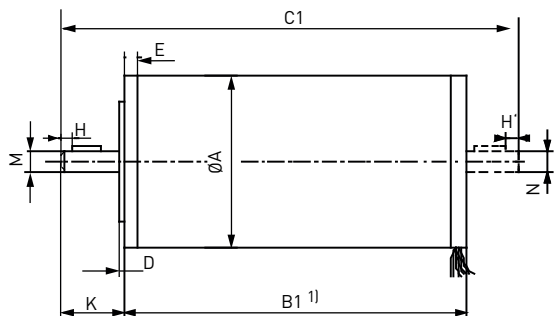

Option: ZSH Stepper motor with free wire ends

¹⁾Required space for terminal box cover fixing screws: up to 2 mm

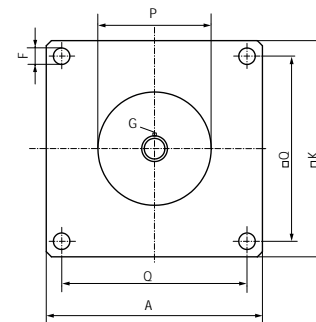

Standard flange

Stepper motor	Dimensions									Key			Flange and shaft:				Flange and shaft:			
	A	± 0.5 B1	±0.5 B2	C1	C2	D	E	F	±0.5 K	G	H	H'	-0.02 M	-0.02 N	-0.05 P	Q	-0.02 M	-0.02 N	-0.05 P	Q
	mm									mm			mm				mm (inch)			
ZSH 57/1	56.5	50	76	90	108	1.5	5	5.3	21	1)							6.35	6.35	38.1	47
ZSH 57/2	56.5	76	102	116	134	1.5	5	5.3	21		12	12	73	70	9.52	9.52	73	70		
ZSH 57/3	56.5	104	130	144	162	1.5	5	5.3	21		12	12	73	70	9.52	9.52	73	70		
ZSH 87/1	86	60.5	85.5	137	137	1.5	5.7	6.5	31.5	up to Ø10: A3x3x15	6	1.5	12	12	73	70	9.52 (0.375)	9.52 (0.375)	73 (2.87)	70 (2.76)
ZSH 87/2	86	92.5	117.5	169	169	1.5	5.7	6.5	31.5	from Ø12: A4x4x15										
ZSH 87/3	86	124.5	149.5	201	201	1.5	5.7	6.5	31.5	from Ø12: A4x4x15										
ZSH 88/1	86	68.5	93.5	145	145	1.5	5.7	6.5	31.5	up to Ø10: A3x3x15	6	1.5	12	12	73	70	9.52 (0.375)	9.52 (0.375)	73 (2.87)	70 (2.76)
ZSH 88/2	86	100.5	125.5	177	177	1.5	5.7	6.5	31.5	from Ø12: A4x4x15										
ZSH 88/3	86	132.5	157.5	209	209	1.5	5.7	6.5	31.5	from Ø12: A4x4x15										
ZSH 107/1	108	89.5	111	-	170	1.5	9	8.5	32	A5x5x20	5	5	12	10	60	90	12.7 (0.5)	12.7 (0.5)	55.54 (2.186)	88.9 (3.5)
ZSH 107/2	108	139.5	161	-	238	1.5	9	8.5	50											
ZSH 107/3	108	189.5	211	-	288	1.5	9	8.5	50											
ZSH 107/4	108	239.5	261	-	338	1.5	9	8.5	50											

blue = standard version

¹⁾ Optional for size 57: Woodruff key 2x2.6 DIN 6888

Mechanical and Electrical Characteristics ZSH 57 to ZSH 107

Stepper motor type	Phase current bipolar ^{2a)}	Phase current unipolar ^{2a)}	Resistance per winding ^{3a)}	Inductivity per winding ^{2a)}	Holding torque ¹⁾	Detent torque	Rotor mass inertia	Permissible bearing load		Mass
								axial	radial	
	A	A	Ω	mH	Nm	Nm	10 ⁻⁴ kg m ²	N	N	kg
ZSH 57/1	1.4 / 4.2 / 5.5	1 / 3 / 3.9	5.5 / 0.7 / 0.5	9 / 1 / 0.64	0.45	0.01	0.125	80	150	0.6
ZSH 57/2	2.1 / 2.8 / 4.2	1.5 / 2 / 3	4.1 / 2.6 / 1.1	9 / 5 / 2.6	0.85	0.017	0.25	80	150	1
ZSH 57/3	2.1 / 4.2 / 6.5	1.5 / 3 / 4.6	4.3 / 1.6 / 0.8	9 / 3 / 1.2	1.25	0.025	0.375	80	150	1.35
ZSH 87/1	2.3 / 4.2 / 7	1.6 / 3 / 5	3 / 0.8 / 0.3	6 / 1.6 / 0.7	1.8	0.026	0.65	180	280	1.7
ZSH 87/2	5 / 6.5 / 8.4	3.5 / 4.6 / 6	0.8 / 0.5 / 0.3	3 / 1.5 / 1	3.6	0.05	1.3	180	280	2.65
ZSH 87/3	5 / 8.4 / 10	3.5 / 6 / 7	1.1 / 0.5 / 0.4	5 / 1.7 / 1	5.4	0.08	1.95	180	280	3.65
ZSH 88/1 ¹⁾	2 / 4 / 8	-	1.88 / 0.5 / 0.13	11.1 / 2.5 / 0.75	3	0.042	1.35	180	280	1.7
ZSH 88/2	2 / 4 / 8	-	3.61 / 0.74 / 0.21	26 / 5.5 / 1.5	6	0.08	2.7	180	280	2.65
ZSS 88/3	4 / 8 / 12	-	1.14 / 0.29 / 0.14	10.9 / 2.6 / 1	9	0.13	4.05	180	280	3.65
ZSH 107/1	7 / 8 / 12.5	5 / 5.7 / 8.8	0.3 / 0.2 / 0.1	1.6 / 1.2 / 0.55	5	0.11	4	400	650	4.3
ZSH 107/2	8 / 10 / 12.5	5.7 / 7.1 / 8.8	0.4 / 0.3 / 0.2	2.4 / 1.6 / 1.15	9	0.21	8	400	650	7.2
ZSH 107/3	10 / 12.5	7.1 / 8.8 / -	0.4 / 0.3	2.7 / 1.9 / -	13	0.3	12	400	650	9.8
ZSH 107/4	12.5	8.8	0.4	2.7	17	0.4	16	400	650	12.5

blue=popular types¹⁾ Size 88 for bipolar operation only²⁾ Standardwicklung 1/2/3³⁾ The current value given in the ordering data (e. g. ZSH 107/2.200.8) refers to the bipolar mode (parallel windings).⁴⁾ Current in unipolar mode = 0.7 x current in bipolar mode⁵⁾ Resistance per phase in bipolar mode = 0.5 x resistance per winding⁶⁾ The inductivity values apply for each single winding as well as for two parallel windings.
For series mounted windings, the inductivity is multiplied by 4.

Elektrischer Anschluss / Schaltungsarten / Phase current

The phytron stepper motors type ZSH are built in 4-lead parallel windings (standard).

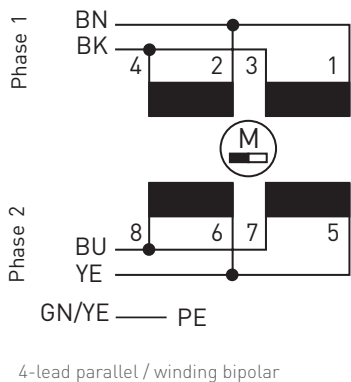

Terminal Box

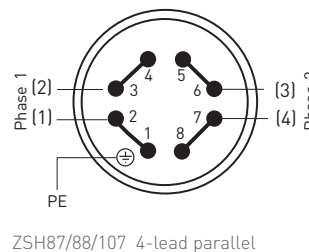
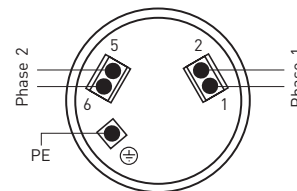

Alternative windings like 8-lead are available on request:

The motors can be used with unipolar or bipolar control mode, as the windings can be differently connected.

5-lead connection is applicable for the unipolar control mode.

In the bipolar control mode, 4-lead motor wiring is required, windings connected in parallel or in series.

The information in the ZSS motor connection leaflet (delivered with each motor) must be regarded when wiring the motor in order to provide for EMC compliant wiring. The motor connection leaflets are also available by down-load from the phytron homepage.

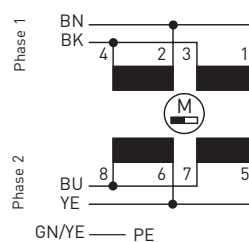
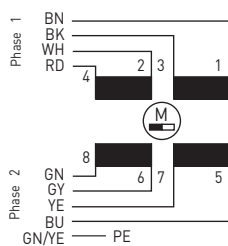
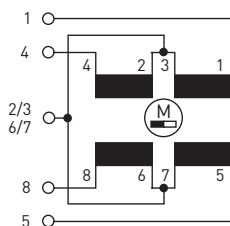
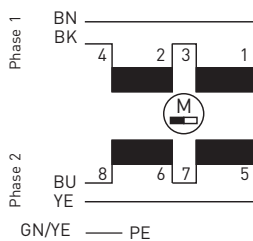
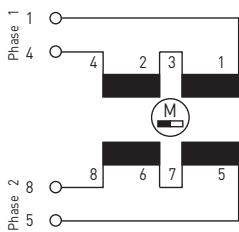

Dimensions ZSH Stepper Motor with Brake / Encoder

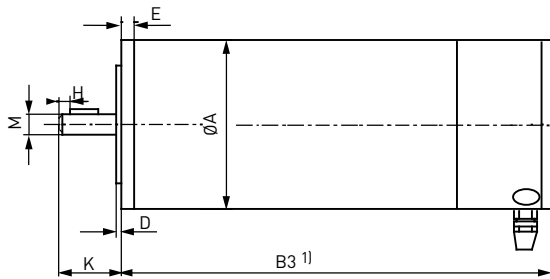

Optional: ZSH Stepper motor with brake

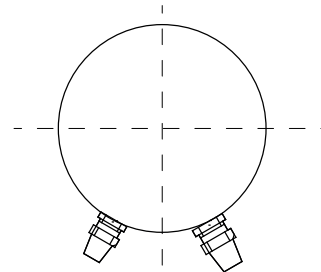

Rear view: Motor with brake/encoder

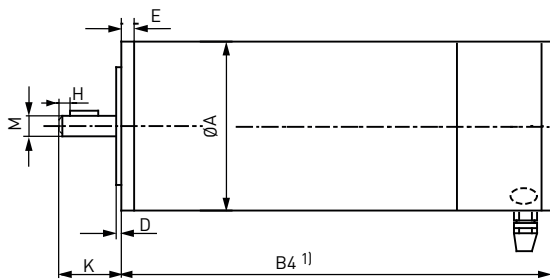

Optional: ZSH Stepper motor with encoder

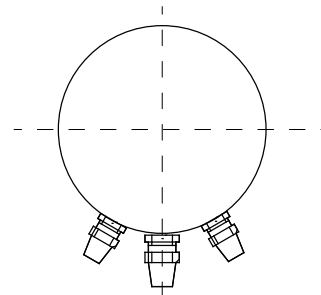

Rear view: Motor with encoder and brake

¹⁾Required space for terminal box cover fixing screws: up to 2 mm

Dimensions Stepper Motor / Brake / Encoder

Stepper motor	Ø Motor	ZSH + KEB	ZSH + E50	ZSH + H200/500	ZSH + KEB + E50	ZSH + KEB + H200/500	C1	C2	D	E	F	K
	A	B3	B4	B5	B6	B7						
ZSH 57/1	56.5	116	88	98	128	137.5	90	108	1.5	5	5.3	21
ZSH 57/2	56.5	142	114	124	154	163.5	116	134	1.5	5	5.3	21
ZSH 57/3	56.5	170	142	152	182	191.5	144	162	1.5	5	5.3	21
ZSH 87/1	86	131	85.5	104	131	153	137	137	1.5	5.7	6.5	31.5
ZSH 87/2	86	163	117.5	136	163	185	169	169	1.5	5.7	6.5	31.5
ZSH 87/3	86	195	149.5	168	195	217	201	201	1.5	5.7	6.5	31.5
ZSH 88/1	86	139	93.5	112	139	161	145	145	1.5	5.7	6.5	31.5
ZSH 88/2	86	171	125.5	144	171	193	177	177	1.5	5.7	6.5	31.5
ZSH 88/3	86	203	157.5	176	203	225	209	209	1.5	5.7	6.5	31.5
ZSH 107/1	108	161	111	136	161	193	-	170	1.5	9	8.5	32
ZSH 107/2	108	211	161	186	211	243	-	238	1.5	9	8.5	50
ZSH 107/3	108	261	211	236	261	293	-	288	1.5	9	8.5	50
ZSH 107/4	108	311	261	286	311	343	-	338	1.5	9	8.5	50

Dimensions in mm

Metric Cable Glands

Dimensions in mm	Cable Ø	Wrench size
Stepper motor connection	9-13	22
Encoder connection	5-9	17
Motor brake connection	5-9	17

- For shielded cables
- Material: nickel plated brass
- Protection class: IP 68 up to 5 bar
- Nitril rubber sealing rings
- Nitril rubber O-ring on external thread
- Test standard EN 50262 / UL 514B

Dimensions in mm

ZSH Stepper motor with integrated encoder

In non disturbed operation the stepper motor runs synchronously to the pulses coming from the controller, that means the motor rotation (= rotation of the rotor) runs synchronously to the pulse frequency (= rotating stator field in the motor). In case of an extreme load at the motor (e.g. via a static load at the motor shaft or by accelerating of the motor) the step frequency of the motor will shortly differ from the pulse frequency within a certain maximum range. This results in changing the load angle (= difference between the real position of the rotor and its target position). For applications homing mode for monitoring the motor movement, we recommend to use a motor with an integrated encoder.

ZSH Stepper motor with integrated encoder E50



The encoder series E50 monitors the motion of the motor. Together with a phytron controller (e.g. MCC- or *phyMOTION*[®] series) the load angle of the stepper motor can be controlled and monitored. When the max. admissible load angle is exceeded (e.g. when the motor run is breaking down) the control unit will create an error signal.

Special Characteristics

- Simple and robust low cost version
- no changes of the motor dimensions in comparison to the standard version with cast connection box (except ZSH 56)
- the encoder is integrated in the motor housing
- available up to protection class IP68
- all requirements for mechanical and climatical ambient conditions (vibration-, shock resistance, temperature and humidity) are fulfilled.
- evaluation of the encoder signals and realisation of a step angle control with generating an error signal can be done by using a phytron controller of the MCC or *phyMOTION*[®] series.

Electrical Characteristics

Supply voltage	5 to 24 V _{DC}
Current consumption	typ. approx. 35 mA (no load at outputs) max. load at outputs 100 mA / output
Operating temperature	-40 to 125 °C

Outputs

2 x 50 pulses per revolution – signals A and B with rectangular shape and inverted signals \bar{A} and \bar{B}

duty cycle 1:1 ± max. 20 % error

bipolar – switching to VCC and GND

short circuit protected signals against GND

RS422 line driver [26LS31]

pulse frequency min. 20 kHz

Signal outputs

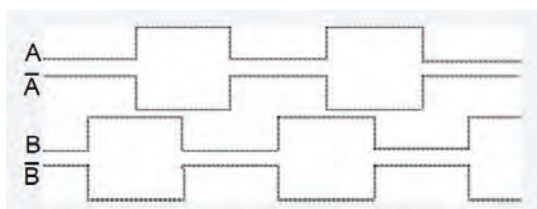

Connection

connection via screw terminals for nominal cross section max. 1mm² [26 -16 AWG]

optionally also available with connector

dimensions as standard motor types! - exception: ZSH 56: see table page 5

ZSH Stepper motor with integrated encoder H200 and H500



The H200 and H500 is characterized by its high resolution; H200 with 2x200 pulse per revolution and the H500 with 2x500 pulse per revolution. It fulfills as an extremely robust encoder also the high requirements for mechanical and climatic environmental conditions (vibration, shock, shock resistance, temperature and humidity).

Special Characteristics

- optical encoder
- the encoder is integrated in the motor housing.
- available up to protection class IP68
- all requirements for mechanical and climatic ambient conditions (vibration-, shock resistance, temperature and humidity) are fulfilled
- evaluation of the encoder signals and realisation of a step angle control with generation of an error signal can be done by using a phytron controller of the MCC or *phyMOTION*® series

Technical Characteristics

Optical encoder	
Supply voltage	5 V _{DC}
Operating temperature	-40 to 100 °C

Outputs

2 x 200 pulse per revolution for H200
2 x 500 pulse per revolution for H500
rectangular shape signals A and B, with inverted signals \bar{A} and \bar{B}
H200 and H500: zero pulse and inverted zero pulse - 1 pulse per revolution
duty cycle 1:1 +max. 10 % error
RS422 line driver (26LS31)
short circuit protected signals against GND
pulse frequency min. 100 kHz

Signal outputs

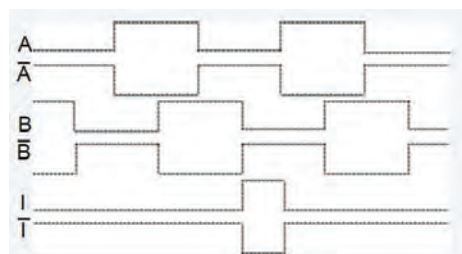

Dimensions

the modified dimensions – compared to the standard motors ZSH without encoder – can be found in the table on page 5.

Connection

connection via screw terminals for nominal cross section max. 1 mm ² (26 - 16 AWG)
optionally also available with connector

Harsh

Stepper Motor ZSH 57 / 87 / 88 / 107 with PLE Planetary Gear

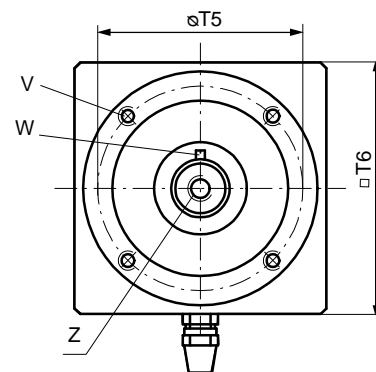
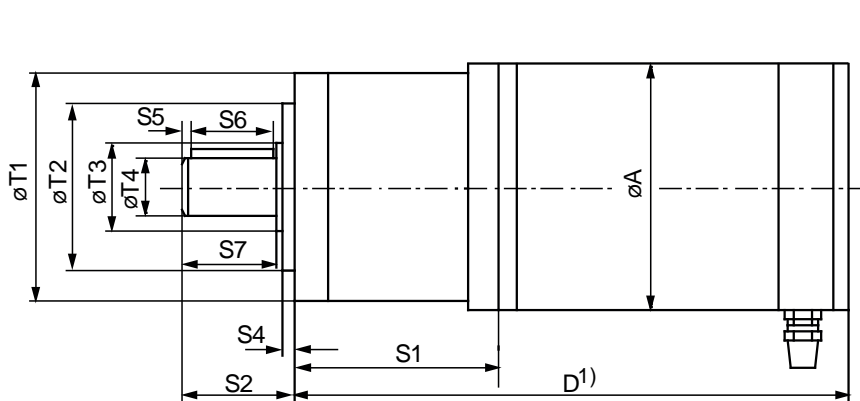

1) Required space for terminal box cover fixing screws: up to 2 mm

W: Key DIN 6885 T1, type A
Z: Centering bore DIN 332, type DS

Dimensions Stepper Motor with Gear

Gear	Stages	Dimensions in mm																				
		A	Total length gear/motor with terminal box				S1	S2	S4	S5	S6	S7	T1	T2	T3	T4	T5	T6	V	W	Z	
PLE 60	1	56.5	ZSH 57/1	ZSH 57/2	ZSH 57/3		55		3	2.5	25	30	60	40	17	14	52	60	M5 x 8	5 x 5 x 25	M5 x 12	
	2		143	169	197		67															35
	3		156	182	210		80															
PLE 80	1	86	ZSH 87/1	ZSH 87/2	ZSH 87/3	106.5	72	40	3	4	28	36	80	60	25	20	70	86	M6 x 10	6 x 6 x 28	M6 x 16	
	2		157.5	189.5	221.5		89															
	3		174.5	206.5	238.5		106.5															
	1		ZSH 88/1	ZSH 88/2	ZSH 88/3	106.5	72															
			2	165.5	197.5		229.5															89
			3	182.5	214.5		246.5															106.5
PLE 120	1	108	ZSH 107/1	ZSH 107/2	ZSH 107/3	ZSH 107/4	185.5	55	4	5	40	50	115	80	35	25	100	115	M10 x 16	8 x 7 x 40	M10 x 22	
	2		242.5	292.5	342.5	392.5																131.5
	2		269.5	319.5	369.5	419.5																158.5
	3		296.5	346.5	396.5	446.5																185.5

Motor/Gear Output Torque

The output torque of the motor/gear combination can be calculated as follows: Motor torque at the required speed (see frequency characteristics) multiplied with reduction ratio and gear efficiency.

Mechanical Characteristics: Motor with PLE				
Gear	Stages	Reduction Ratio	Permissible gear output torque	Mass inertia (without motor) ¹⁾
			Nm	10 ⁻⁴ kg m ²
			ZSH 57	
PLE 60	1	3:1	28	6.5
		4:1	38	3.3
		5:1	40	2.2
		8:1	18	1.2
	2	9:1	44	7.2
		12:1	44	7
		15:1	44	2.4
		16:1	44	3.4
		20:1	44	2.4
		25:1	40	2.3
		32:1	44	1.2
		40:1	40	1.2
3	64:1	18	1	
	60:1	44	2.4	
	80:1	44	2.4	
	100:1	44	2.4	
	120:1	44	1.2	
	160:1	44	0.1	
	200:1	40	0.1	
	256:1	44	0.1	
320:1	40	0.1		
512:1	18	0.1		
			ZSH 87	
PLE 80	1	3:1	85	63
		4:1	115	25
		5:1	110	14
		8:1	50	8
	2	9:1	130	63
		12:1	120	26
		15:1	110	62
		16:1	120	25
		20:1	120	15
		25:1	110	15
		32:1	120	8
		40:1	110	8
3	64:1	50	6	
	60:1	110	25	
	80:1	120	18	
	100:1	120	15	
	120:1	110	60	
	160:1	120	8	
	200:1	110	8	
	256:1	120	8	
320:1	110	6		
512:1	50	6		
			ZSH 107	
PLE 120	1	3:1	115	2.6
		4:1	155	1.79
		5:1	195	1.63
		8:1	120	1.32
	2	9:1	210	2.62
		12:1	260	2.56
		15:1	230	2.53
		16:1	260	1.75
		20:1	260	1.5
		25:1	230	1.49
		32:1	260	1.3
		40:1	230	1.3
3	64:1	120	1.3	
	60:1	260	2.57	
	80:1	260	1.5	
	100:1	260	1.5	
	120:1	230	2.5	
	160:1	260	1.3	
	200:1	230	1.3	
	256:1	260	1.3	
320:1	230	1.3		
512:1	120	1.3		

blue=popular type ¹⁾ Mass inertia referred to motor shaft

PLE Planetary Gear							
Gear	Stages	Torsional stiffness	Absolute backlash	Efficiency	Mass without motor	Maximum axial load ²⁾	Maximum radial load ²⁾
		Nm/arcmin	angular minutes	% (approx.)	kg	N	N
PLE 60	1	2.3	<20	96	0.65		
	2	2.5	<25	94	0.82	600	500
	3	2.5	<30	90	1		
PLE 80	1	6	<12	96	1.6		
	2	6.5	<17	94	2.2	1200	950
	3	6.3	<22	90	2.8		
PLE 120	1	12	<8	96	6.5		
	2	13	<12	94	9	2800	2000
	3	12	<16	90	11.5		

²⁾ referred to center of output shaft

PLE Planetary Gear

- Low-backlash / high efficiency
- Torque shaft bearing: ball bearing
- Lifetime lubrication
- Recommended operation temperature range: -25 to +90 °C
- Mounting position: any
- Standard protection class: IP 54
- Optional: protection class: IP 65
- These gears are specially sealed. Output shaft and keyway are made of stainless steel.
- Angled gears on request

Harsh

Frequency Characteristics

The curves correspond to the limit values of the operational characteristics (T) as a function of the control pulses (frequency/speed), for two different supply voltages (U). The motor connection type is 4-leads with parallel windings. The motors are controlled by phytron stepper motor power stages in the half-step mode.

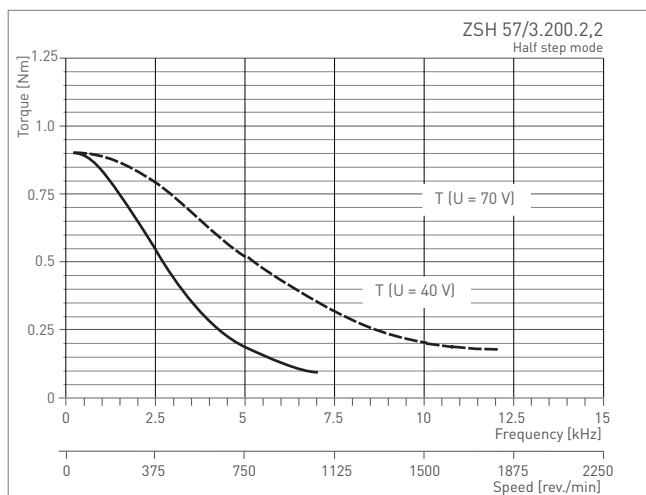
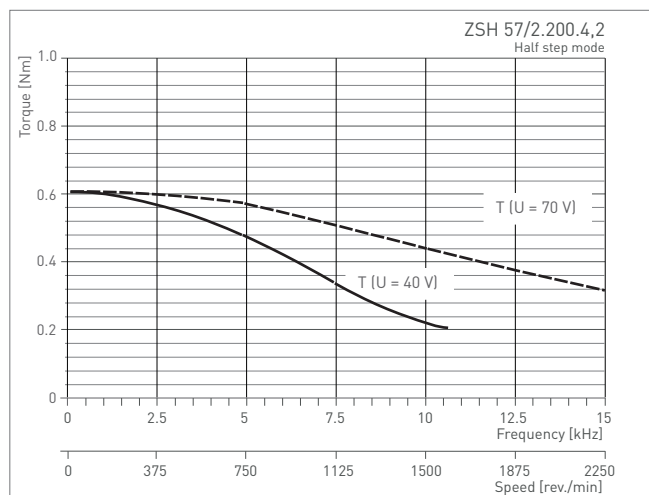
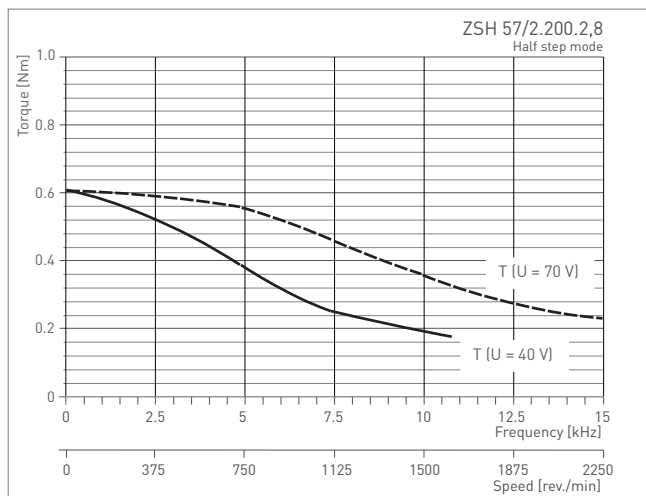
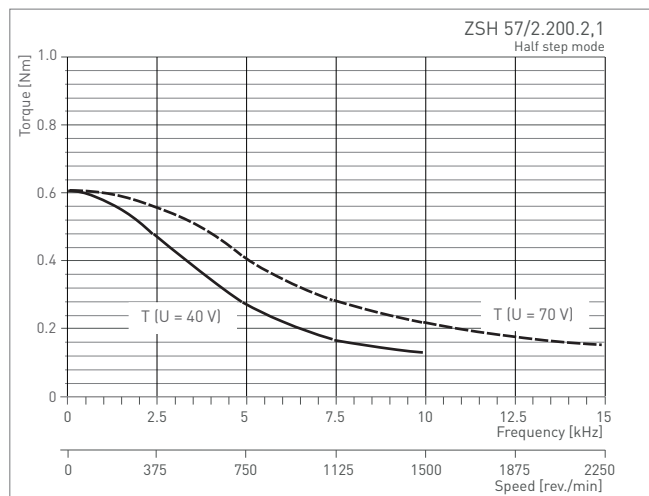
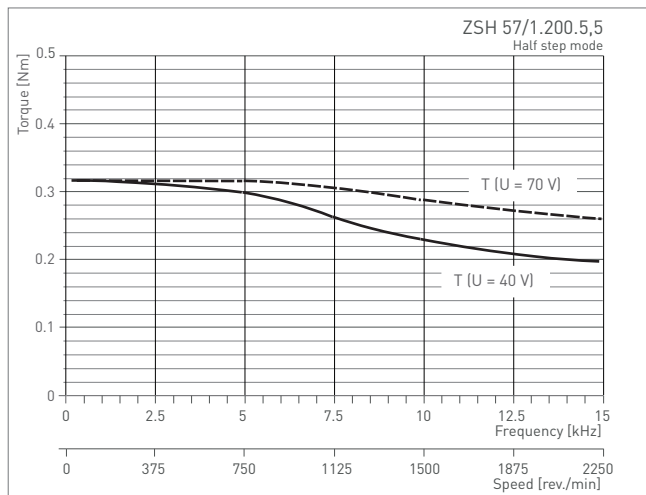
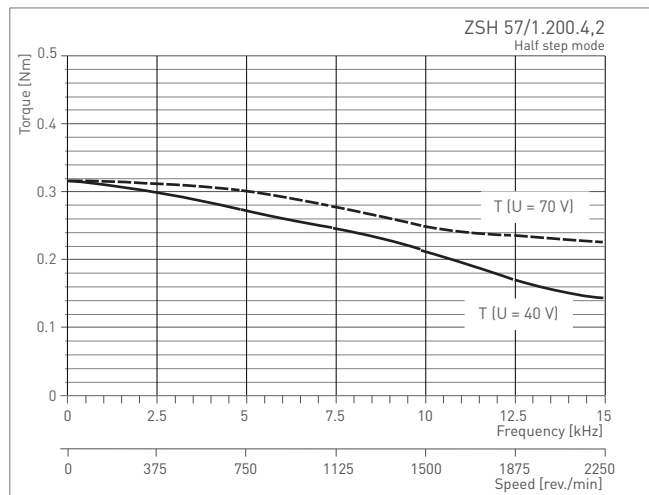

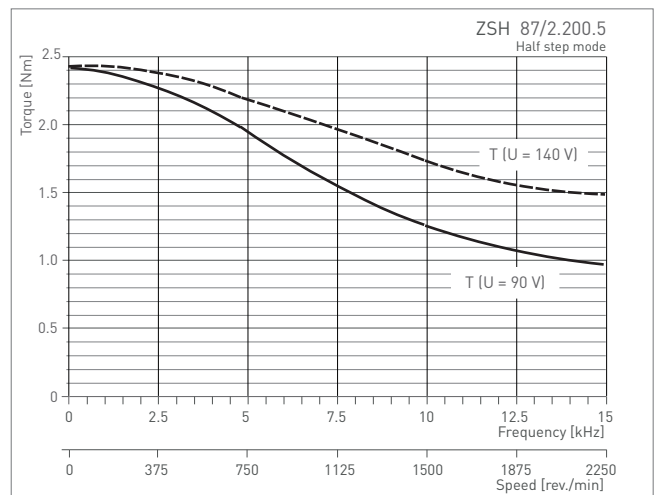
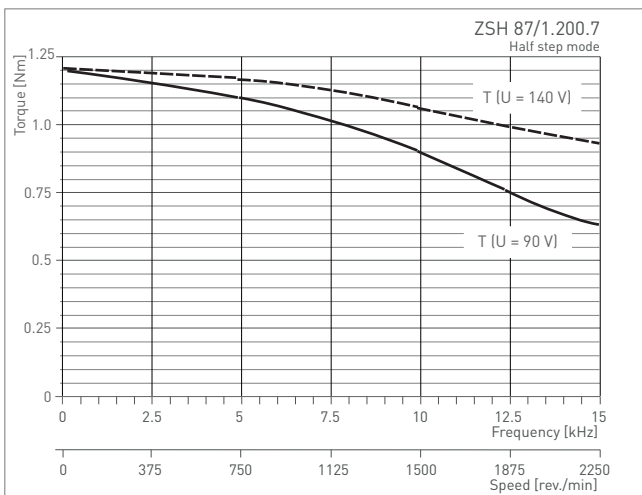
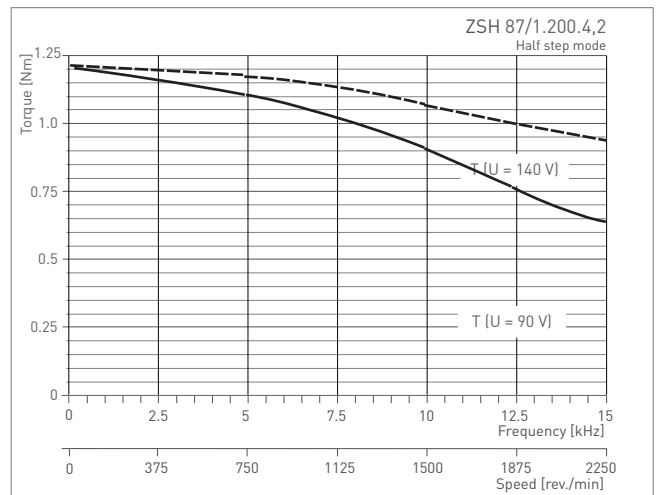
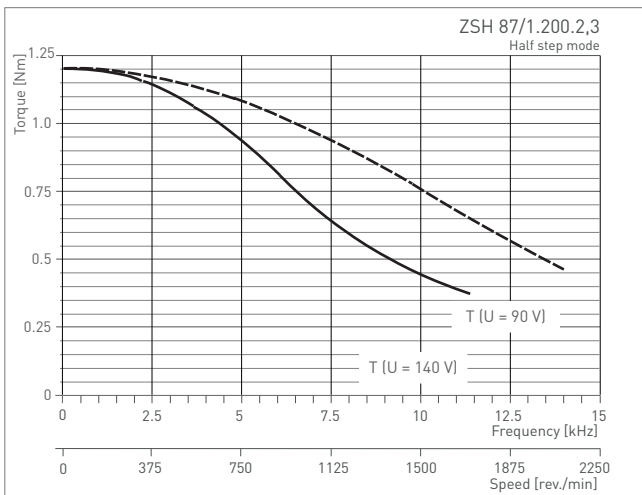
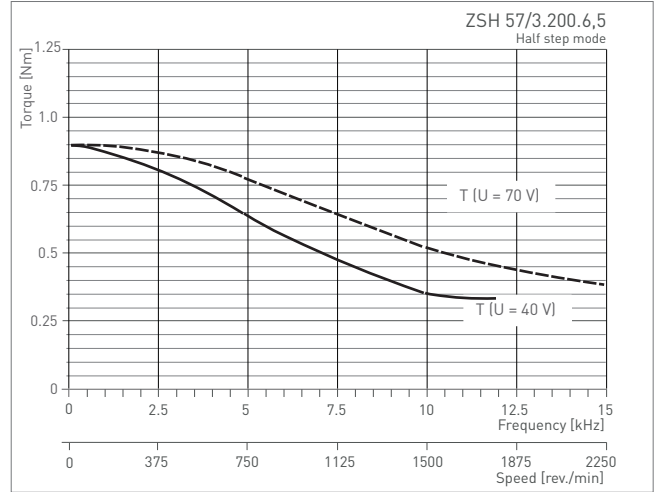
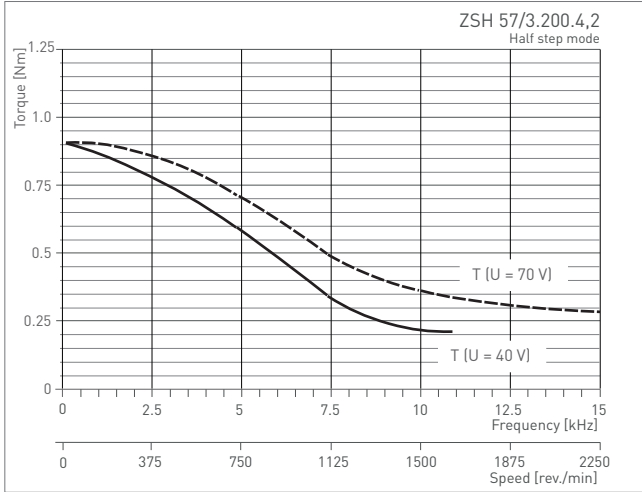

Harsh

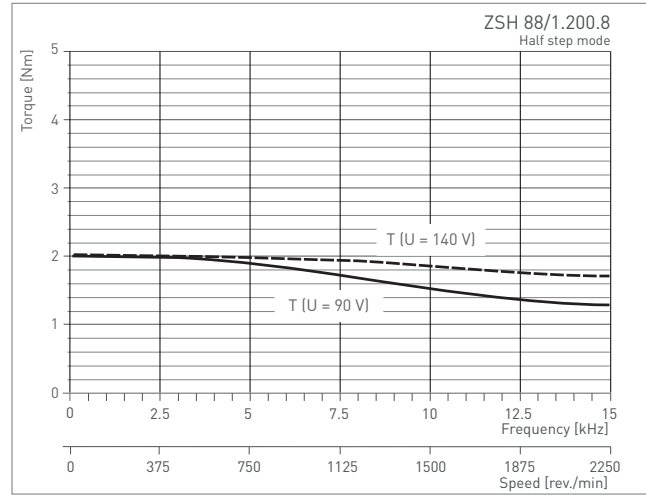
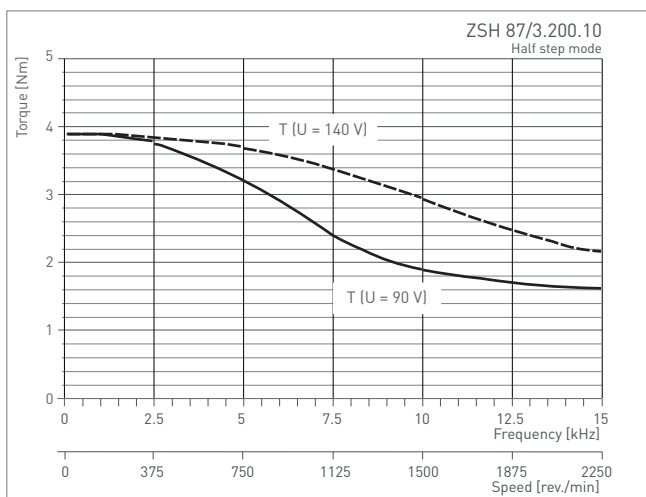
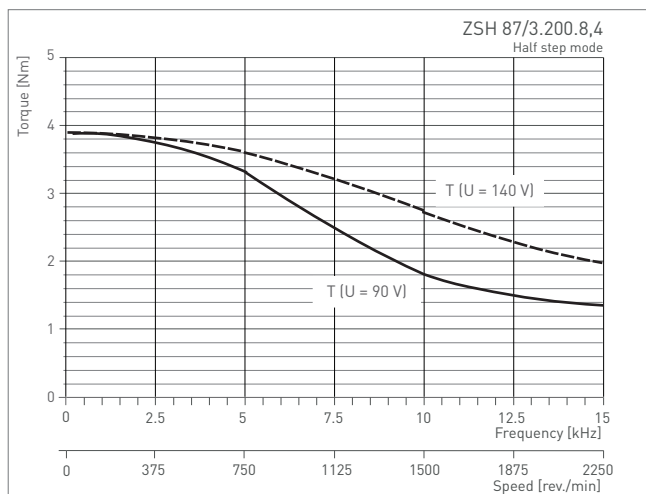
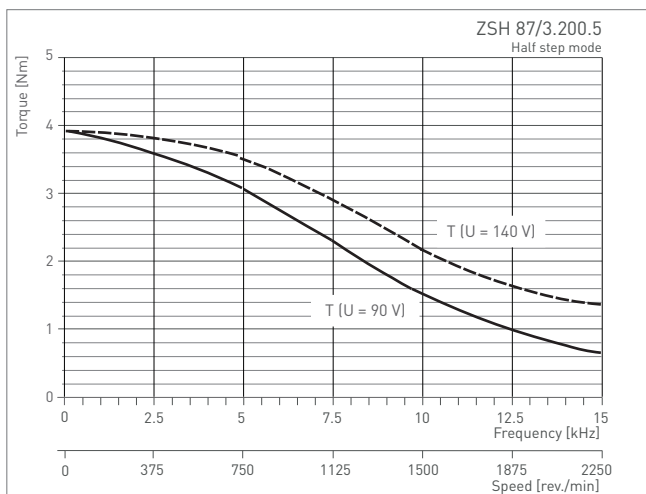
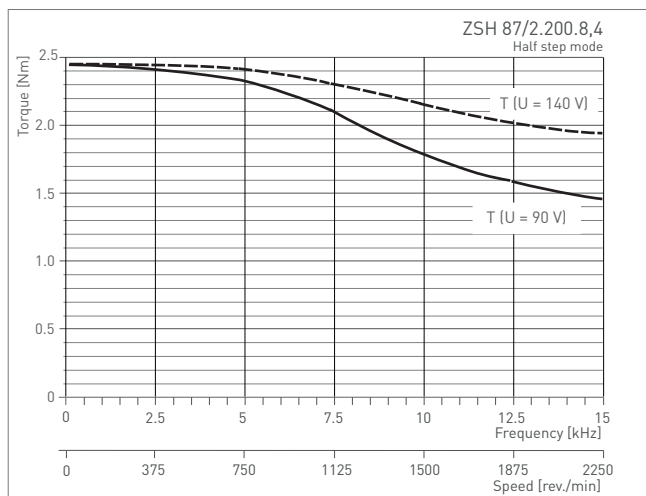
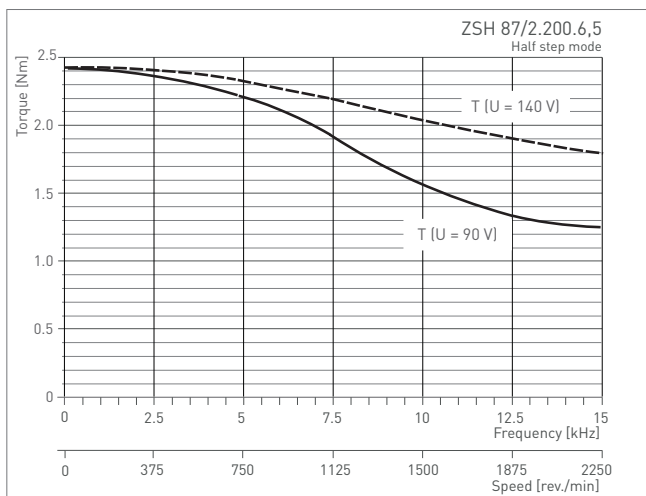

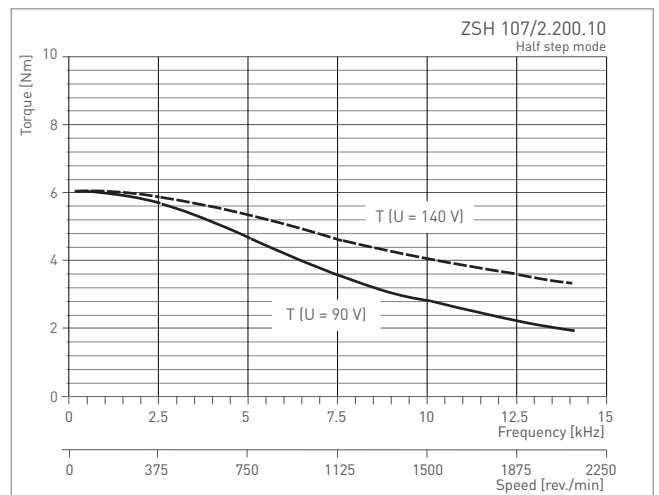
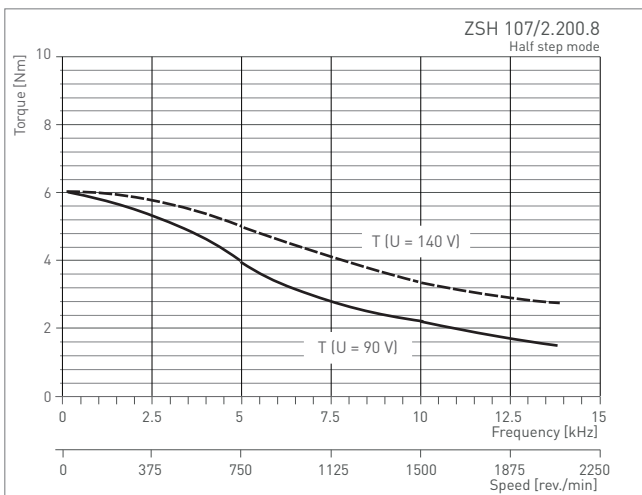
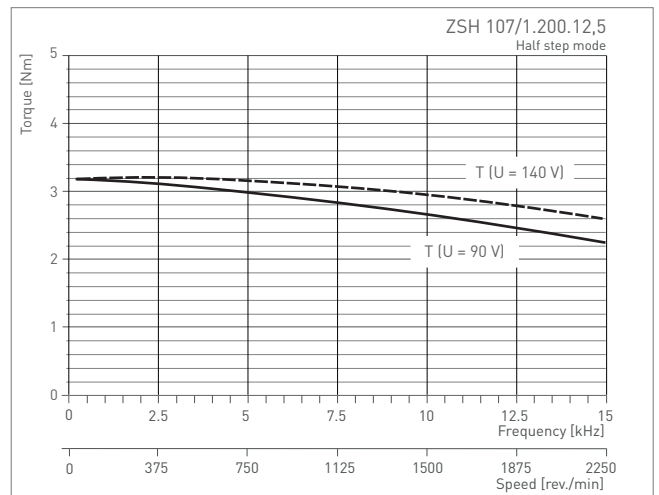
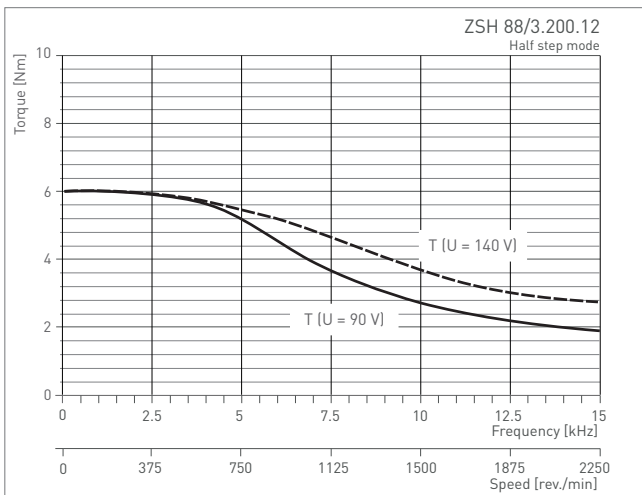
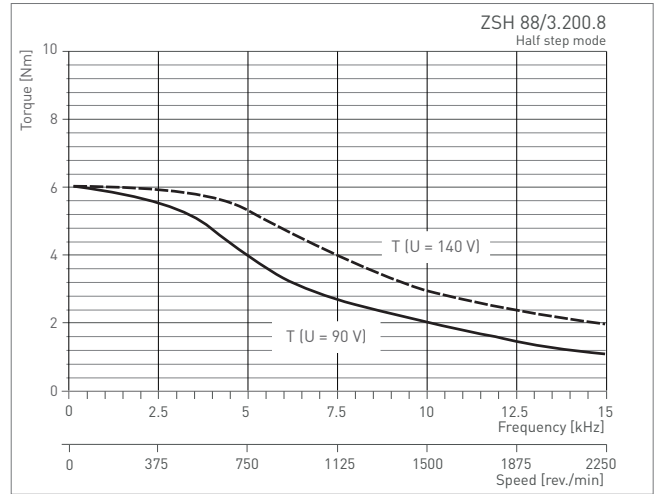
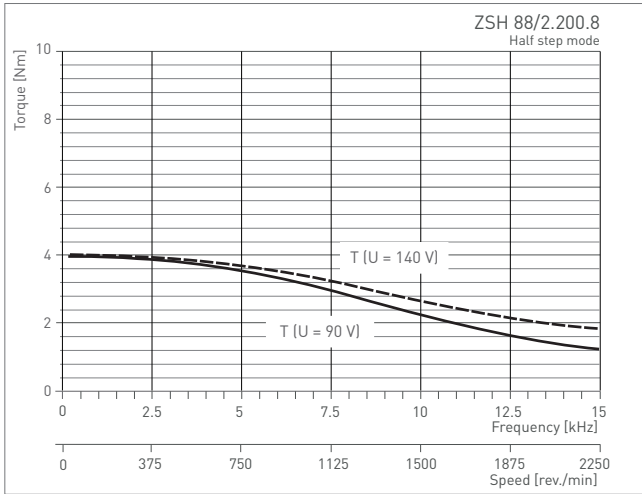

Harsh

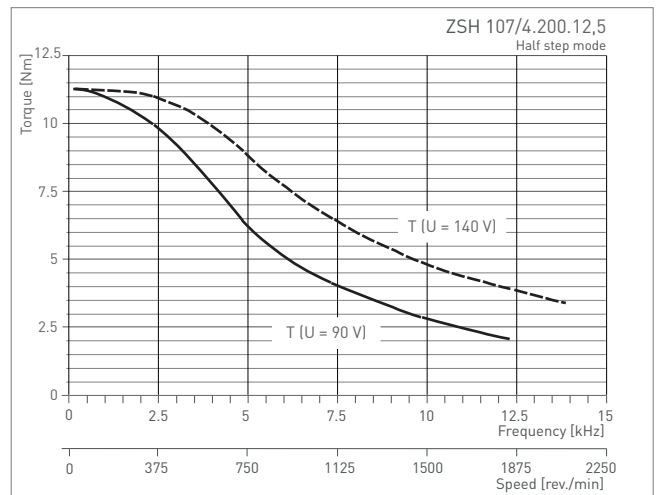
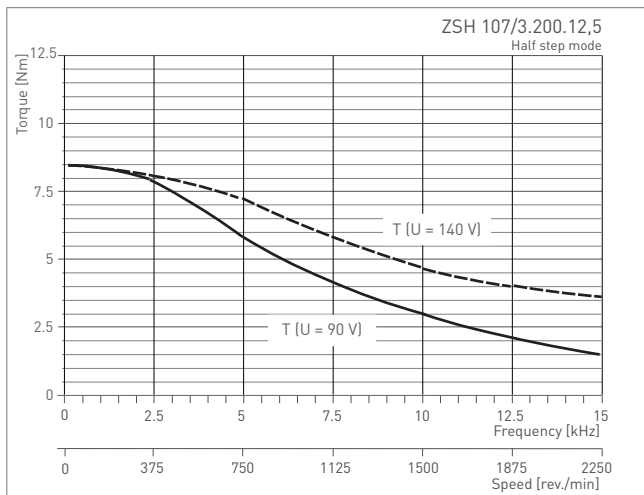
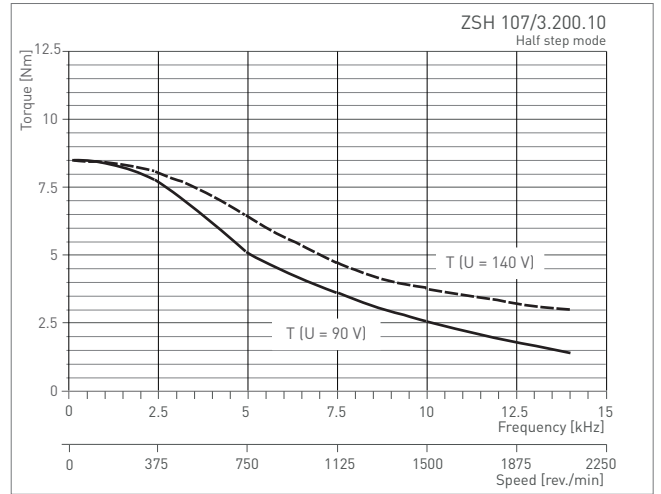
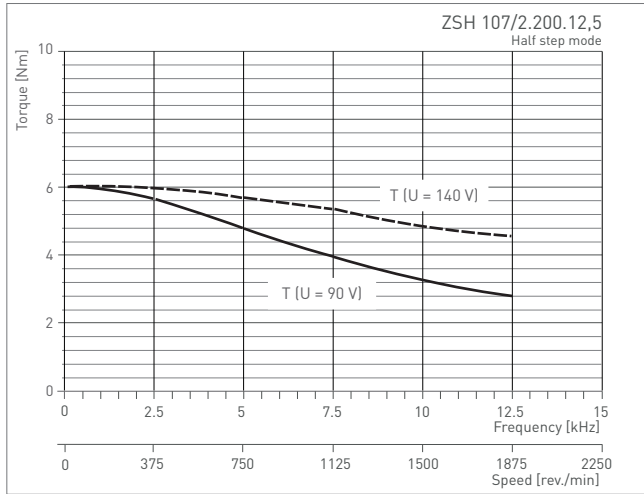

Harsh

Ordering Code

Ordering Code	Type	Edge dimension	Length	Number of steps	Nominal current	Option	Gear	Reduction ratio	Protection class	Connection of the windings
ZSH	87	3	200	10	H200	PLE	12:1	IP68	4s	

Options	
Edge dimension	57 / 87 / 88 / 107
Length	1 / 2 / 3 / 4
Nominal current	available windings see page
Option	∅ Shaft/Flange (not specified = standard design)
2nd shaft	E
Free wire ends	FD
Motor brake	B
Encoder	E50 / H200 / H500
Encoder and motor brake	E50-B / H200-B / H500-B
Gear	PLE
Reduction ratio	see page 7
Protection class	not specified = standard protection class IP 54 IP 68
Connection of the windings	not specified = standard wiring scheme: 4-lead/parallel windings
4-lead/serial windings	4s
5-lead	5
8-lead	8

A motor connection leaflet is enclosed to every delivery of stepper motors. PDF files are available for download from the phytron homepage.

All illustrations, descriptions and technical specifications are subject to modifications; no responsibility is accepted for the accuracy of this information.

Phytron GmbH

Industriestraße 12 – 82194 Gröbenzell
 T +49-8142-503-0 F +49-8142-503-190