

## alpha Value Line - NPR Sizing and Technical Data

Efficient  
Flexible  
Reliable

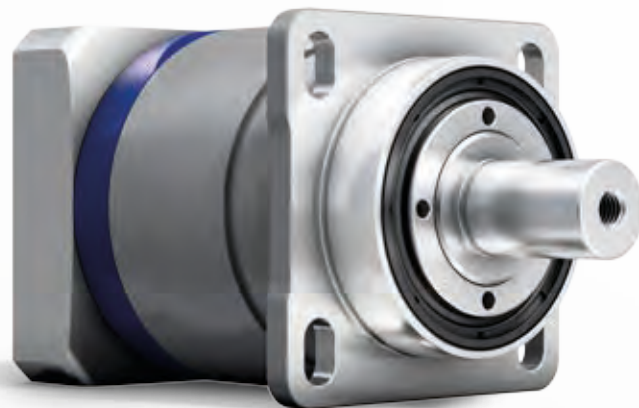



alpha Value Line	NP	NPS	NPL	NPT	NPR	
<b>Ratios</b>	3-100					
Torsional backlash [arcmin]	≤ 8					
<b>Output type</b>						
Smooth output shaft	•	•	•	–	•	
Grooved output shaft	•	•	•	–	•	
Output shaft with involute toothing	–	•	•	–	•	
Output flange	–	–	–	•	–	
<b>Input type</b>	<b>Motor attachment version</b>					
<b>Application</b>						
For high axial and radial forces	–	•	•	–	•	
In continuous operation	•	•	•	•	–	
In cyclic operation	•	•	•	•	•	
<b>Options</b>						
HIGH TORQUE version	•	•	•	•	•	
Foodgrade lubrication	•	•	•	•	•	
With coupling at output	•	•	•	•	•	
As linear system	•	•	•	–	•	
With mounted pinion at output	•	•	•	–	•	
With screwed on B5 flange	•	–	–	–	–	
<b>Further technical data</b>						
Max. torque $T_{2a}$	Nm	800	800	800	800	800
	in.lb	7100	7100	7100	7100	7100
Max. input speed	rpm	10000	8000	8000	10000	8000
Efficiency	%	97%	97%	97%	97%	97%
Max. radial force $F_{2R}$	N	8000	9900	9900	4800	9900
	lb <sub>r</sub>	1800	2200	2200	1080	2200

# WITTENSTEIN alpha adapted for any axis

The perfect drive solution whatever  
the requirements are

WITTENSTEIN alpha develops complete, single-supplier solutions for driving any axis. They can be used in virtually any application – from high-precision axes in machine tools and manufacturing systems to packaging machinery where maximum productivity is a must.

The name WITTENSTEIN alpha is synonymous with premium quality and optimal reliability, high precision and synchronization accuracy, maximum power density, a long lifetime and very simple motor mounting.

The alpha Value Line is a new product family that unites these characteristics – which are specially adapted for applications in the value segment or high-end secondary axes – in a class-appropriate way.

## Benefits of the alpha Value Line:

- Rapid availability regardless of the batch size
- Optimal flexibility
- Ability to react promptly to changing customer requirements
- Assembly to order

## Contents

Sizing of the alpha Value Line – NPR	4
NPR 015S	6
NPR 025S	8
NPR 035S	10
NPR 045S	12
Glossary	14
Order codes	15

# alpha Value Line

## Efficient sizing

### The new sizing method

The new alpha Value Line from WITTENSTEIN alpha commits the cymex® sizing software to paper. Using a quick select structure, you can define your drive train in just a few simple steps.

- Quick and easy gearhead selection based on your application.
- Maximum transmissible torque  $T_{2a}$  as the starting point for selecting the gearhead (definition  $T_{2a} \neq T_{2B}$ ).  
No restriction on  $T_{2a}$  due to a maximum number of cycles per hour.
- Optional: Quick selection based on the maximum motor torque.

#### Your application

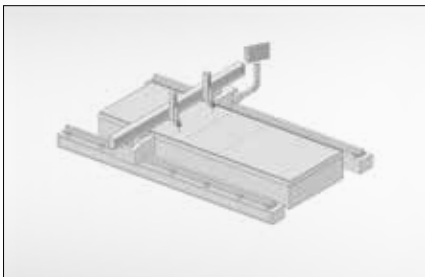

#### Determine application torque

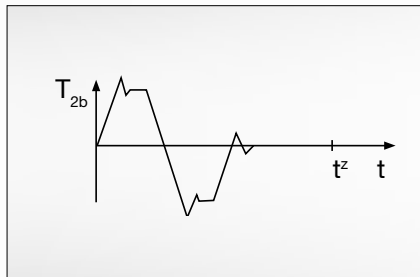

#### Define system utilization

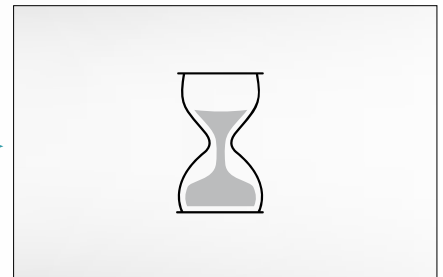

#### Calculate equivalent application torque

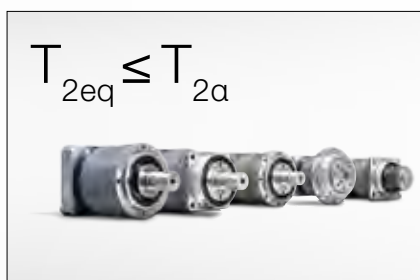

#### Select gearhead

### Your Benefits:

- Perfect-fit sizing of your drive
- Efficient and reliable gearhead selection
- Huge time saving
- Computational work for simple applications reduced to a minimum\*
- Consideration of radial and axial forces if necessary

\*We recommend our cymex® sizing software for complex applications

# Sizing of the alpha Value Line – NPR

**A:** Simplified sizing for servo motors based on the maximum motor torque:  $M_{max} * i \leq T_{2\alpha}$

**B:** Sizing based on the application

## Step 1:

Determine the maximum application torque:  $T_{2b} = \text{_____} \text{ [Nm]}$

## Step 2:

Determine the operating mode factor  $K_M = \text{_____}$

Typical applications	Cycle	Torque characteristic	Operating mode factor $K_M$
Format changing, e.g. in packaging machines, drives for processing equipment, actuators, etc.	<b>S5 operation:</b> Low duty cycle Small number of cycles Low dynamics		1,0
Tool changers with low dynamics, pick & place gantry axes, tire building machines, etc.	<b>S5 operation:</b> Medium duty cycle Small number of cycles Medium dynamics		1,6
Linear modules, linear axes in woodworking machines, ball screw drives, etc.	<b>S5 operation:</b> Medium duty cycle Medium number of cycles Medium dynamics		1,9
Roller drives in printing presses, star drives in rackers, etc.	<b>S1 operation:</b> High duty cycle		2,2
Linear axes in plasma, laser or water jet cutters, portals, tool changers with high dynamics	<b>S5 operation:</b> Medium duty cycle Medium number of cycles High dynamics		2,5
SCARA robots, gantry robots, machining spindles, etc.	<b>S5 operation:</b> High duty cycle High number of cycles High dynamics		3,0

## Step 3:

Determine the sizing factor with the operating mode factor  $K_M$   $f_a = \text{_____}$

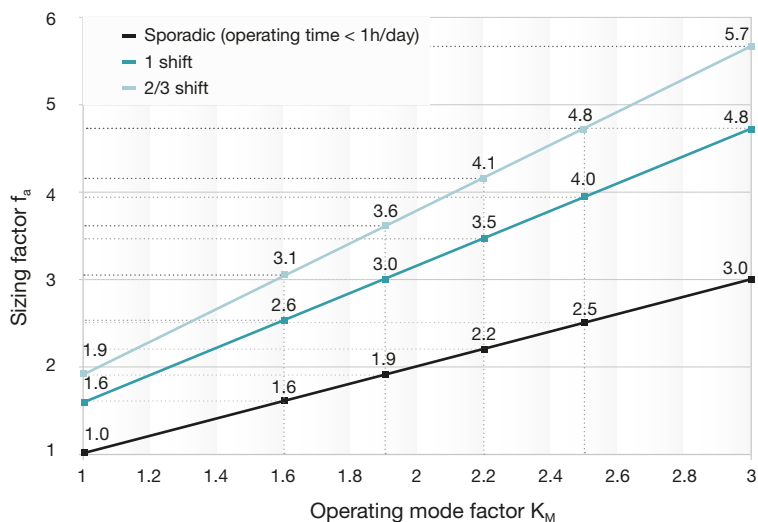

## Step 4:

Compare the equivalent application torque with the maximum gearhead  $T_{2\alpha}$  (see table, Step 5)

$$T_{2\_eq} = f_a * T_{2b} \leq T_{2\alpha}$$

$$T_{2\_eq} = \text{_____} * \text{_____} \leq T_{2\alpha}$$

$$T_{2\_eq} = \text{_____} \text{ [Nm]} \leq \text{_____} \text{ [Nm]}$$

## Step 5: Quick selection of the technical data

		NPR 015		NPR 025		NPR 035		NPR 045	
		1-stage	2-stage	1-stage	2-stage	1-stage	2-stage	1-stage	2-stage
Ratio <sup>a)</sup>		3-10	12-100	3-10	9-100	3-10	9-100	5-10	25-100
Maximum torque <sup>a)</sup>	$T_{2\alpha}$	Nm 51-64		128-160		320-408		640-800	
		in.lb 450-570		1130-1420		2800-3600		5700-7100	
Maximum torque <sup>a)</sup>	$T_{2\alpha}$	Nm 62-88		168-200		432-488		-	
		in.lb 550-780		1490-1770		3800-4300		-	
Max. input speed	$n_{1max}$	8000	10000	7000	8000	6000	7000	4000	6000
Nominal input speed	$n_{1N}$	2600	3800	2400	2800	1800	2600	1600	2300
Max. radial force	$F_{2RM}$	N 2800		4200		6600		9900	
		lb <sub>f</sub> 630		950		1490		2230	
Mean operating noise	$L_{PA}$	dB(A) ≤ 58		≤ 60		≤ 63		≤ 66	
Paint		Paint Pearl dark grey – innovation blue							
Direction of rotation		Motor and gearhead same direction							
Protection class		IP 65							
Page		6		8		10		12	

<sup>a)</sup> The maximum torques depend on the ratio

You can select a suitable adapter plate using the online configurator on [www.wittenstein-alpha.com](http://www.wittenstein-alpha.com)  
For application-specific sizing with cymex®, see [www.cymex.com](http://www.cymex.com) Please refer to the product pages for detailed information on individual gearhead sizes

### Account must be taken of the radial and axial forces at the output:

Please also carry out steps 6 and 7 if forces are present at the output (e.g. if timing belt pulleys, pinions or levers are mounted there).

#### Step 6 (if external forces are present):

Determine the forces acting on the output and check the boundary conditions

Radial force  $F_{2r} = \underline{\hspace{2cm}}$  [N]  
 Radial force distance  $x_2 = \underline{\hspace{2cm}}$  [mm]  
 Axial force  $F_{2a} = \underline{\hspace{2cm}}$  [N]  
 Axial force distance  $y_2 = \underline{\hspace{2cm}}$  [mm]  
 (required if  $F_{2a}$  is present)

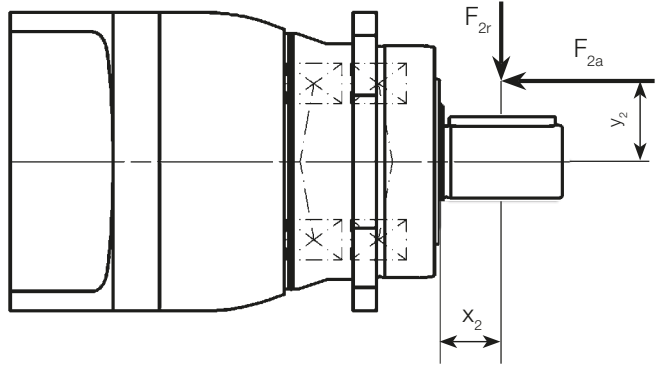

#### Conditions if axial force $F_{2a}$ is present:

1.  $F_{2a} \leq 0.25 * F_{2r} \Rightarrow (\underline{\hspace{2cm}} \leq 0.25 * \underline{\hspace{2cm}})$   Met  Not met: Sizing with cymex®
2.  $y_2 \leq x_2 \Rightarrow (\underline{\hspace{2cm}} \leq \underline{\hspace{2cm}})$   Met  Not met: Sizing with cymex®

#### Step 7:

Determine the maximum equivalent force acting on the output  $F_{2_{eq}}$

$$F_{2_{eq}} = F_{2r} + 0.25 * F_{2a} \leq F_{2RMax} \quad (F_{2RMax} \text{ can be determined from the diagram below})$$

$$F_{2_{eq}} = \underline{\hspace{2cm}} + 0.25 * \underline{\hspace{2cm}} \leq \underline{\hspace{2cm}}$$

$$F_{2_{eq}} = \underline{\hspace{2cm}} \text{ [N]} \leq \underline{\hspace{2cm}} \text{ [N]} \quad \text{  Met }$$

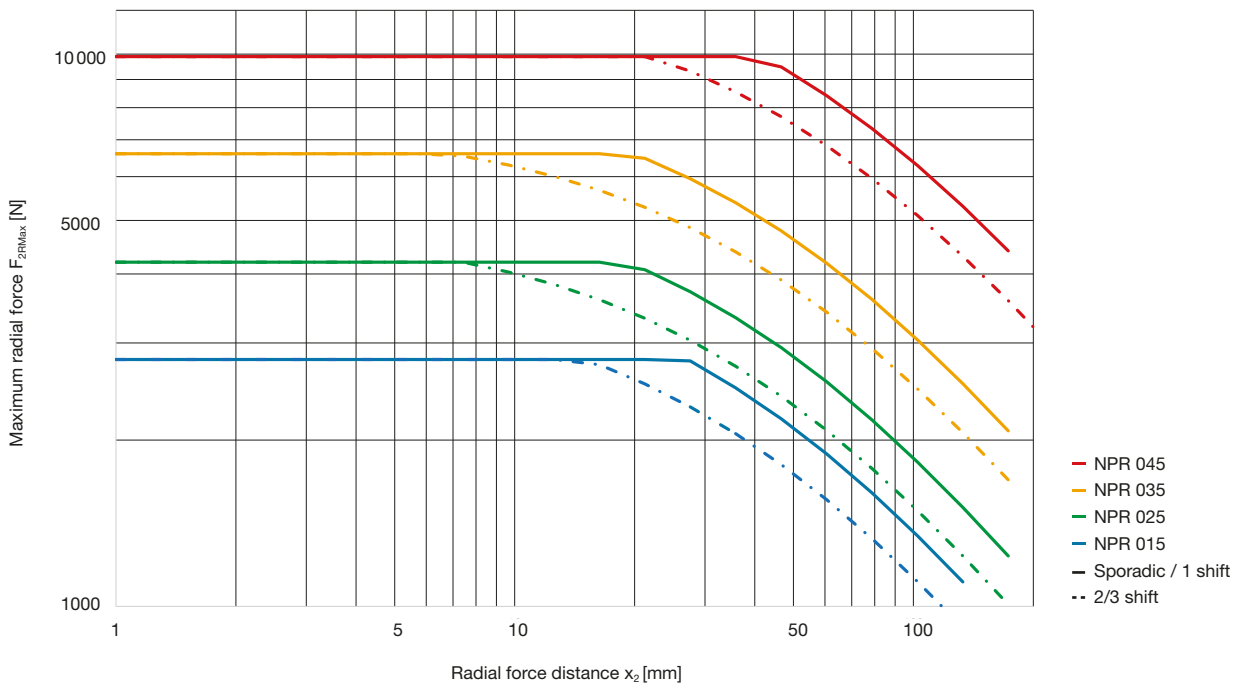

				1-stage						2-stage													
Ratio <sup>a)</sup>		i		3	4	5	7	8	10	12	15	16	20	25	28	30	32	35	40	50	64	70	100
Maximum torque	MF	$T_{2a}$	Nm	51	56	64	64	56	56	51	51	56	56	64	56	51	56	64	56	64	56	64	56
			in.lb	450	500	570	570	500	500	450	450	500	500	570	500	450	500	570	500	570	500	570	500
Maximum torque	HIGH TORQUE – MA	$T_{2a}$	Nm	88	67	-	-	-	-	62	67	67	67	-	67	62	-	-	67	-	-	-	-
			in.lb	780	590	-	-	-	-	550	590	590	590	-	590	550	-	-	590	-	-	-	-
Emergency stop torque <sup>b)</sup>		$T_{2Not}$	Nm	75																			
			in.lb	660																			
Nominal input speed <sup>c)</sup>		$n_{1N}$	min <sup>-1</sup>	2600			3400			3800					4300								
Max. input speed		$n_{1Max}$	min <sup>-1</sup>	8000						10000													
Max. torsional backlash		$j_t$	arcmin	Standard ≤ 8						Standard ≤ 10													
Max. axial force <sup>d)</sup>		$F_{2AMax}$	N	2400																			
			lb <sub>f</sub>	540																			
Max. radial force <sup>d)</sup>		$F_{2RMMax}$	N	2800																			
			lb <sub>f</sub>	630																			
Weight incl. standard adapter plate <sup>e)</sup>		m	kg	1.9 - 3.1						2 - 3													
			lb <sub>m</sub>	4.2 - 6.9						4.4 - 6.6													
Operating noise <sup>f)</sup>		$L_{PA}$	dB(A)	≤ 59						≤ 58													
Max. permitted housing temperature			°C	+90																			
			F	+194																			
Ambient temperature			°C	-15 to +40																			
			F	5 to 104																			
Lubrication				Lubricated for life																			
Paint				Housing: pearl dark grey / Drive-Side: Innovation Blue																			
Direction of rotation				Motor and gearhead same direction																			
Type of protection				IP 65																			
Moment of inertia (related to the drive)			kgcm <sup>2</sup>	0.13 to 0.55						0.02 to 0.14													
			10 <sup>-3</sup> in.lb.s <sup>2</sup>	0.12 to 0.49						0.02 to 0.13													
Clamping hub diameter	Standard		mm	9(A) 11(B) 14(C)						8(Z) 9(A) 11(B)													
				big	16(D) 19(E)						14(C)												

<sup>a)</sup> Other ratios available on request.

<sup>b)</sup> Permitted 1000 times during the service life of the gearhead. If  $T_{2a} > T_{2Not}$  then  $T_{2Not}$  is the maximum permitted value.

<sup>c)</sup> At  $T_{2N}$  and 20°C ambient temperature. Higher speeds possible if calculated using cymex®.

<sup>d)</sup> Refers to the center of the output shaft at  $n_2 = 150$  rpm.

<sup>e)</sup> Depending on the clamping hub diameter and the selected adapter plate.

<sup>f)</sup> At  $i = 10$  and  $n_1 = 3000$  rpm at no load.

You can select a suitable adapter plate using the online configurator on [www.wittenstein-alpha.com](http://www.wittenstein-alpha.com)

Quick gearhead selection based on the motor characteristic\*:

Max. torque  $T_{2a} \geq T_{max\ motor} \cdot i$

\*Please refer to catalog pages 4 and 5 for detailed information on manual selection based on the application.

For application-specific sizing with cymex®, see [www.cymex.com](http://www.cymex.com)

Motor shaft diameter [mm]

1-stage

Up to 14<sup>4)</sup> (C) clamping hub diameter

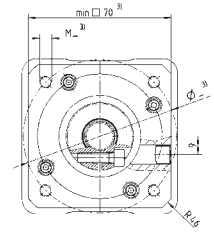
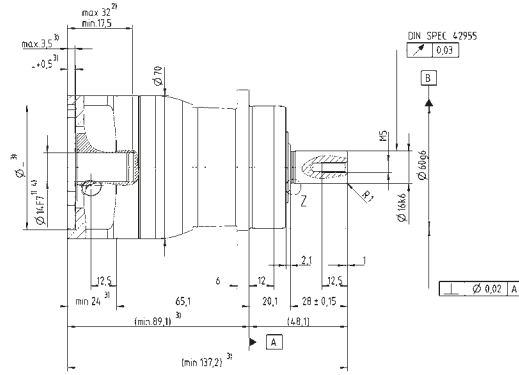
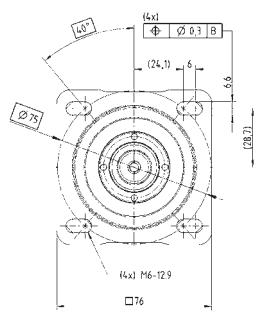

Up to 19<sup>4)</sup> (E) clamping hub diameter

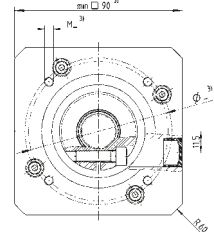
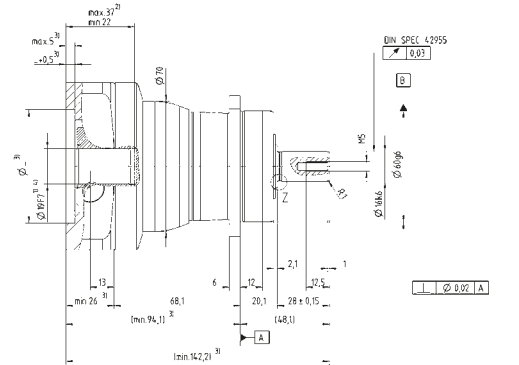
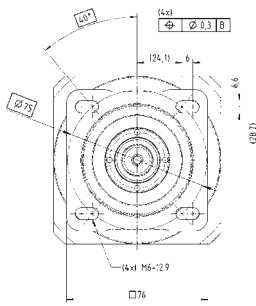

2-stage

Up to 11<sup>4)</sup> (B) clamping hub diameter

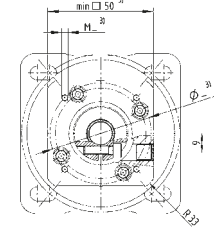
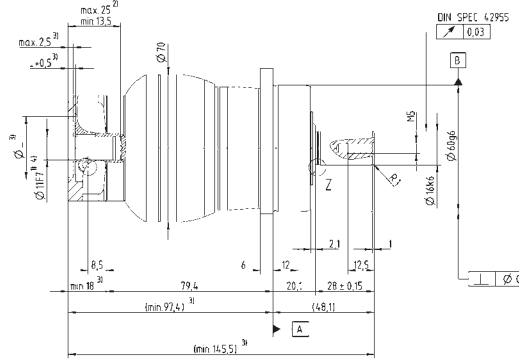
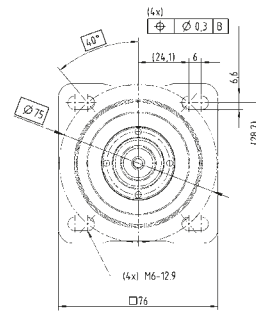

Up to 14<sup>4)</sup> (C) clamping hub diameter

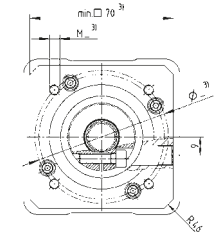
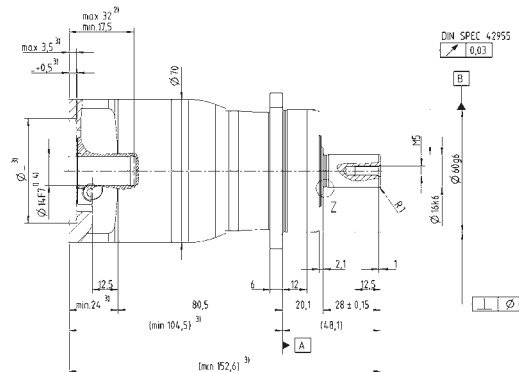
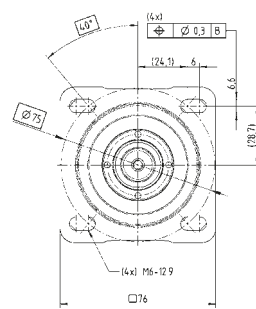

Alternatives: Output shaft variants

Output shaft with key  
E = key as per DIN 6885, sheet 1, form A

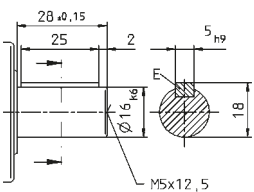

Splined shaft  
X = W 16 x 0.8 x 30 x 18 x 6m, DIN 5480

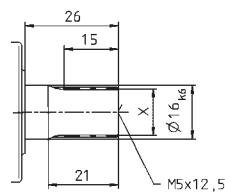

Non-tolerated dimensions  $\pm 1$  mm

- 1) Check motor shaft fit.
- 2) Min. / max. permissible motor shaft length. Longer motor shafts are adaptable; please contact us.
- 3) The dimensions depend on the motor.
- 4) Smaller motor shaft diameters are compensated by a bushing with a minimum thickness of 1 mm.

⚠ Motor mounting according to operating manual



				1-stage						2-stage														
Ratio <sup>a)</sup>		i		3	4	5	7	8	10	9	12	15	16	20	25	28	30	32	35	40	50	64	70	100
Maximum torque	MF	$T_{2a}$	Nm	128	152	160	160	144	144	128	128	128	152	152	160	152	128	144	160	152	160	144	160	144
			in.lb	1130	1350	1420	1420	1270	1270	1130	1130	1130	1350	1350	1420	1350	1130	1270	1420	1350	1420	1270	1420	1270
Maximum torque	HIGH TORQUE – MA	$T_{2a}$	Nm	200	184	-	-	-	-	200	200	192	184	184	-	184	168	-	-	184	-	-	-	-
			in.lb	1170	1630	-	-	-	-	1770	1770	1700	1630	1630	-	1630	1490	-	-	1630	-	-	-	-
Emergency stop torque <sup>b)</sup>		$T_{2Not}$	Nm	190																				
			in.lb	1700																				
Nominal input speed <sup>c)</sup>		$n_{1N}$	min <sup>-1</sup>	2400				3000				2800					4000							
Max. input speed		$n_{1Max}$	min <sup>-1</sup>	7000						8000														
Max. torsional backlash		$j_t$	arcmin	Standard ≤ 8						Standard ≤ 10														
Max. axial force <sup>d)</sup>		$F_{2AMax}$	N	3350																				
			lb <sub>f</sub>	750																				
Max. radial force <sup>d)</sup>		$F_{2RMMax}$	N	4200																				
			lb <sub>f</sub>	950																				
Weight incl. standard adapter plate <sup>e)</sup>		m	kg	3.7 - 6						4 - 6														
			lb <sub>m</sub>	8.2 - 13.3						8.8 - 13.3														
Operating noise <sup>f)</sup>		$L_{PA}$	dB(A)	≤ 61						≤ 59														
Max. permitted housing temperature			°C	+90																				
			F	+194																				
Ambient temperature			°C	-15 to +40																				
			F	5 to 104																				
Lubrication				Lubricated for life																				
Paint				Housing: pearl dark grey / Drive-Side: Innovation Blue																				
Direction of rotation				Motor and gearhead same direction																				
Type of protection				IP 65																				
Moment of inertia (related to the drive)			kgcm <sup>2</sup>	0.26 to 1.8						0.19 to 0.56														
			10 <sup>-3</sup> in.lb.s <sup>2</sup>	0.23 to 1.6						0.17 to 0.5														
Clamping hub diameter	Standard		mm	14(C) 16(D) 19(E)						9(A) 11(B) 14(C)														
				big	24(G) 28(H)						16 (D) 19(E)													

<sup>a)</sup> Other ratios available on request.

<sup>b)</sup> Permitted 1000 times during the service life of the gearhead. If  $T_{2a} > T_{2Not}$ , then  $T_{2Not}$  is the maximum permitted value.

<sup>c)</sup> At  $T_{2N}$  and 20°C ambient temperature. Higher speeds possible if calculated using cymex®.

<sup>d)</sup> Refers to the center of the output shaft at  $n_2 = 150$  rpm.

<sup>e)</sup> Depending on the clamping hub diameter and the selected adapter plate.

<sup>f)</sup> At  $i = 10$  and  $n_1 = 3000$  rpm at no load.

You can select a suitable adapter plate using the online configurator on [www.wittenstein-alpha.com](http://www.wittenstein-alpha.com)

Quick gearhead selection based on the motor characteristic\*:

Max. torque  $T_{2a} \geq T_{max\ motor} \cdot i$

\*Please refer to catalog pages 4 and 5 for detailed information on manual selection based on the application.

For application-specific sizing with cymex®, see [www.cymex.com](http://www.cymex.com)

1-stage

Up to 19<sup>4)</sup> (E) clamping hub diameter

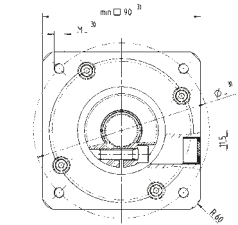
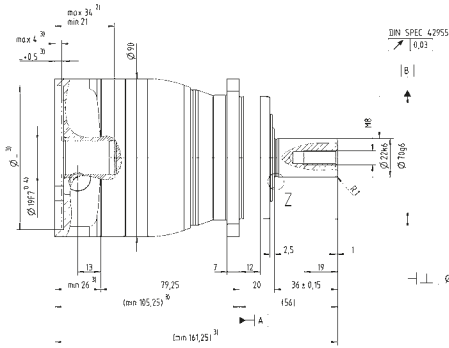
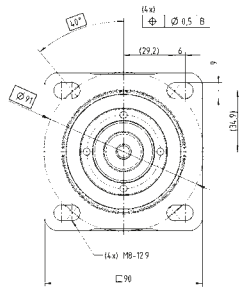

Up to 28<sup>4)</sup> (H) clamping hub diameter

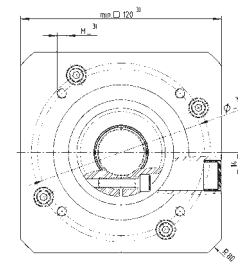
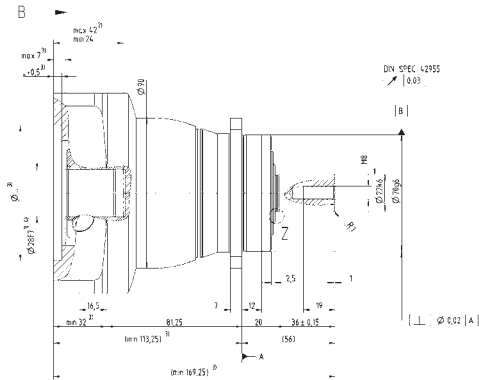
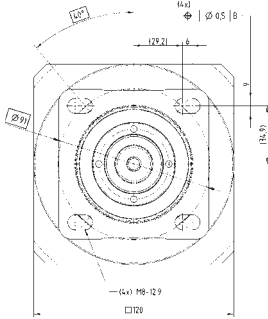

Up to 14<sup>4)</sup> (C) clamping hub diameter

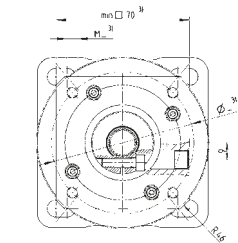
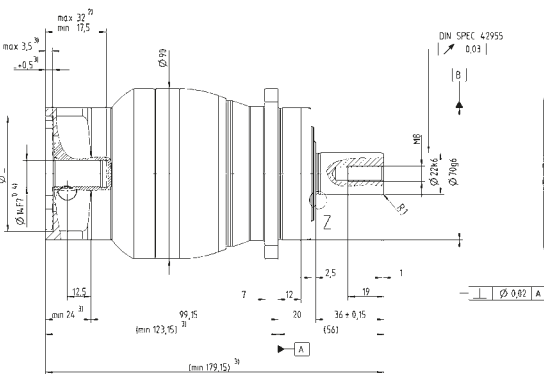
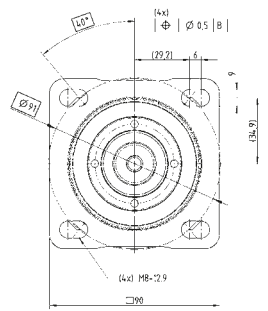

2-stage

Up to 19<sup>4)</sup> (E) clamping hub diameter

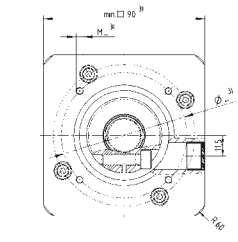
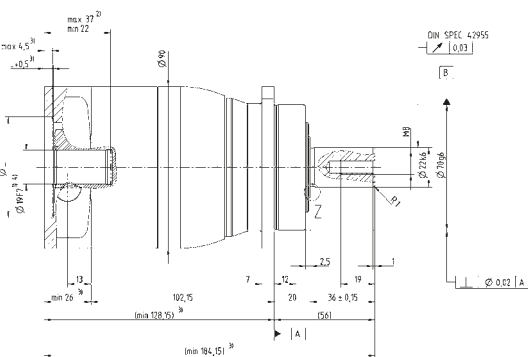
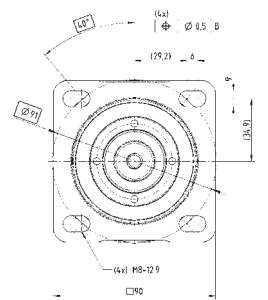

Alternatives: Output shaft variants

Output shaft with key  
E = key as per DIN 6885, sheet 1, form A

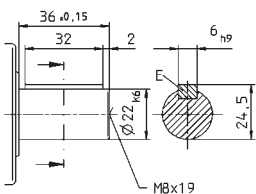

Splined shaft  
X = W 22 x 1.25 x 30 x 16 x 6m, DIN 5480

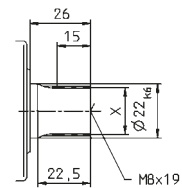

Non-tolerated dimensions ± 1 mm

- 1) Check motor shaft fit.
- 2) Min. / max. permissible motor shaft length. Longer motor shafts are adaptable; please contact us.
- 3) The dimensions depend on the motor.
- 4) Smaller motor shaft diameters are compensated by a bushing with a minimum thickness of 1 mm.

⚠ Motor mounting according to operating manual

Ratio <sup>a)</sup>	i	1-stage										2-stage												
		3	4	5	7	8	10	9	12	15	16	20	25	28	30	32	35	40	50	64	70	100		
Maximum torque	MF	$T_{2a}$	Nm	320	408	400	400	352	352	320	320	320	408	408	400	408	320	408	400	408	400	352	400	352
			in.lb	2800	3600	3500	3500	3100	3100	2800	2800	2800	3600	3600	3500	3600	2800	3600	3500	3600	3500	3100	3500	3100
Maximum torque	HIGH TORQUE – MA	$T_{2a}$	Nm	488	488	-	-	-	-	488	488	480	488	488	-	488	432	-	-	488	-	-	-	-
			in.lb	4300	4300	-	-	-	-	4300	4300	4200	4300	4300	-	4300	3800	-	-	4300	-	-	-	-
Emergency stop torque <sup>b)</sup>		$T_{2Not}$	Nm	480																				
			in.lb	4200																				
Nominal input speed <sup>c)</sup>	$n_{1N}$	min <sup>-1</sup>	1800					2300					2600					3600						
Max. input speed	$n_{1Max}$	min <sup>-1</sup>	6000										7000											
Max. torsional backlash	$j_t$	arcmin	Standard ≤ 8										Standard ≤ 10											
Max. axial force <sup>d)</sup>	$F_{2AMax}$	N	5650																					
		lb <sub>f</sub>	1270																					
Max. radial force <sup>d)</sup>	$F_{2RMMax}$	N	6600																					
		lb <sub>f</sub>	1490																					
Weight incl. standard adapter plate <sup>e)</sup>	m	kg	8.6 - 14.5										9 - 14.1											
		lb <sub>m</sub>	19 - 32										20 - 31											
Operating noise <sup>f)</sup>	$L_{PA}$	dB(A)	≤ 65										≤ 61											
Max. permitted housing temperature			+90																					
			+194																					
Ambient temperature			-15 to +40																					
			5 to +104																					
Lubrication			Lubricated for life																					
Paint			Housing: pearl dark grey / Drive-Side: Innovation Blue																					
Direction of rotation			Motor and gearhead same direction																					
Type of protection			IP 65																					
Moment of inertia (related to the drive)			kgcm <sup>2</sup>										0.24 to 1.9											
			10 <sup>-3</sup> in.lb.s <sup>2</sup>										0.21 to 1.7											
Clamping hub diameter	Standard	mm	19(E) 24(G) 28(H)										14(C) 16(D) 19(E)											
	big		32(I) 38(K)										24(G) 28(H)											

<sup>a)</sup> Other ratios available on request.

<sup>b)</sup> Permitted 1000 times during the service life of the gearhead. If  $T_{2a} > T_{2Not}$  then  $T_{2Not}$  is the maximum permitted value.

<sup>c)</sup> At  $T_{2N}$  and 20°C ambient temperature. Higher speeds possible if calculated using cymex®.

<sup>d)</sup> Refers to the center of the output shaft at  $n_2 = 150$  rpm.

<sup>e)</sup> Depending on the clamping hub diameter and the selected adapter plate.

<sup>f)</sup> At  $i=10$  and  $n_1=3000$  rpm at no load.

You can select a suitable adapter plate using the online configurator on [www.wittenstein-alpha.com](http://www.wittenstein-alpha.com)

Quick gearhead selection based on the motor characteristic\*:

Max. torque  $T_{2a} \geq T_{max\ motor} \cdot i$

\*Please refer to catalog pages 4 and 5 for detailed information on manual selection based on the application.

For application-specific sizing with cymex®, see [www.cymex.com](http://www.cymex.com)

Motor shaft diameter [mm]

1-stage

Up to 28<sup>4)</sup> (H) clamping hub diameter

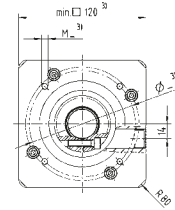
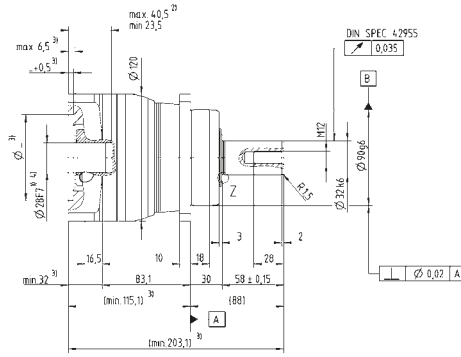
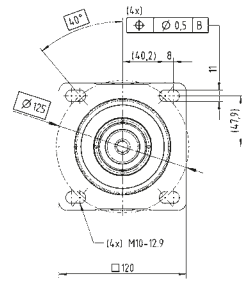

Up to 38<sup>4)</sup> (K) clamping hub diameter

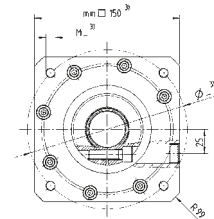
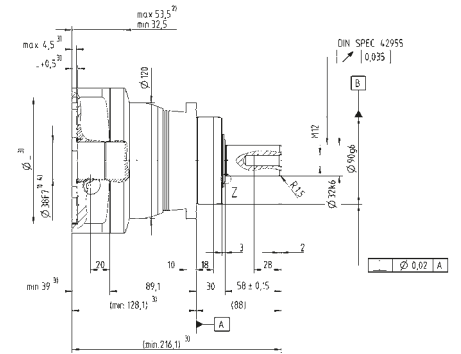
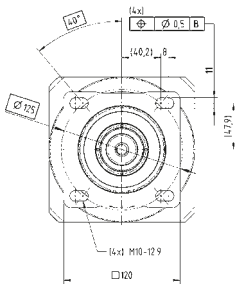

2-stage

Up to 19<sup>4)</sup> (E) clamping hub diameter

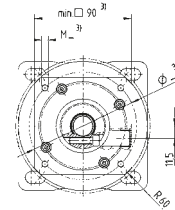
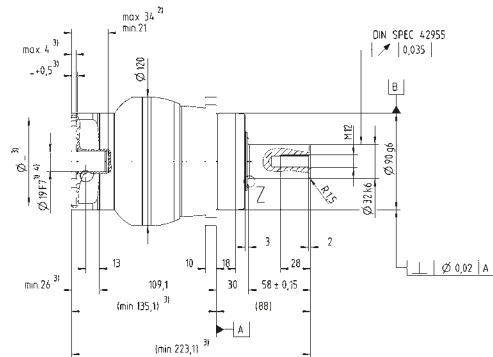
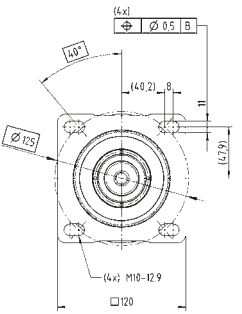

Up to 28<sup>4)</sup> (H) clamping hub diameter

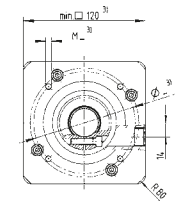
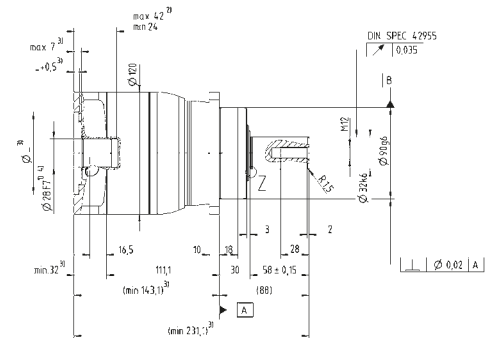
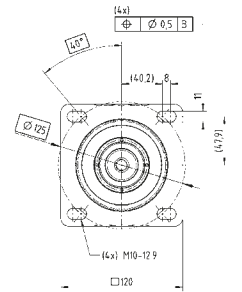

Alternatives: Output shaft variants

Output shaft with key  
E = key as per DIN 6885, sheet 1, form A

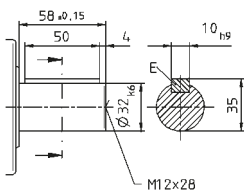

Splined shaft  
X = W 32 x 1.25 x 30 x 24 x 6m, DIN 5480

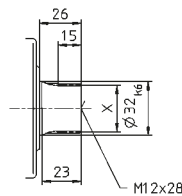

Non-tolerated dimensions ± 1 mm

- 1) Check motor shaft fit.
- 2) Min. / max. permissible motor shaft length.  
Longer motor shafts are adaptable; please contact us.
- 3) The dimensions depend on the motor.
- 4) Smaller motor shaft diameters are compensated by a bushing with a minimum thickness of 1 mm.

⚠ Motor mounting according to operating manual

Ratio <sup>a)</sup>	i	1-stage			2-stage					
		5	8	10	25	32	50	64	100	
Maximum torque	MF $T_{2a}$	Nm	800	640	640	800	640	800	640	640
		in.lb	7100	5700	5700	7100	5700	7100	5700	5700
Emergency stop torque <sup>b)</sup>	$T_{2Not}$	Nm	1000							
		in.lb	8900							
Nominal input speed <sup>c)</sup>	$n_{1N}$	min <sup>-1</sup>	1600	1800		2600				
Max. input speed	$n_{1Max}$	min <sup>-1</sup>	4000			6000				
Max. torsional backlash	$j_t$	arcmin	Standard ≤ 8			Standard ≤ 10				
Max. axial force <sup>d)</sup>	$F_{2AMax}$	N	9870							
		lb <sub>f</sub>	2200							
Max. radial force <sup>d)</sup>	$F_{2RMax}$	N	9900							
		lb <sub>f</sub>	2200							
Weight incl. standard adapter plate <sup>e)</sup>	m	kg	19.5 - 25.5			20 - 29.5				
		lb <sub>m</sub>	43 - 56			44 - 65				
Operating noise <sup>f)</sup>	$L_{PA}$	dB(A)	≤ 68			≤ 65				
Max. permitted housing temperature	°C		+90							
	F		+194							
Ambient temperature	°C		-15 to +40							
	F		5 to +104							
Lubrication	Lubricated for life									
Paint	Housing: pearl dark grey / Drive-Side: Innovation Blue									
Direction of rotation	Motor and gearhead same direction									
Type of protection	IP 65									
Moment of inertia (related to the drive)	kgcm <sup>2</sup>		7.2 to 8.7			0.82 to 7.6				
	10 <sup>-3</sup> in.lb.s <sup>2</sup>		6.3 to 7.7			0.73 to 6.7				
Clamping hub diameter	Standard	mm	38(K)			19(E) 24(G) 28(H)				
	big		-			32(I) 38(K)				

<sup>a)</sup> Other ratios available on request.

<sup>b)</sup> Permitted 1000 times during the service life of the gearhead. If  $T_{2a} > T_{2Not}$ , then  $T_{2Not}$  is the maximum permitted value.

<sup>c)</sup> At  $T_{2N}$  and 20°C ambient temperature. Higher speeds possible if calculated using cymex<sup>®</sup>.

<sup>d)</sup> Refers to the center of the output shaft at  $n_2 = 150$  rpm.

<sup>e)</sup> Depending on the clamping hub diameter and the selected adapter plate.

<sup>f)</sup> At  $i=10$  and  $n_1=3000$  rpm at no load.

You can select a suitable adapter plate using the online configurator on [www.wittenstein-alpha.com](http://www.wittenstein-alpha.com)

Quick gearhead selection based on the motor characteristic\*:

Max. torque  $T_{2a} \geq T_{max\ motor} \cdot i$

\*Please refer to catalog pages 4 and 5 for detailed information on manual selection based on the application.

For application-specific sizing with cymex<sup>®</sup>, see [www.cymex.com](http://www.cymex.com)

Motor shaft diameter [mm]

1-stage

Up to 38<sup>4)</sup> (K)  
clamping hub diameter

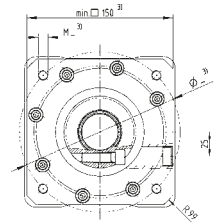
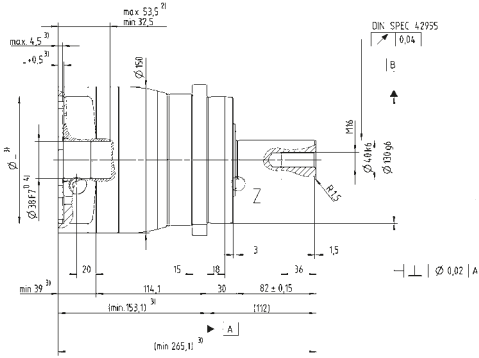
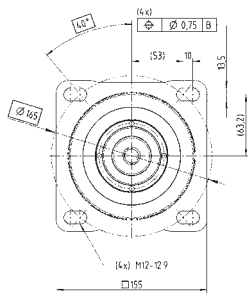

2-stage

Up to 28<sup>4)</sup> (H)  
clamping hub diameter

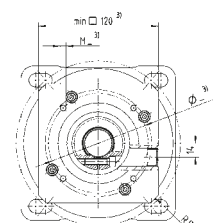
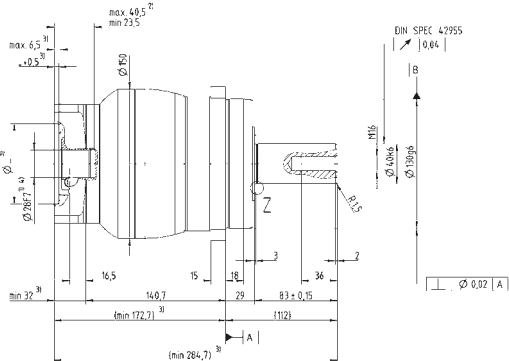
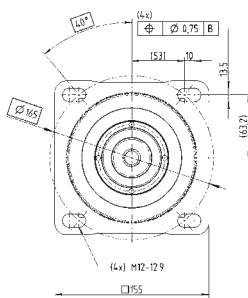

Up to 38<sup>4)</sup> (K)  
clamping hub diameter

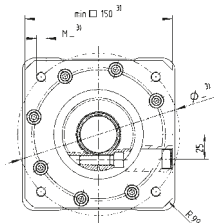
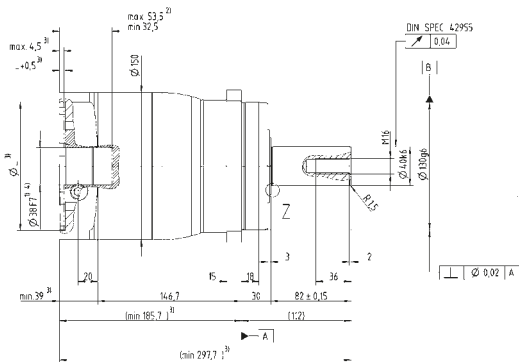
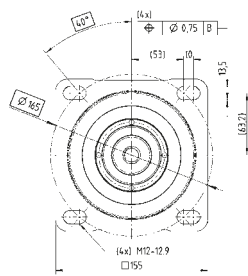

Alternatives: Output shaft variants

Output shaft with key

E = key as per DIN 6885, sheet 1, form A

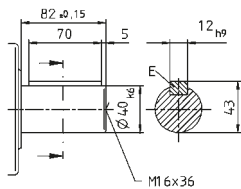

Splined shaft

X = W 40 x 2 x 30 x 18 x 6m, DIN 5480

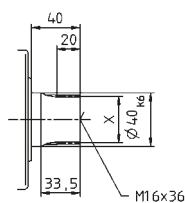

Non-tolerated dimensions ±1 mm

- 1) Check motor shaft fit.
- 2) Min. / max. permissible motor shaft length.  
Longer motor shafts are adaptable; please contact us.
- 3) The dimensions depend on the motor.
- 4) Smaller motor shaft diameters are compensated by a bushing with a minimum thickness of 1 mm.

⚠ Motor mounting according to operating manual

## Equivalent force at the output ( $F_{2_{eq}}$ )

The equivalent force  $F_{2_{eq}}$  at the output describes the decisive forces for gearhead selection.

## Equivalent application torque ( $T_{2_{eq}}$ )

The equivalent application torque  $T_{2_{eq}}$  describes the decisive torque for gearhead selection.

## Sizing factor ( $f_a$ )

The sizing factor  $f_a$  describes the influence of the daily operating time and the operating mode factor on the application torque.

## Operating mode factor ( $K_M$ )

The operating mode factor  $K_M$  describes the influence of the duty cycle, the number of cycles and the dynamics on the application torque.

## Moment of inertia (relates to the drive) (J)

The mass moment of inertia J is a measure of the effort applied by an object to maintain its momentary condition (at rest or moving).

## Operating noise ( $L_{PA}$ )

Low noise level  $L_{PA}$  is a factor of growing importance for environmental and health reasons. The gear ratio and speed both affect the noise level.

General rule:

A higher speed means a higher noise level, while a higher ratio means a lower noise level. The values specified in our catalog relate to gearheads with a ratio  $i = 10/100$  at a speed  $n = 3000$  rpm

## Max. radial force ( $F_{2R}$ )

The radial force  $F_{2R}$  is the force component acting at right angles to the output shaft with the NP, NPS, NPR and NPL or parallel to the output flange with the NPT. It acts perpendicular to the axial force and can assume an axial distance of  $x_2$  in relation to the shaft shoulder with the NP, NPS, NPR and NPL or to the shaft flange with the NPT, which acts as a lever arm. The lateral force produces a bending moment.

## Max. input speed ( $n_{1max}$ ) and nominal input speed ( $n_{1N}$ )

Two speeds are of relevance when sizing a gearhead: the maximum speed and the nominal speed at the input. The maximum permissible speed  $n_{1max}$  must not be exceeded because it serves as the basis for sizing  $\rightarrow$  cyclic operation. The nominal speed  $n_{1N}$  must not be exceeded in  $\rightarrow$  continuous operation. The housing temperature limits the nominal speed, which must not exceed  $90^\circ\text{C}$ . The nominal input speed specified in the catalogue applies to an ambient temperature of  $20^\circ\text{C}$ . As can be seen in the diagram below, the temperature limit is reached more quickly in the presence of an elevated outside temperature, in other words the nominal input speed must be reduced if the ambient temperature is high. The values applicable to your gearhead are available from WITTENSTEIN alpha on request.

## Max. output torque ( $T_{2a}$ )

$T_{2a}$  is the maximum torque which can be transmitted by the gearhead. This value may be lower, depending on the specific boundary conditions of the application.

## Emergency stop torque ( $T_{2Not}$ )

The emergency stop torque [Nm]  $T_{2Not}$  is the maximum permissible torque at the gearhead output and must not be reached more than 1000 times during the life of the gearhead. It must never be exceeded.

Further information can be found in the glossary of our current product catalog.

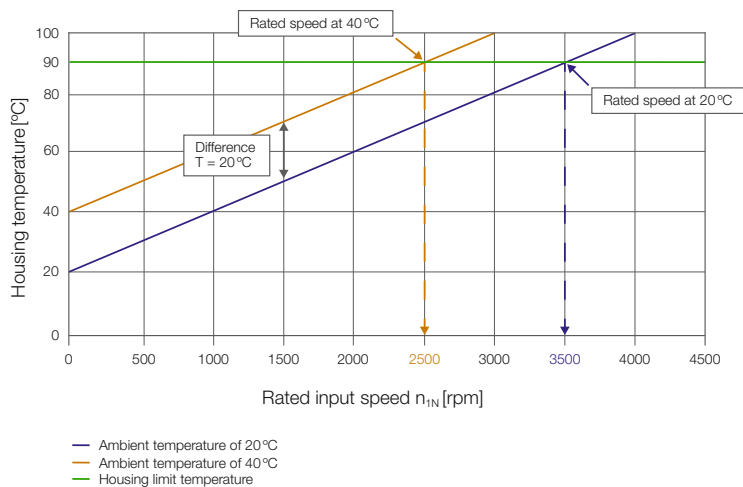

## Order codes for the alpha Value Line – NPR

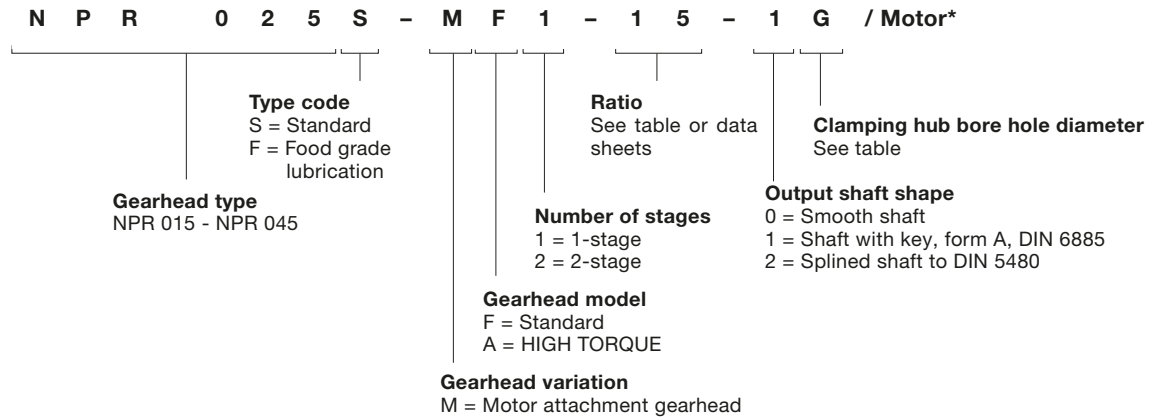

\*Full motor designation only required for determining attached gearhead components!

## Ratio and clamping hub diameter table

Size	Stages	Ratios	Clamping hub diameters* [mm]
005	1 stage	4, 5, 7, 8, 10	8 (Z), 9 (A), 11 (B), 14 (C)
	2 stage	16, 20, 25, 28, 35, 40, 50, 64, 70, 100	8 (Z), 9 (A), 11 (B), 14 (C)
015	1 stage	3, 4, 5, 7, 8, 10	9 (A), 11 (B), 14 (C), 16 (D), 19 (E)
	2 stage	12, 15, 16, 20, 25, 28, 30, 32, 35, 40, 50, 64, 70, 100	8 (Z), 9 (A), 11 (B), 14 (C)
025	1 stage	3, 4, 5, 7, 8, 10	14 (C), 16 (D), 19 (E), 24 (G), 28 (H)
	2 stage	9, 12, 15, 16, 20, 25, 28, 30, 32, 35, 40, 50, 64, 70, 100	9 (A), 11 (B), 14 (C), 16 (D), 19 (E)
035	1 stage	3, 4, 5, 7, 8, 10	19 (E), 24 (G), 28 (H), 32 (I), 38 (K)
	2 stage	9, 12, 15, 16, 20, 25, 28, 30, 32, 35, 40, 50, 64, 70, 100	14 (C), 16 (D), 19 (E), 24 (G), 28 (H)
045	1 stage	5, 8, 10	38 (K)
	2 stage	25, 32, 50, 64, 100	19 (E), 24 (G), 28 (H), 32 (I), 38 (K)

\*Intermediate diameters are possible in combination with a bushing with a minimum thickness of 1 mm.





WITTENSTEIN alpha GmbH · Walter-Wittenstein-Straße 1 · 97999 Igersheim · Tel. +49 7931 493-0 · info@wittenstein-alpha.com

**WITTENSTEIN alpha – intelligent drive systems**

[www.wittenstein-alpha.com/alpha-value-line](http://www.wittenstein-alpha.com/alpha-value-line)

