

4

3

2

1

REVISIONS				
ECO #	REV.	DESCRIPTION	DATE	APPROVED
7135	A	INITIAL RELEASE	1/20/2015	J. KORDIK
8698	B	POWER CONNECTOR PART CHANGE, SPECS ADDED	8/9/2021	M. MARONEY

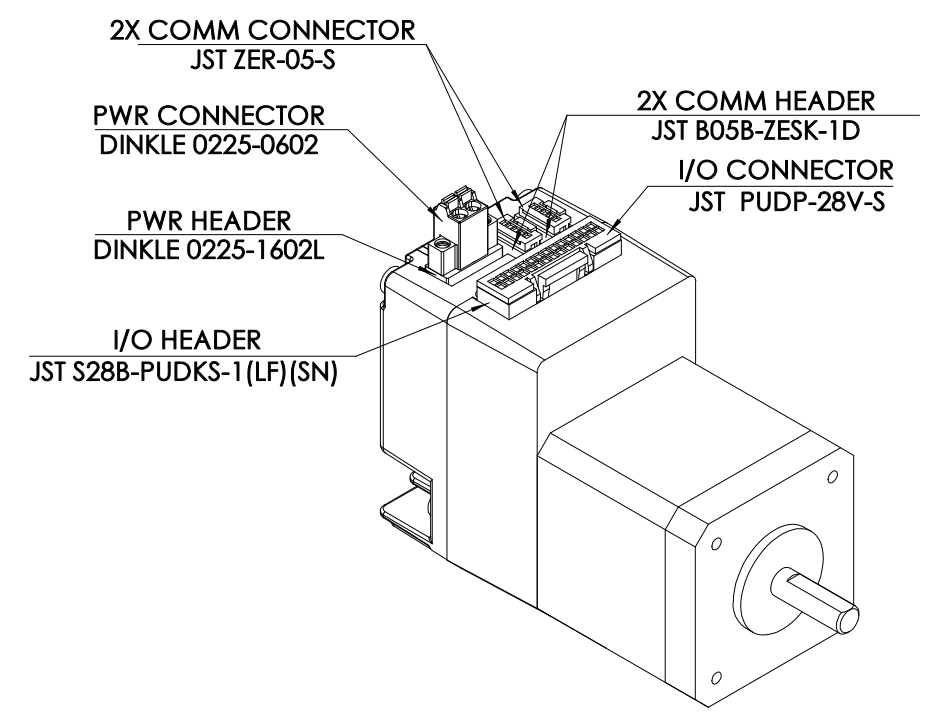
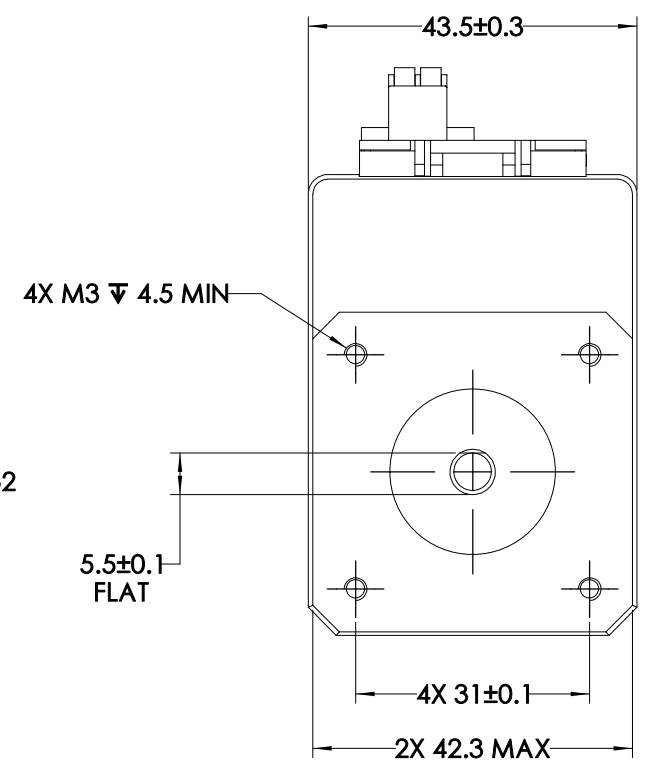
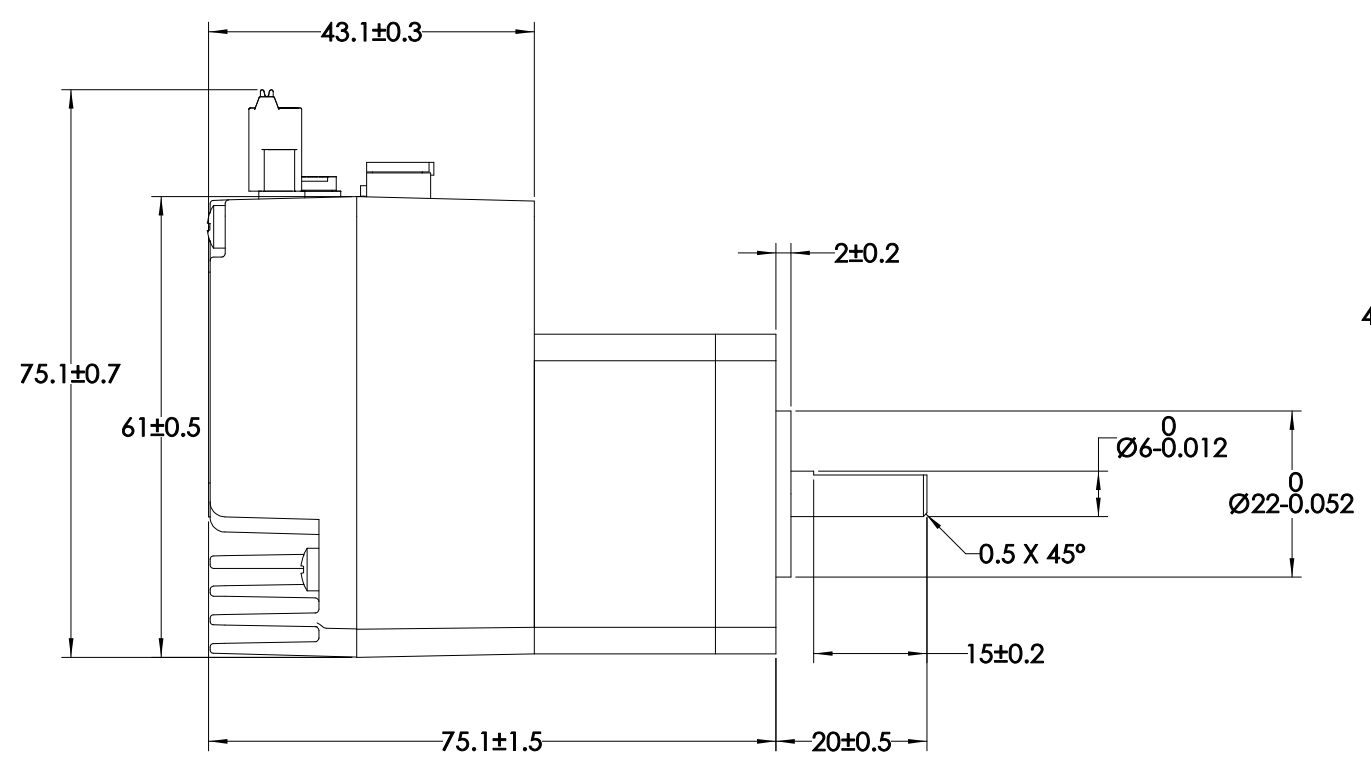

SPECIFICATIONS

INPUT VOLTAGE	12 TO 48 VDC	HOLDING TORQUE	0.5N · m
STEP ANGLE	1.8°	MAX AXIAL LOAD	4.3N [2]
STEP ACCURACY	±0.09°	MAX RADIAL LOAD	20N [2]
OPERATING TEMP	0 TO 40°C	RADIAL PLAY	0.02mm MAX (500gf RADIAL LOAD)
STORAGE TEMP	-20 TO 50°C	END PLAY	0.08mm MAX (500gf AXIAL LOAD)
TEMP RISE	80°C MAX	SHAFT RUNOUT	0.05mm T.I.R. MAX
ROTOR INERTIA	57g · cm ²	WEIGHT	440g
IP RATING	IP20	APPROVALS	CE, RoHS

NOTES:

- REFER TO PRODUCT HARDWARE MANUAL ON APPLIED-MOTION.COM FOR MORE DETAILS.
- SHAFT LOADS FOR L₁₀ LIFE OF 20,000 HOURS AT 1000 RPM. RADIAL LOAD AT END OF SHAFT.

<p>Applied Motion Products A MOONS' COMPANY</p> <p>PROPRIETARY AND CONFIDENTIAL</p> <p>THE INFORMATION CONTAINED IN THIS DRAWING IS THE SOLE PROPERTY OF APPLIED MOTION PRODUCTS. ANY REPRODUCTION IN PART OR AS A WHOLE WITHOUT THE WRITTEN PERMISSION OF APPLIED MOTION PRODUCTS IS PROHIBITED.</p>	THIRD ANGLE PROJECTION		NAME	DATE	TITLE: INTEGRATED StepSERVO MOTOR
	UNLESS OTHERWISE SPECIFIED: DIMENSIONS ARE IN MILLIMETERS	DRAWN	Tang Jiadong	Jul 19, 2021	
	TOLERANCES: - ANGULAR: ± 0.5 - ONE DECIMAL PLACE: ± 0.25 - TWO DECIMAL PLACES: ± 0.13	PRE.CHECK	Guo Wenxiang	Jul 19, 2021	
	MATERIAL	PRE.APPROVAL	Wang Wei	Jul 19, 2021	
	FINISH	FIN.CHECK	Y. Lapnet	Aug 09, 2021	
DO NOT SCALE DRAWING	COMMENTS:				SIZE DWG. NO. REV B TSM17C-2CG B
		SCALE: 1:1		SHEET 1 OF 1	

4

3

2

1