

Motor Specifications

1	Drive Input from Power Supply		208~240VAC
2	Basic DC Bus Voltage	V (DC)	320V
3	Rated Output Power	Watts	400
4	Rated Speed	rpm	3000
5	Max. Mechanical Speed	rpm	6000
6	Rated Torque	Nm	1.27
7	Continuous Stall Torque	Nm	1.3
8	Peak Torque	Nm	3.8
9	Rated Current	A (rms)	2.8
10	Continuous Stall Current	A (rms)	2.8
11	Peak Current	A (rms)	10
12	Voltage Constant ±10%	V(rms)/K rpm	28.3
13	Torque Constant ±10%	Nm/A(rms)	0.454
14	Winding Resistance(Line-Line)±10%	Ohm @20°C	3.57
15	Winding Inductance(Line-Line)±20%	mH	13.8
16	Inertia	kg m ²	0.0000237
17	Thermal Resistance(mounted)	°C / W	1.21
18	Thermal Time Constant	Minutes	12 Min
19	Heat Sink Size(Iron)	mm	250×250×6
20	Shaft Load - Axial	N (max.)	70 N / 15 Lbf
21	Shaft Load - Radial(End of Shaft)	N (max.)	240 N / 54 Lbf
22	Weight	kg	1.4 kg /3.08 Lb
23	Approvals	cULus,CE,RoHS	
24	Encoder	17 bit,Battery-less Absolute Multi-turn Encoder(Fraba)	
25	Insulation Class	F (155°C)	
26	IP rating	IP65(except shaft through hole and cable end connector)	
27	Installation Location	Indoors, free from direct sunlight, corrosive gas, inflammable gas	
28	Ambient Temperature	Operating 0 to 40°C, Storage -20 to 80°C	
29	Ambient Humidity (max.)	85% (free from condensing)	
30	Altitude (max.)	1000 m	
31	Vibration Resistance	49 m/s ²	
32	Rotor Poles	10	

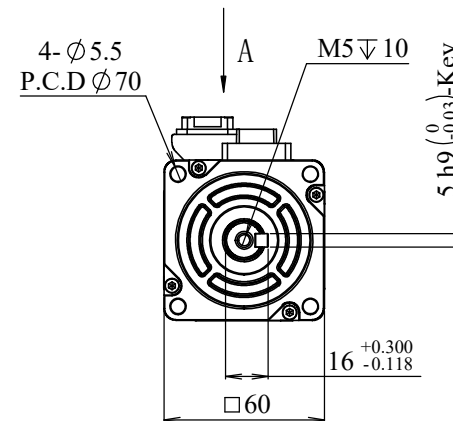
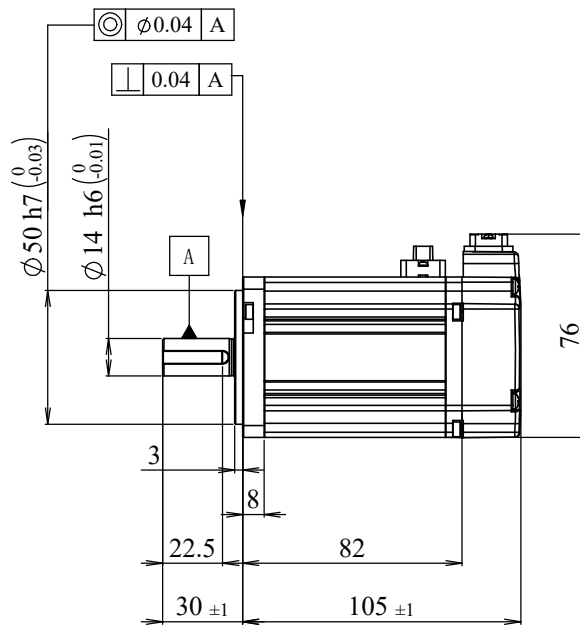

View A

View A

Motor Power Connector:
DGFA4S-A2-00A(H)

Encoder Connector:
DGFA9S-A1-02A(H)
Pin: DGFA-02A(H)

Shaft Load: (L₁₀ life, 20,000 hours, 2,000 RPM)

Motor Phases

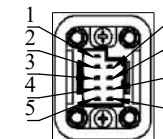
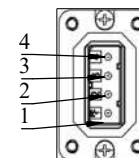
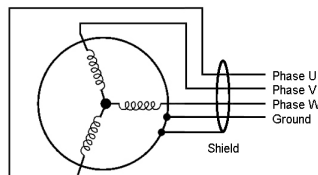
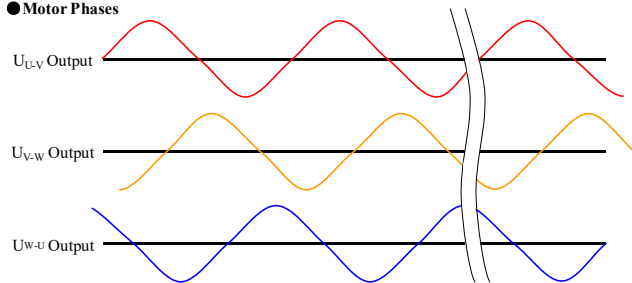

All the timing logics are obtained in CCW rotation as viewed from front shaft.

PIN#	Signal	PIN#	1	2	3	4	5	6	7	8	9
1	FG	Signal	Shield	CLK+	CLK-	Data-	Data+	5V	n/c	GND	n/c
2	Phase U										
3	Phase V										
4	Phase W										

Notes:

1. A shaft seal is shipped with motor, but not installed.
2. A KEY is shipped with motor, but not installed.

Item Number
S0032

Unit: mm	
First Angle Method	
Tolerances for linear and angular dimensions without individual tolerance indications	
GB/T 1804-m eqv ISO 2768-1:m	
Geometrical tolerance for features without individual tolerance indications	
GB/T 1184-K eqv ISO 2768-2:K	
UNLESS OTHERWISE SPECIFIED	

AO	Preliminary	2023.06.13
REV	Sign	Quantity
Design	ECN NO.	Date
Standard	Technology	
Check	Audit	
Marketing Dep	Approve	Date



SM3L-062ABNDV		
4611170000694		
Stage	Quality	Scale
D		1:2
Sheet	1 of 1	

Shanghai AMP & MOONS' Automation Co.,Ltd