

### Motor Specifications

1	Drive Input power supply		208~240VAC
2	Basic DC Bus Voltage	V (DC)	320V
3	Rated Output Power	Watts	850
4	Rated Speed	rpm	1500
5	Max. Mechanical Speed	rpm	3000
6	Rated Torque	Nm	5.39
7	Continuous Stall Torque	Nm	5.8
8	Peak Torque	Nm	16.2
9	Rated Current	A (rms)	6
10	Continuous Stall Current	A (rms)	6
11	Peak Current	A (rms)	19
12	Voltage Constant ±10%	V(rms)/K rpm	55.3
13	Torque Constant ±10%	Nm/A(rms)	0.898
14	Winding Resistance(Line-Line)±10%	Ohm @20°C	1.08
15	Winding Inductance(Line-Line)±20%	mH	9
16	Inertia	kg m <sup>2</sup>	0.0013
17	Thermal Resistance(mounted)	°C / W	0.66
18	Thermal Time Constant	Minutes	24 Min
19	Heat Sink Size(iron)	mm	400×400×20
20	Shaft Load - Axial	N (max.)	196N / 44 Lbf
21	Shaft Load - Radial(End of Shaft)	N (max.)	490 N / 110 Lbf
22	Weight	kg	6.2 kg / 13.6 Lb
23	Approvals	CE, cULus, RoHS	
24	Encoder Resolution & Protocol	23bit Absolute Multi-turn Nikon Protocol	
25	Encoder Type	Optical	
26	Insulation Class	F (155°C)	
27	IP rating	IP65(except shaft through hole and cable end connector)	
28	Installation Location	Indoors, free from direct sunlight, corrosive gas, inflammable gas	
29	Ambient Temperature	Operating 0 to 40°C, Storage -20 to 80°C	
30	Ambient Humidity (max.)	85% (free from condensing)	
31	Altitude (max.)	1000 m	
32	Vibration Resistance	10-150Hz 49 m/s <sup>2</sup>	
33	Rotor Poles	10	

Shaft Load: (L<sub>10</sub> life, 20,000 hours, 2,000 RPM)

### Motor Phases

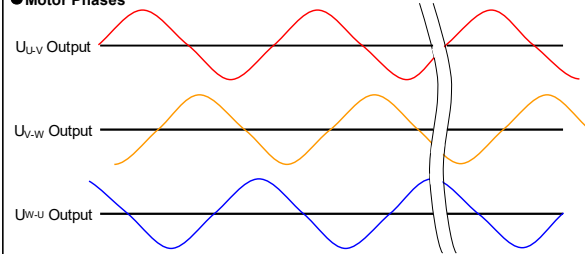

All the timing logs are obtained in CCW rotation as viewed from front shaft.

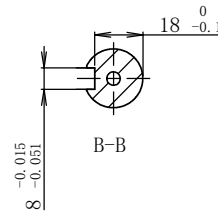
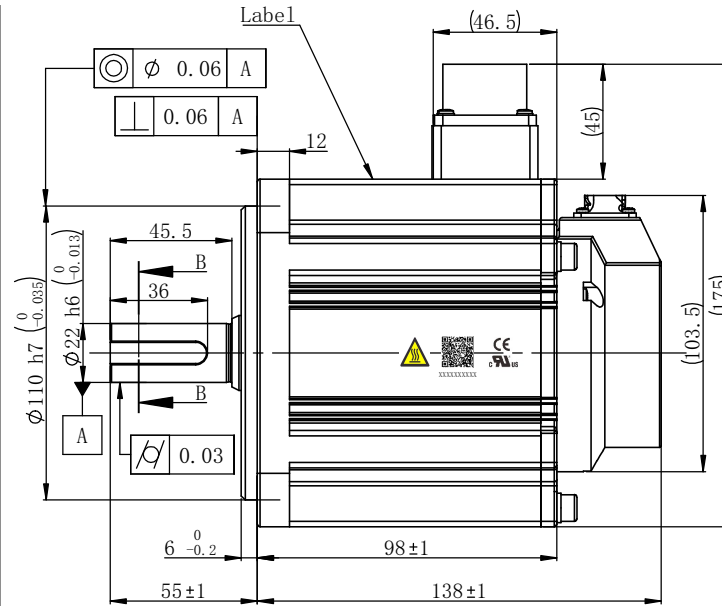
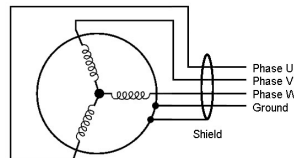

Motor Power Connector:  
XMS3102A20-18S(EUMACX)

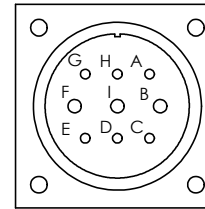

Pin#	A	B	C	D	E
Signal	GND	W	N/C	N/C	N/C
Pin#	F	G	H	I	V
Signal	U	N/C	N/C	V	

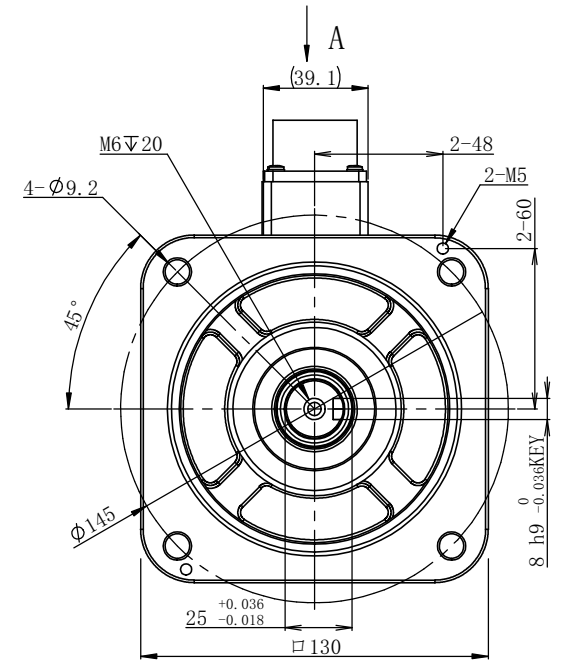

Encoder Connector:  
XM10-S10S-C(EUMACX)

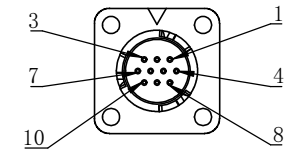

View A

Pin#	1	2	3	4	5
Signal	5V	GND	SD-	SD+	Battery+
Pin#	6	7	8	9	10
Signal	Battery-	N/C	N/C	N/C	Shield

Item Number  
S0034

### Notes:

1. A shaft seal is shipped with motor, but not installed.
2. A KEY is shipped with motor, but not installed.

Unit: mm					
First Angle Method					
Tolerances for linear and angular dimensions without individual tolerance indications	AI	△	I		2023.11.29
GB/T 1804-m eqv ISO 2768-1:m	AO			Preliminary	2023.09.08
Geometrical tolerance for features without individual tolerance indications	REV	Sign	Quantity	ECN NO.	Date
GB/T 1184-K eqv ISO 2768-2:K	Design			Technology	
UNLESS OTHERWISE SPECIFIED	Standard			Audit	
	Check			Approve	
	Marketing Dep	<input type="checkbox"/>		Date	



SM3H-132ATNUV  
4611170001546

Stage	Quality	Scale
D		1:2
Sheet		1 of 1

Shanghai AMP & MOONS' Automation Co.,Ltd