

Motor Specifications

1	Drive Input power supply		208~240VAC
2	Basic DC Bus Voltage	V (DC)	320V
3	Rated Output Power	Watts	1300
4	Rated Speed	rpm	1500
5	Max. Mechanical Speed	rpm	3000
6	Rated Torque	Nm	8.34
7	Continuous Stall Torque	Nm	9.1
8	Peak Torque	Nm	25
9	Rated Current	A (rms)	9.6
10	Continuous Stall Current	A (rms)	9.6
11	Peak Current	A (rms)	29.6
12	Voltage Constant ±10%	V(rms)/K rpm	54.2
13	Torque Constant ±10%	Nm/A(rms)	0.869
14	Winding Resistance(Line-Line)±10%	Ohm @20°C	0.66
15	Winding Inductance(Line-Line)±20%	mH	5.4
16	Inertia	kg m ²	0.00183
17	Thermal Resistance(mounted)	°C / W	0.72
18	Thermal Time Constant	Minutes	25.3 Min
19	Heat Sink Size(Iron)	mm	400×400×20
20	Shaft Load - Axial	N (max.)	343N / 77.0 Lbf
21	Shaft Load - Radial(End of Shaft)	N (max.)	683 N / 153.3Lbf
22	Weight	kg	7.3 kg / 16.1 Lb
23	Approvals	CE,cULus,RoHS	
24	Encoder Resolution & Protocol	21bit Absolute Multi-turn TMGW Protocol	
25	Encoder Type	Magnetic	
26	Insulation Class	F (155°C)	
27	IP rating	IP65(except shaft through hole and cable end connector)	
28	Installation Location	Indoors, free from direct sunlight, corrosive gas, inflammable gas	
29	Ambient Temperature	Operating 0 to 40°C, Storage -20 to 80°C	
30	Ambient Humidity (max.)	85% (free from condensing)	
31	Altitude (max.)	1000 m	
32	Vibration Resistance	10-150Hz 49 m/s ²	
33	Rotor Poles	10	

Shaft Load: (L₁₀ life, 20,000 hours, 2,000 RPM)

Motor Phases

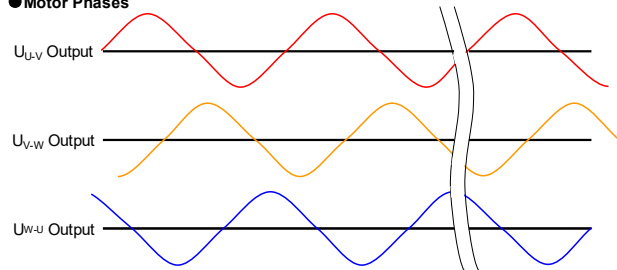

All the timing logics are obtained in CCW rotation as viewed from front shaft.

Notes:

1. A shaft seal is shipped with motor, but not installed.
2. A KEY is shipped with motor, but not installed.

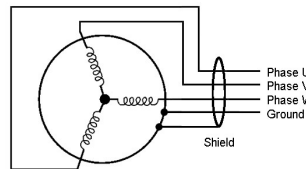
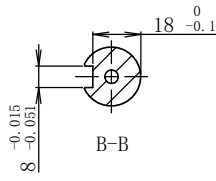
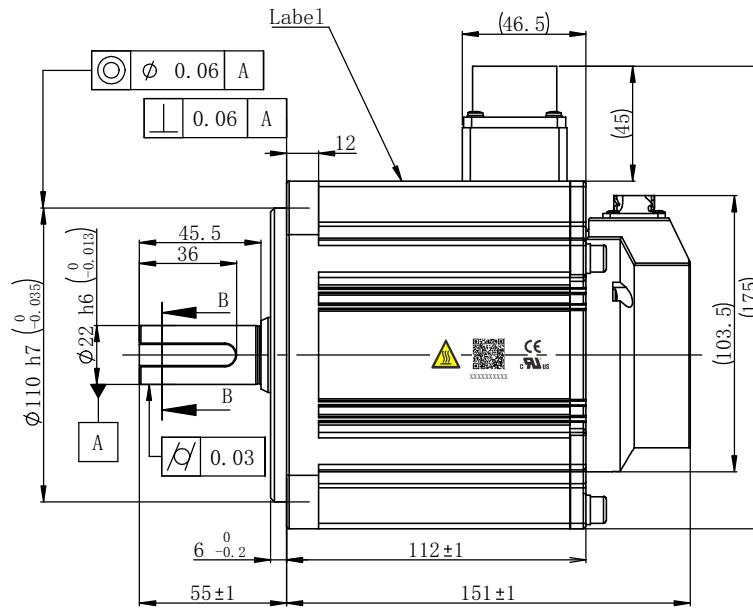

Motor Power Connector:
XMS3102A20-18S(EUMACX)

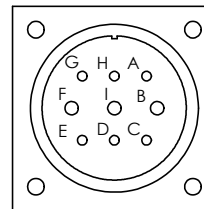

View A

Pin#	A	B	C	D	E
Signal	GND	W	N/C	N/C	N/C
Pin#	F	G	H	I	V
Signal	U	N/C	N/C	V	

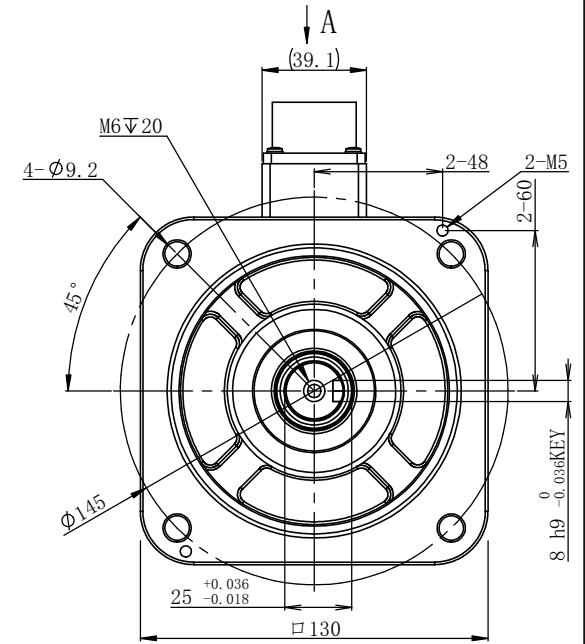

Encoder Connector:
XM10-S10S-C(EUMACX)

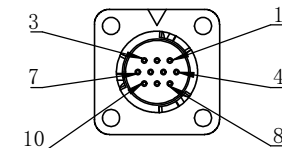

View A

Pin#	1	2	3	4	5
Signal	5V	GND	SD-	SD+	Battery+
Pin#	6	7	8	9	10
Signal	Battery-	N/C	N/C	N/C	Shield

Item Number
S0034

Unit: mm					
First Angle Method					
Tolerances for linear and angular dimensions without individual tolerance indications	AO	I		2023.11.29	
GB/T 1804-m eqv ISO 2768-1:m	REV	Sign	Quantity	Preliminary	2023.08.22
Geometrical tolerance for features without individual tolerance indications	Design			ECN NO.	Date
GB/T 1184-K eqv ISO 2768-2:K	Standard			Audit	
UNLESS OTHERWISE SPECIFIED	Check			Approve	
	Marketing Dep	<input type="checkbox"/>		Date	



SM3H-133AXNUV		
4611170001556		
Stage	Quality	Scale
D		1:2
Sheet	1 of 1	

Shanghai AMP & MOONS' Automation Co.,Ltd