

REVISIONS				
ECO NO.	REV	DESCRIPTION	DATE	APPROVED
7466	A	INITIAL RELEASE	8/30/16	J.KORDIK

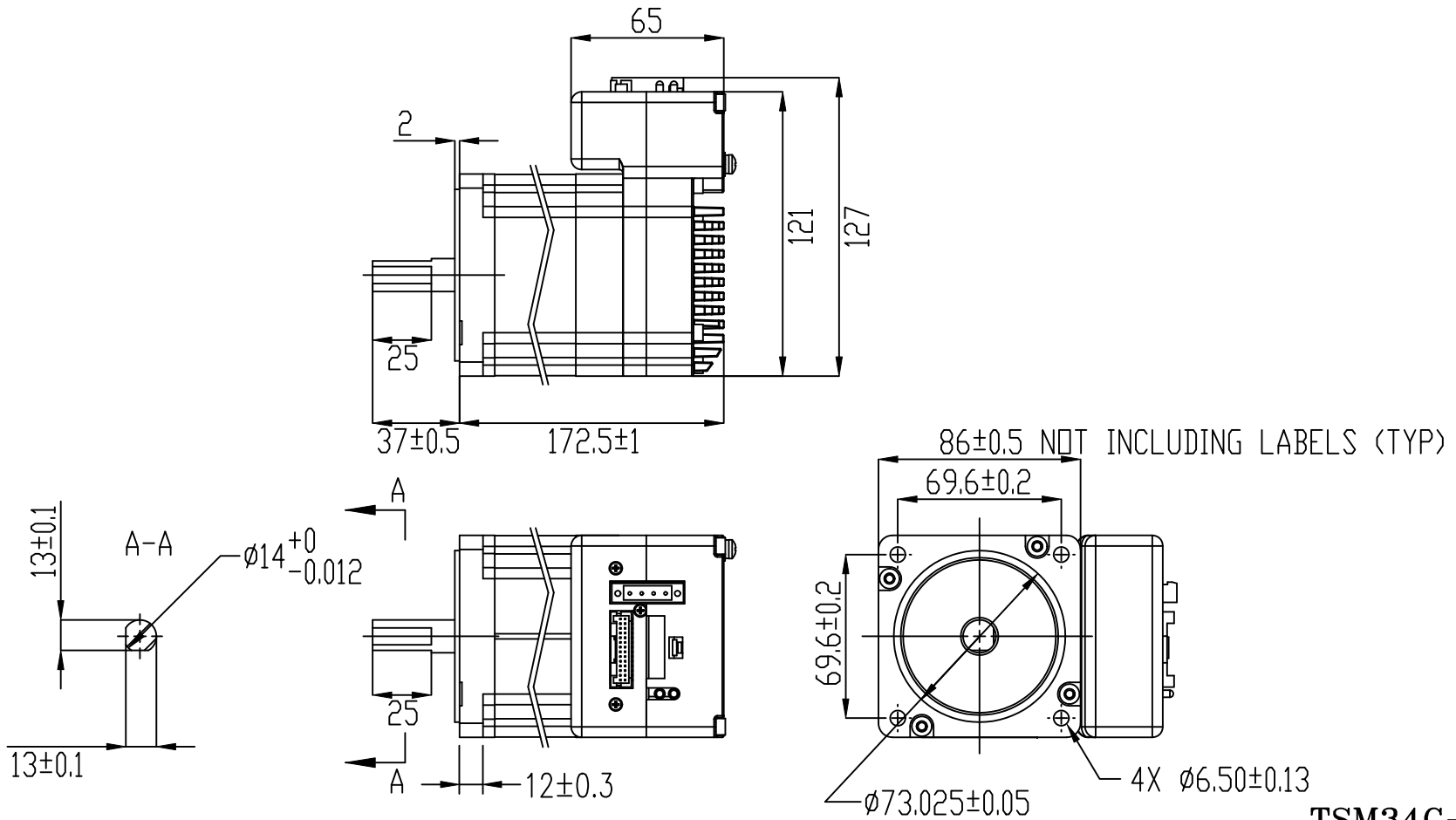

TSM34C-5CG

TOLERANCES		THIRD ANGLE PROJECTION		APPLIED MOTION PRODUCTS, INC.	
*ALL DIMENSIONS IN MM				INTEGRATED StepSERVO MOTOR OUTLINE DRAWING	
DECIMALS: MM X.XX = ±0.13 X.X = ±0.25 ANGLES: MACH. = ±0.5° CHAM. = ±5°					
COMPUTER DATA		DRAWN		B	DWG NO. TSM34C-5CG
BASE DRAWING		K.KESLER	7/13/16		
		CHECKED			A
		APPROVED		SCALE: NONE	SHEET 1 OF 1