

MCC-2 LIN

Linear Stepper Motor Controller for Two Axes



MCC-2 LIN
Linear Stepper Motor Controller
for Two Axes

TRANSLATION OF THE GERMAN ORIGINAL MANUAL

Version	Modification
5	p.44 setting in step valid from serial number 15XXXXXXXX

© 2015

All rights with:

Phytron GmbH

Industriestraße 12

82194 Gröbenzell, Deutschland

Tel.: +49 8142/503-0

Fax: +49 8142/503-190

Every possible care has been taken to ensure the accuracy of this technical manual. All information contained in this manual is correct to the best of our knowledge and belief but cannot be guaranteed. Furthermore we reserve the right to make improvements and enhancements to the manual and / or the devices described herein without prior notification. You find the updated version of this manual on the website of www.phytron.de.

We appreciate suggestions and criticisms for further improvement. Please send your comments to the following email address: doku@phytron.de

Contents

1	The MCC-2 LIN Stepper Motor Controller..	4
1.1	Overview	4
1.2	Structure of the Device.....	5
1.2.1	Stepper Motor Power Stages	6
1.2.2	Inputs and Outputs	6
1.2.3	Interfaces and Bus Mode	7
1.2.4	REMOTE/LOCAL Switch R/L.....	7
1.2.5	Reset Push-Button	7
1.2.6	Address Switch.....	8
1.2.7	Status LED	8
1.3	Block Diagram	8
1.4	Extent of Supply	9
1.5	Operator Panel	10
1.6	Directives and Standards	11
1.7	Declaration of Incorporation	12
2	To Consider Before Installation	13
2.1	Qualified Personnel	13
2.2	Safety Instructions.....	14
2.3	Ambient Conditions	15
3	Protective Measure Options	16
4	Design Requirements.....	18
4.1	Electromagnetic Compatibility (EMC)..	18
4.1.1	Remarks	18
4.1.2	EMC Measures.....	18
4.2	Cables	20
5	Technical Data	21
5.1	Mechanical Data.....	21
5.2	Electrical Data	22
6	Installation	23
6.1	Mechanical Installation	23
6.2	Electrical Installation.....	25
6.3	Connection of the Power Supply	25
6.3.1	Controller and Motor at X4	25
6.3.2	24 V at X9.....	26
6.4	X7/X8 Motor Connector.....	27
6.4.1	Stepper Motor Connection	27
6.4.2	Wiring Schemes for 2-Phase Stepper Motors	28
6.4.3	Motor Cable.....	29
6.5	X5 Interface Connection.....	30
6.5.1	USB Interface	31
6.5.2	Ethernet Interface.....	32
6.5.3	RS 485 Interface	33
6.5.4	RS 232 Interface	35
6.6	Signal Interface Connection	36
6.6.1	X1 AD Converter	36
6.6.2	X2 Limit Switch Input.....	37
6.6.3	X3 Digital Inputs/Outputs.....	37
6.6.4	X6 Encoder Connector.....	39
6.6.5	X10 Enable Connector	41
7	Putting into Service and Test	43
7.1	Test the Communication between Controller and PC	43
7.2	Test Stepper Motor(s), I/Os and Limit Switches.....	44
8	Programming.....	46
8.1	LabVIEW®	46
8.2	MiniLog.....	46
9	Temperature and Ventilation.....	47
10	Warranty, Trade Marks and Protective Measures	48
10.1	Warranty.....	48
10.2	Trade Marks	48
10.3	ESD Protective Measures	48
11	Index	49

1 The MCC-2 LIN Stepper Motor Controller

1.1 Overview

The MCC-2 is a user-friendly and compact linear stepper motor controller from the MCC motion controller series. The MCC-2 can drive two phase stepper motors linearly with motor currents of 1.7 A_{PEAK} at 24 V and of 0.85 A_{PEAK} at 48 V.

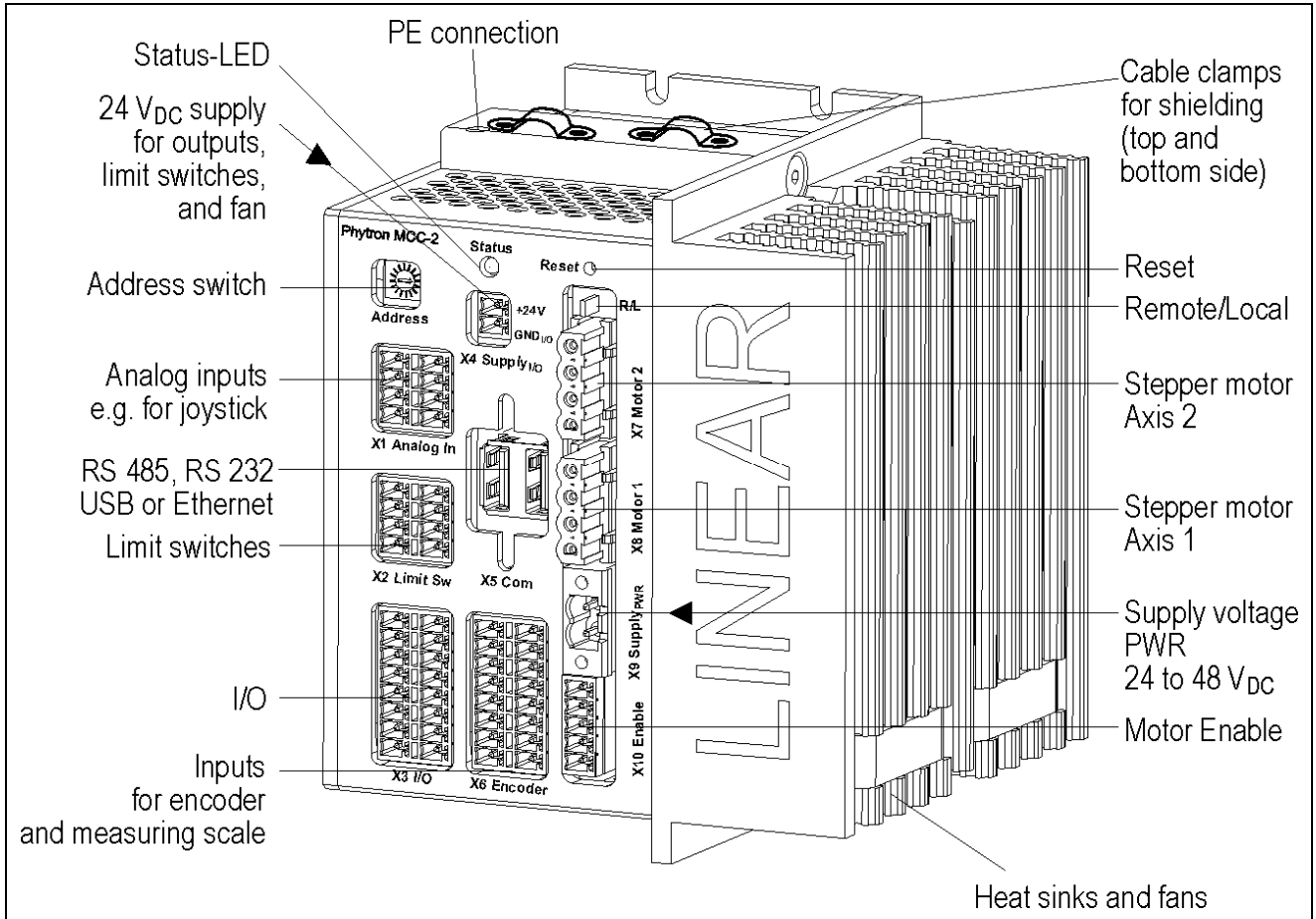

Fig. 1: Front view

The MCC-2 can control stepper motors with low noise voltage. So it's qualified for extremely application (e.g. measuring application), where sensitive measures could be influenced by noise voltage. The complete linear design of the MCC-2 minimizes the EMC disturbances.

Machine sequence controls can be programmed on PC by the MiniLog-Comm communication software.

MCC-2 and stepper motors need a DC power supply from 24 to 48 V_{DC}. 24 V_{DC} is recommended.

A separate 24 V_{DC} supply voltage is required for the outputs and limit switches.

The heat sink contains two fans, which are supplied via X4 with +24 V_{DC}.

The MCC-2 housing contains mounting brackets for different mounting positions. A clip for rail mounting is mounted on the rear side.

1.2 Structure of the Device

The figure below shows the layout of the connectors on the MCC-2 front side.

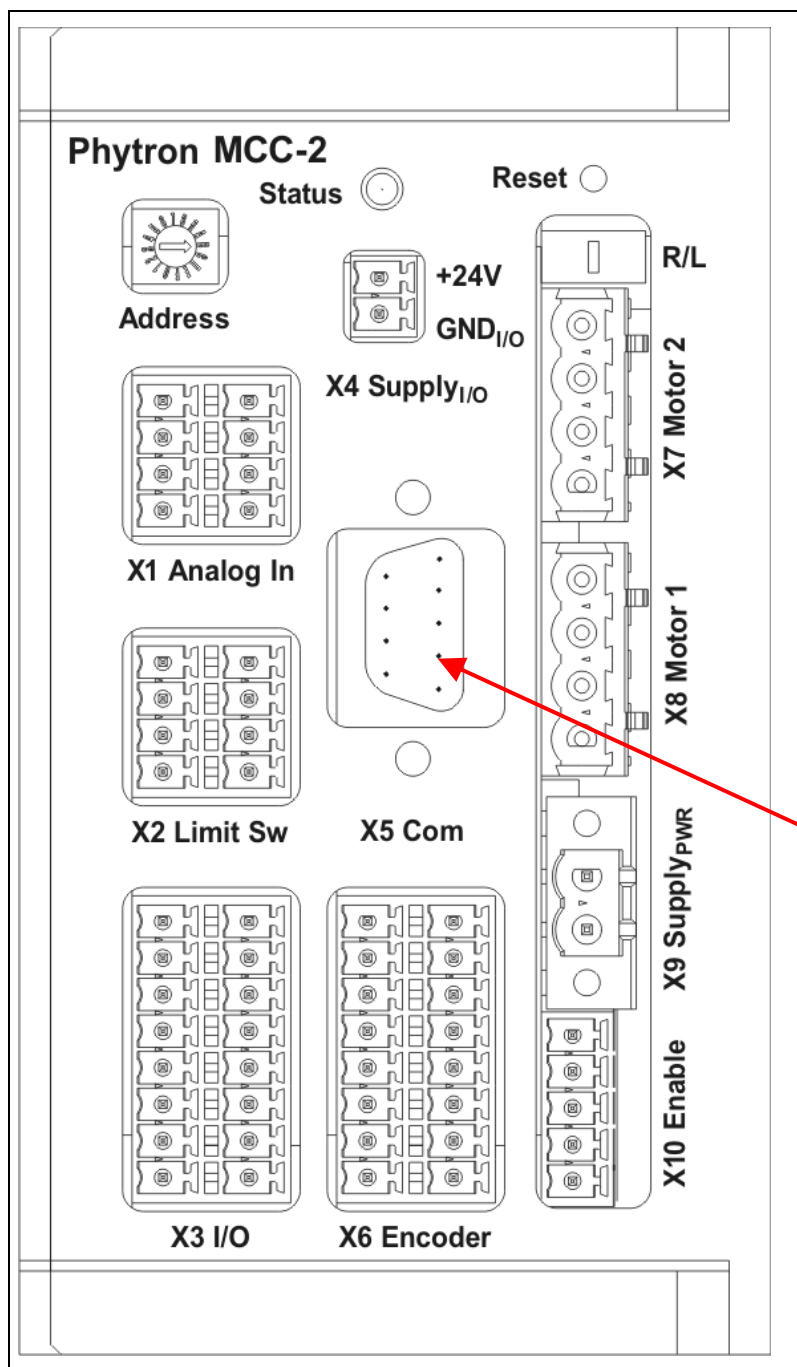

See table:
Overview of connectors

X5 Com: There are different connectors dependent on the built-in PC interface card!

Fig. 2: Connector's layout

Please mention for all connector figures in this manual:

When the controller is placed in such position that the MCC-2 designation is at the left upper edge, the upper pin in the drawing also is the upper pin at the device.

1.2.1 Stepper Motor Power Stages

A power stage is built-in for each axis for linear control of the two-phase stepper motor.

For smooth stepper motor movement, the power stages solve the motor full step into increments up to 1/256 step.

Run current, stop current and Boost current (acceleration) can be programmed independently up to 1.7 A_{PEAK} at 48 V_{DC} supply voltage.

The following errors will switch off the power stage:

- Short circuit: between phase and power supply
 between both motor phases
 within a motor phase
 against ground
- Over temperature
- Under voltage: e. g. if the voltage drops due to a weak power supply and
 dynamic motor movements

1.2.2 Inputs and Outputs

MCC-2 can be regarded as independent machine controller because of eight digital inputs, which are electrically separated from the sequential controller, and eight overload-safe outputs.

Two signal inputs of each axis can be used for connecting type pnp-NCC (default) or pnp-NOC limit switches.

A joystick can be connected to the analog input X1.

Additional safety requirement was considered during development, because the MCC-2 was designed for applications in the domain of medical devices:

The motors can be activated by the Enable input – independent of the incoming control pulse signals (X10).

The encoder inputs for step failure monitoring allow the interpretation of the encoder signals. Incremental encoder or absolute encoder acc. to SSI-standard can be connected to the same connector (X6).

1.2.3 Interfaces and Bus Mode

The X5 Com communication interface is available with USB-, RS 485(4-wire) or RS 232-layout. The following possibilities are accessible by interface:

- Controller and motor parameter programming
- Controller configuration by software
- Online diagnostics for safe operation and easy maintenance
- Test mode and status information
- Firmware update
- Controller communication via Ethernet

The MCC-2 can be programmed user-friendly by MiniLog-Comm for Windows (see manual MiniLog-Comm).

1.2.4 REMOTE/LOCAL Switch R/L

You can select the controller's operating mode with the REMOTE/LOCAL switch:

REMOTE: The controller is connected to the PC via interface. In this operating mode, programs edited by the customer can be transmitted from PC to controller and back. In the REMOTE mode it is also possible to test single instructions or to test the motor run using the MiniLog-Comm communication software.

LOCAL: When switching to LOCAL the stored program will be started. The program should be stored in the auto start register.

- a) The program runs **without** connection to the PC.
- b) Program run **with** connection to an external computer:
The PC can be called by the sequential program in order to exchange actual data.

1.2.5 Reset Push-Button

The Reset push-button above the REMOTE/LOCAL switch is mounted recessed in order to inhibit accidental operation.

Reset cancels possibly error messages.

Delay time after end of Reset signal: about 3 sec.

1.2.6 Address Switch

The logic device address can be selected by the address switch and set from 0...F. This rotary switch is only read after power on or after a reset, i.e. later changes remain without effect during the regular operation.

1.2.7 Status LED

The two-color LED shows the status of the device:

- green = ready, no error
- red = Error (see status window in the MiniLog-Comm software)
- orange = Busy (update of the indexer firmware)

1.3 Block Diagram

This block diagram shows a simplified layout. You'll find details, e. g. pin assignments in the corresponding chapters.

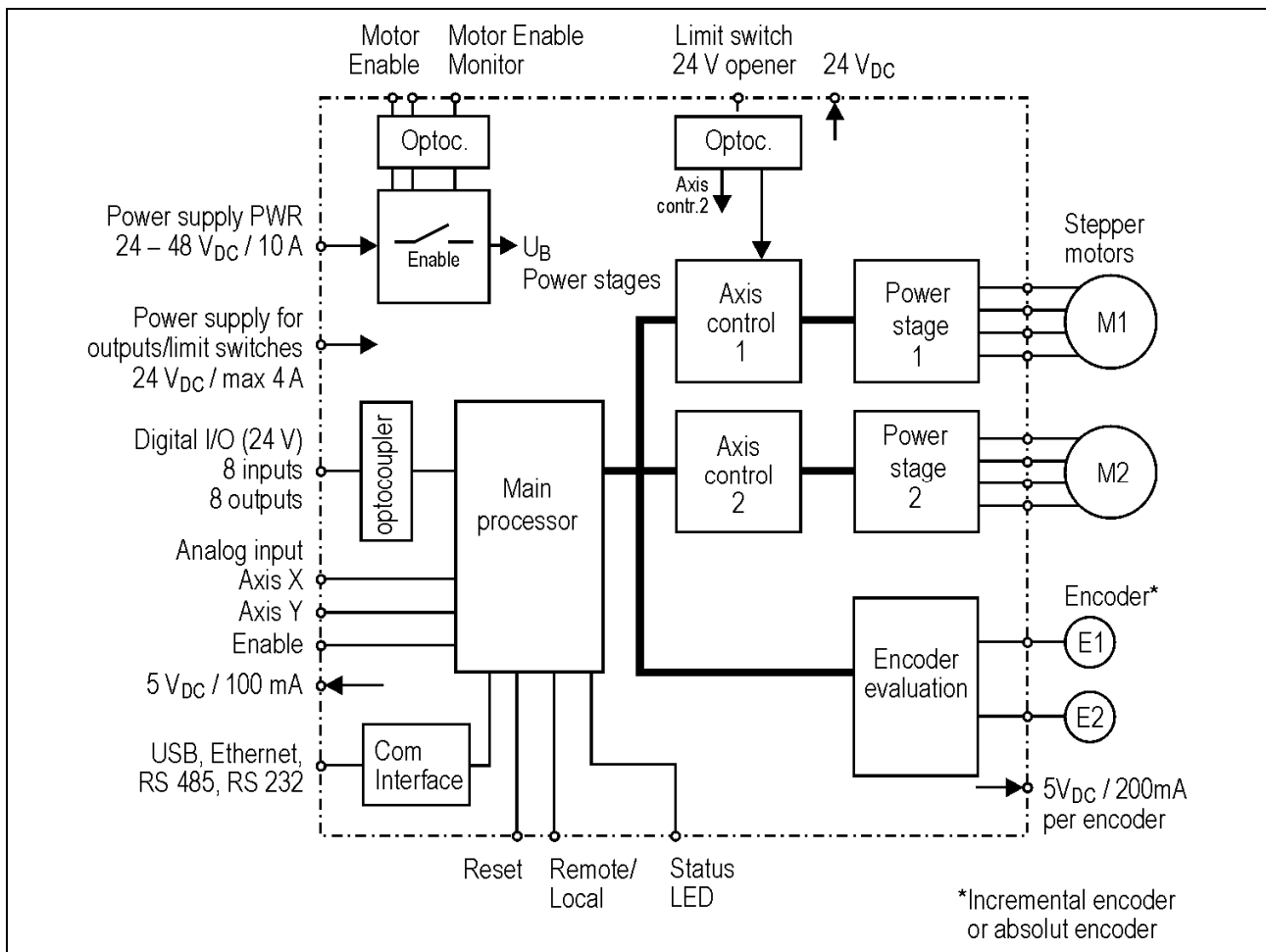

Fig. 3: Block diagram of MCC-2 LIN

1.4 Extent of Supply

The MCC-2 is available in the following **options** (#: Ident number):

- MCC-2 Motion-Controller with mating connector kit

with USB interface for wall mounting (W)	#10008454
with USB interface for rail mounting (H)	#10008455
with RS 485 interface for wall mounting	#10008452
with RS 485 interface for rail mounting	#10008453
with RS 232 interface for wall mounting	#10008449
with RS 232 interface for rail mounting	#10008451
with RS 232 interface for wall mounting with RS 232 adaptor	#1000XXX
with USB converter for wall mounting (cable A-A 20 cm included)	#10008456
with USB converter for rail mounting (cable A-A 20 cm included)	#10008457
with Ethernet connection for wall mounting	#10012345
with Ethernet connection for rail mounting	#10012344

Included in delivery:

- MCC-2 Manual
- MiniLog Programming Manual
- MiniLog-Comm Manual
- Phytron CD with MiniLog-Comm software

Supplementary Parts

- Rail mounting kit #02005659
- Mating connector kit (X1 to X4, X6 to X10) #10005871
- Cable (connection A-A) 20 cm #10006857
- Cable (connection A-A) 100 cm #10006880
- USB cable (connection A-B) 200 cm #10006881
- USB-485 converter stick #10012292
- Power supply unit PS 5-48 (5 A, 48 V) for wall mounting #10006780
- Power supply unit PS 5-48 (5 A, 48 V) for rail mounting #10006148
- Power supply unit PS 10-24 (10 A, 24 V) for wall mounting #10006781
- Power supply unit PS 10-24 (10 A, 24 V) for rail mounting #10006578

1.5 Operator Panel

A MCC-2 with RS 232 adaptor is used for operator panel connection (e.g. BT 5). The terminal is connected to the RS 232 connector of the adaptor (Fig. 4).

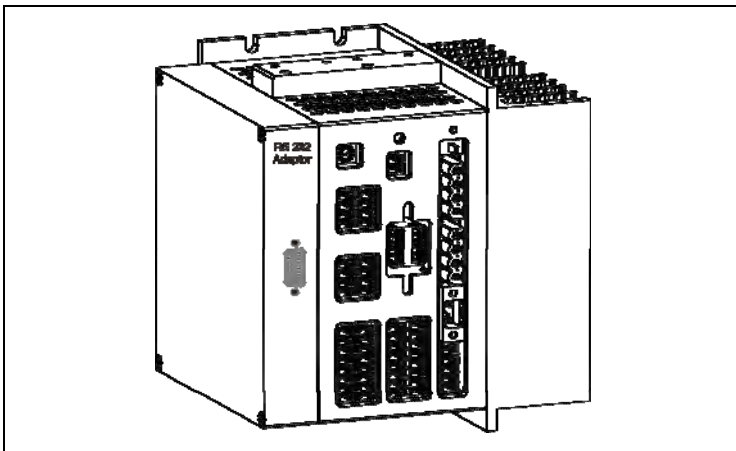

Fig. 4: MCC-2 with RS 232 adaptor

Then, enabled functions can be used by the operator personnel without PC: for example: selection of another program or change of the piece numbers, length, or the like.

The operator panel can display textual data or error messages on demand. The function keys on the operator panel are labeled individually and defined by the controller's programmer.

More functions can be added in the expert mode like input of drive instructions, setting of outputs or display of status messages.

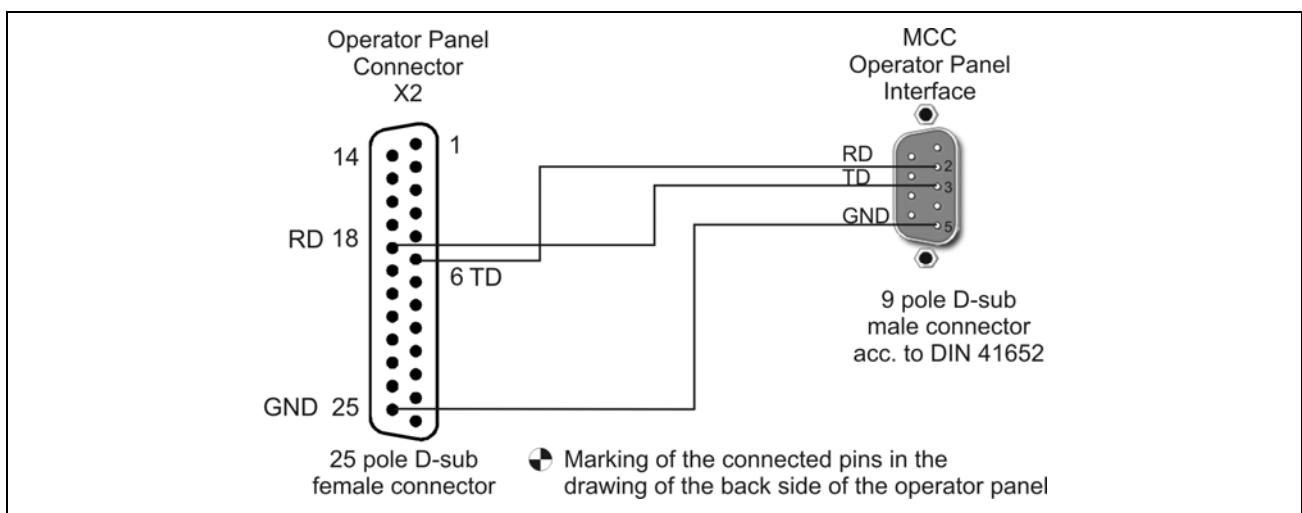

Fig. 5: MCC-2 cable → BT 5



The MCC-2's baud rate should be scaled down to 38 400 for using the operator panel.

You'll find the description of the operator panel in Phytron's manual 'Operator Panel BT 5'.

1.6 Directives and Standards

CE Mark	With the declaration of conformity and the CE Mark on the product the manufacturer certifies that the product complies with the requirements of the relevant EC directives. The unit, described here, can be used anywhere in the world.
EC Machine Directive	The drive system, described here, isn't a machine in the sense of the EC machine directive (2006/42/EC), but a component of a machine for installation. They have no functional moving parts. But they can be part of a machine or equipment. The conformity of the complete system in accordance with the machine guideline is to be certified by the manufacturer with the CE marking.
EC EMC Directive	The EC Directives on electromagnetic compatibility (89/336/EEC) applies to products, which can cause electromagnetic interference or whose operation can be impaired by such interference. The controller's compliance with the EMC Directive cannot be assessed until it has been installed into a machine or installation. The instructions provided in "Installation" must be complied with to guarantee that the MCC-2 is EMC compliant when fitted in the machine or installation and before use of the device is permitted.
Standards for safe operation	EN 60204-1: 1998-11: Electrical equipment of machines, degree of pollution 2 must be observed EN 60529: IP Degree of protection
Standards for observing the EMC limit values	EN 61000-3-2: EMC EN 61000-6-1, 3, 4: Emission standard EN 61000-6-2:2005: EMC Immunity for industrial environments
Standards for measuring methods of observing EMC limit values	EN 55011 class B: Noise field and voltage measuring EN 61000-4-2...6,11: Emission standard test

1.7 Declaration of Incorporation



Declaration of Incorporation according to EC directive 2006/42/EC on machinery (Annex II B) for partly completed machinery

Name and address of the manufacturer:

Phytron-Elektronik GmbH,
Industriestr. 12
82194 Gröbenzell

Representative in EU, authorized to compile the relevant technical documentation:

Rainer Gareis
Phytron-Elektronik GmbH,
Industriestr. 12
82194 Gröbenzell

Description of the partly completed machinery:

Product denomination: Programmable Stepper Motor Controller for one or two Axis
Model/Type: MCC-1, MCC-2 und MCC-LIN

From serial number 1001xxxxx

We declare that the product complies with the following essential requirements of the Machinery Directive 2006/42/EC:

1.1.2.; 1.1.5.; 1.3.1.; 1.3.4.; 1.5.1.; 1.5.2.; 1.5.4.; 1.5.5.; 1.5.6.; 1.5.16.; 1.6.3.; 1.6.4.; 1.7.2.; 1.7.3.; 1.7.4.

In addition the partly completed machinery is in conformity with the following EC Directives:

EC Directives 2004/108/EC relating to electromagnetic compatibility.

We declare that the relevant technical documentation is compiled in accordance with part B of Annex VII.

We commit to transmit, in response to a reasoned request by the market surveillance authorities, relevant documents on the partly completed machinery.

Important note! The partly completed machinery must not be put into service until the final machinery into which it is to be incorporated has been declared in conformity with the provisions of Directive 2006/42/EC on Machinery, where appropriate, and until the EC Declaration of Conformity according to Annex II A is issued.

Gröbenzell, 2010-02-24



Johannes Schmid
Technical Director

AP QS-0670-4
CE 7002 Rev. 1

Phytron-Elektronik GmbH
Industriestr. 12 - 82194 Gröbenzell
Postfach 1255 - 82180 Gröbenzell
T +49-8142-503-0 F +49-8142-503-190
E info@phytron.de W www.phytron.de

Geschäftsführung Birgit Hartmann
Reg.-Gericht München - HRB 44 426
USt-Ident-Nr DE 128 242 222
Steuernummer 117-135-10027

Genossenschaftsbank - Kto 96610 - BLZ 70169464
IBAN DE 6770 1694 6400 0009 6610 - BIC GENODEF1M07
Sparkasse Fürstenfeldbruck - Kto. 1801265 - BLZ 70053070
Oberbank München - Kto. 1041021021 - BLZ 70120700
Volksbank Fürstenfeldbruck - Kto. 712531 - BLZ 70163370
Postbank München - Kto 0286001800 - BLZ 70010080

2 To Consider Before Installation



Read this manual very carefully before installing and operating the MCC-2. Observe the safety instructions in the following chapter!

2.1 Qualified Personnel

Design, installation and operation of systems using the MCC-2 may only be performed by qualified and trained personnel.

These persons should be able to recognize and handle risks emerging from electrical, mechanical or electronic system parts.

The qualified personnel must know the content of this manual and be able to understand all documents belonging to the product. Safety instructions are to be planned.

The trained personnel must know all valid standards, regulations and rules for the accident prevention, which are necessary for working with the product.



WARNING

Without proper training and qualifications damages to devices and injury might result!

2.2 Safety Instructions

i The MCC-2 is designed for operating as a wall or rail mounting device. An installation is only allowed, if the requirement of the EC Machine Directive and EMC are conformed with. See chap. 1.6.

i This product is used as a part of a complete system, therefore risk evaluations must be made before the use of the product regarding the concrete application. According to the results safety measures have to be taken and verified.

Personnel safety must be ensured by the concept of this complete system (e.g. machine concept).



WARNING

Injury or damage by overvoltage!

The MCC-2 must only be operated in accordance with the protective measures in chap. 3.



CAUTION

Risk of damage by false motor current setting!

In case of motor voltages > 24 V:

The controller must only be operated if the unit and the motor housing both are connected to protective ground.



CAUTION

Risk of damage by not fixed cables!

Motor cables and motor supply cables should be fixed to the device by the cable clamps at the front side.



DANGER

Danger of electric shock!

Be careful handling the screw connectors X7/X8.

As long as the power stage is connected to supply voltage, a hazardous voltage level is present at these components, even if the motor is not wired. Up to 3 minutes after turning off the supply voltage, dangerous voltages may still exist at the connectors.

The instrument setting (e. g. motor current) must **only** be done while separated from the power supply with a special instrument.



DANGER

Danger of electric arching!

Always switch off the supply voltage before connecting or disconnecting any wires or connectors at the MCC-2.

Do not unplug the connector while powered!



Please consider when connecting the X10 Enable connector:
Both Enable inputs must be wired for activation!



DANGER

Danger of touch voltage!

To avoid dangerous touch voltages, all voltages should be safely separated from the mains. The maximum voltage limits are the specified values of the corresponding chapters.



WARNING

Danger of injury if touching the surface!

The surface of the MCC-2 reaches temperatures more than 75 °C during operation.

The controller has to be deactivated at temperatures more than 75 °C.

2.3 Ambient Conditions

Installation	wall or rail mounting
Permissible ambient temperature	operation: 5 to 50 °C storage: -10 to +60 °C transport: -10 to +60 °C
Permissible heat sink temperature	max. 75 °C heating curve see chap. 9
Relative humidity	ambient conditions: class 3K3 acc. to EN 60721-3-3:1995: 5% ... 85%, no condensation permissible
Degree of pollution	stage 2
Device protection	degree of protection acc. to DIN EN 60529:1991 IP 20

3 Protective Measure Options

The control unit must be operated by the protective measure PELV acc. to VDE 0100. Board and motor housing have to be grounded and/or connected to 0 V.

Various options are possible to achieve the protective measure PELV:

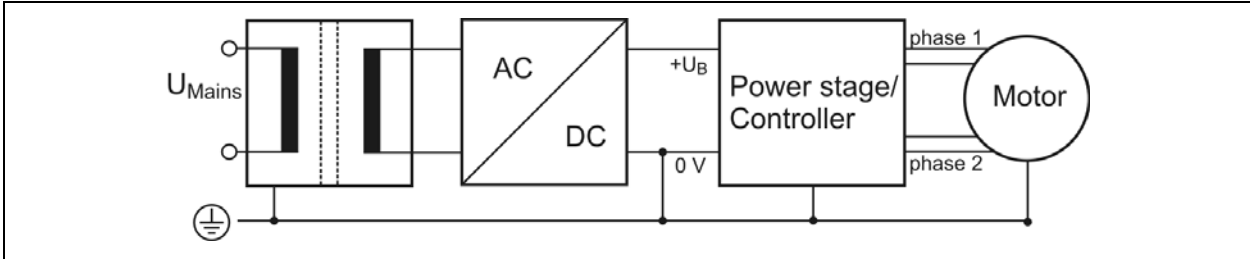

Fig. 6: PELV – Grounding: total

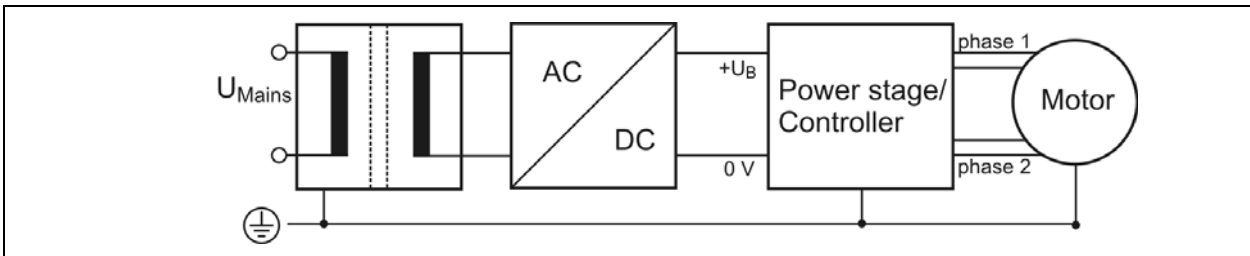

Fig. 7: PELV – Grounding: Power Stage and Motor.
The secondary winding of the transformer (SELV supply) must not be grounded because the equipment is grounded.

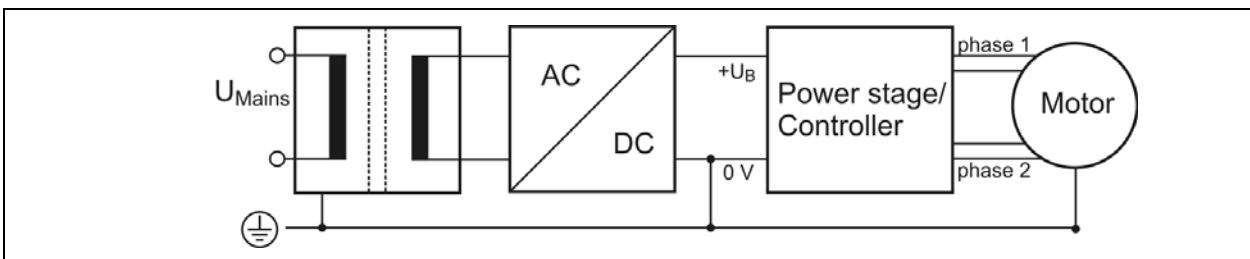

Fig. 8: PELV – Grounding: 0 V and Motor

If there is no PE clamp on the motor, the 0 V wire **must** be grounded to complete the protective measure PELV (Fig. 9 and Fig. 10):

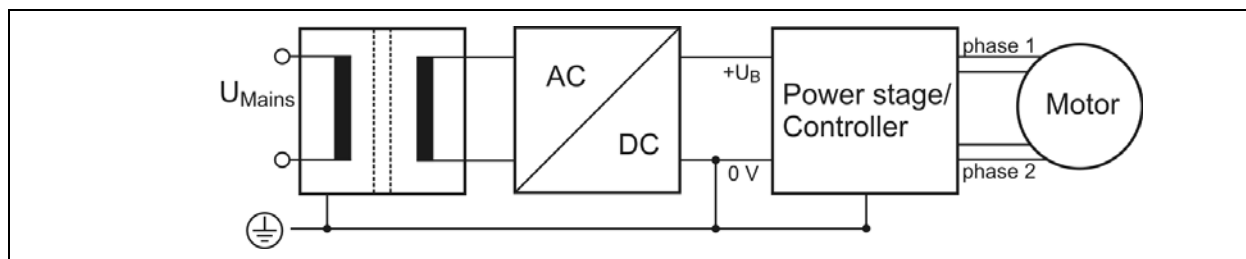

Fig. 9: PELV – Erdung: 0 V and Controller

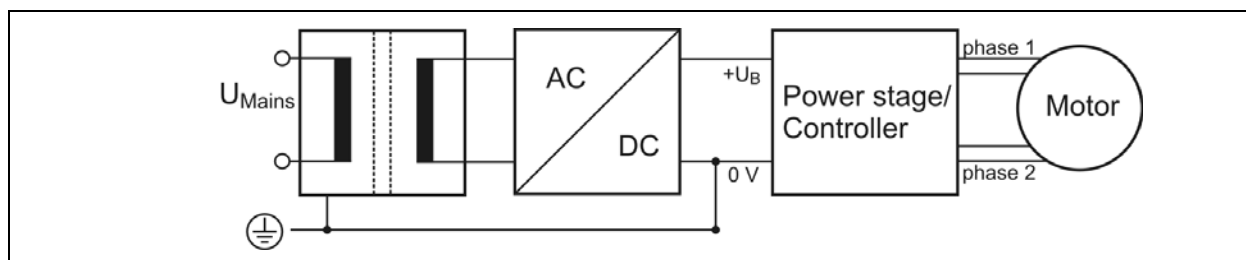

Fig. 10: PELV – Grounding: 0 V



Protective measure PELV for application of the $+U_B$ should not exceed $70 V_{DC}$ or $50 V_{AC}$ at dry environment (environmental conditions 3 acc. to IEC 61201). It is essential for MCC: $+U_B \leq 48 V_{DC}$.

The supply transformer must be constructed with reinforced or double insulation between supply and secondary winding (acc. to EN 61558).

Only use motors which are checked acc. to EN 60034-1 (500 V_{AC} /1 minute).

4 Design Requirements

4.1 Electromagnetic Compatibility (EMC)

4.1.1 Remarks

	Risk of injury by interference of signals and devices!
	<p>Perturbed signals can cause equipment to react unexpectedly.</p> <ul style="list-style-type: none"> • Connect the controller to the EMC requirements. • In electrically noisy environments ensure the correct execution of the EMC measures. Disregarding these precautions can cause death, serious injuries or material damages.

4.1.2 EMC Measures

	EMC Measures	Effect
Device Mounting	Use cable clamps for shielding, connect metallic parts at a large area.	Good conductivity due to planar contacts.
	Connect the housing via cable diameter more than 2 mm ² with potential equalisation.	Reduction of mutual interference.
	Fit switching devices such as contactors, relays or solenoids with interference or spark suppressors (e. g. diodes, varistors, RC elements).	
Cabling	Keep cables as short as possible. No "safety loops".	Avoidance of capacitive and inductive interference
	Connect the shielding of all shielded cables to the housing by the cable clamps to a large area.	Reduction of EMC emissions.
	Lay the cables spatially separated from each other (distance at least 20 cm): <ul style="list-style-type: none"> • signal and power cables • power and master cables • line filter input and output cable 	Avoidance of mutual interference

	Ground a large surface area of the shieldings of digital signal cables.	Stray interference on control cables, reduction of emissions.
Power Supply	Protective circuit to mitigate over voltage or lightning strikes.	Protection of damage by over voltage.

<p>Preset for EMC: Motor cable</p> <p>The motor cable is a source of interference and must be carefully laid.</p> <p>Use the cables recommended by phytron. They are tested for EMC safety and are suitable for movement.</p> <p>The motor and the encoder cable of the driving system must be connected to a large surface area of the output of the control cabinet and the motor with a low resistance.</p> <ul style="list-style-type: none"> • The PE lead (green/yellow) of the motor cable should be fixed at the earthing screw below the MCC-2 motor connector. • The PE lead at the motor side of the cable should be fixed at the motor's earthing screw. • For EMC compliant wiring it is important to conductively connect the motor cable shielding mesh with the controller housing. Use the cable clamps at the bottom and the top side of the MCC-2. Remove the external cable sheath in that range of the cable where you fix it with one of the cable clamps. • The cables connecting motor and controller should not be interrupted (e.g. by connectors). • At the motor side the cable's shielding mesh should be connected to the motor housing at a large area. We recommend to use special EMC type conduit fittings. • In case of motors without adapted conduit fittings the cable shielding must be connected as near to the motor as possible and has to be applied to PE.
<p>Potential equalization cables</p> <p>Connect the shielding on all sides for protection from interference.</p> <p>The difference of potential can cause incorrect currents on the shielding and must be avoided by potential equalization cables.</p>

4.2 Cables

Overview :

	maximum cable length [m]	minimum cross section [mm ²]	shielded, grounded on all sides
Motor cable	The length depends on the cable resistance: $R_{\text{cable}} < 0.2 \times R_{\text{phase}}$	Dependent on the maximum current of the motor and the motor cable length is suitable:	
	25	0.1 per 1 Ampere motor current	X
	50	0.2 per 1 Ampere motor current	X
USB	5	—	X
Signal line (digital)	100	0.14	X

5 Technical Data

5.1 Mechanical Data

Device protection	IP 20
Dimensions WxHxD	108x127x110 (mm)
Weight with heat sink	about 1350 g
Mounting	The MCC-2 housing is constructed with mounting brackets at two side panels. We recommend a vertical mounting (labeling readable) because of a better heat dissipation. The clip for rail mounting is mounted on the rear side.
Accessories (optional)	MCC-2 with additional RS 232 port for connecting a BT 5 operator panel MCC-2 with attached USB converter

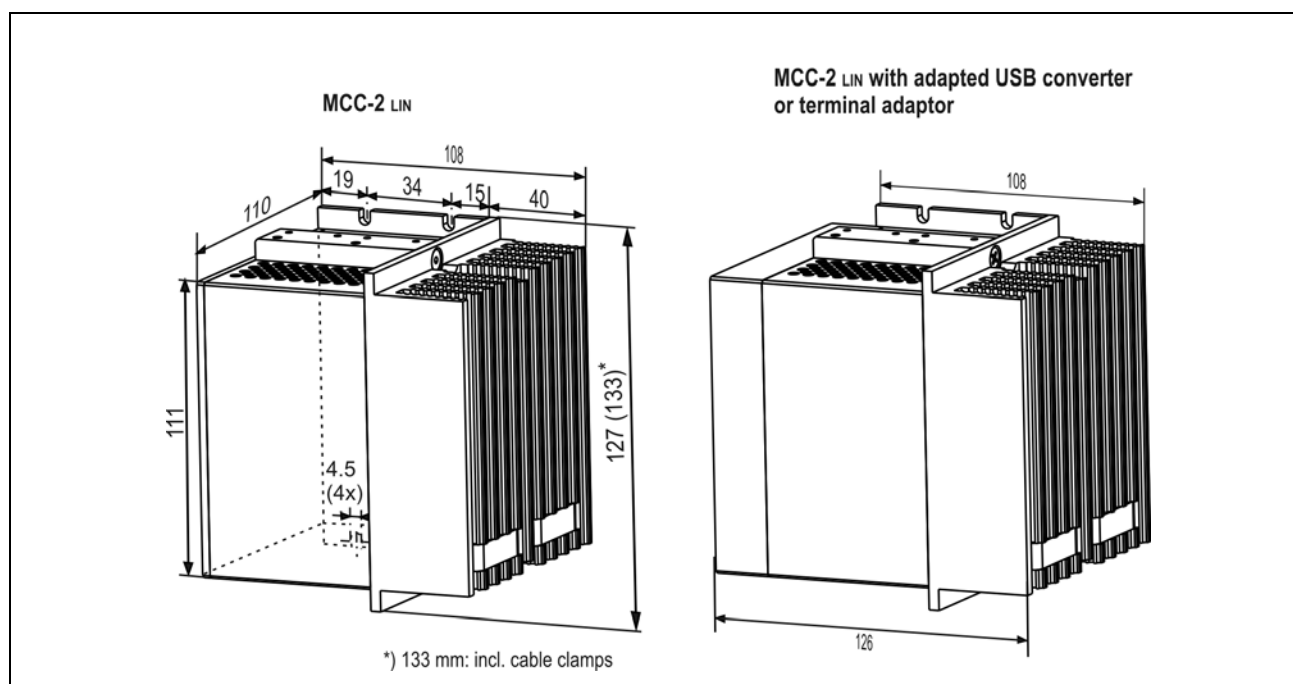

Fig. 11: Dimensions in mm

Wall mounting: screws type M4 or UNC 6-32

Required space at the front side: about 35 mm for connectors and cables

5.2 Electrical Data

Technical Characteristics	
Supply voltage	<p>Unregulated filtered DC voltage</p> <p>Admissible voltage range for</p> <ul style="list-style-type: none"> • Controller and motor: 24 to 48 V_{DC} (X9) nominal voltage: 24 V_{DC} (recommended) • Limit switch and outputs: 24 V_{DC} (X4) <p>Reinforced or double insulation between mains and secondary circuit is required.</p>
Stepper motor	<p>Two-phase stepper motors in 4, 6 or 8 lead wiring scheme at X7/X8</p> <p>Winding resistance between 0.1 and 10 Ohm</p> <p>Winding inductance 0.5 to 10 mH per phase</p>
Phase current	<p>up to 1.7 A_{Peak}</p> <p>max. phase current at 24 V_{DC}: 1.2 A_{r.m.s.} (nominal current) at 48 V_{DC}: 0.6 A_{r.m.s.}</p>
Step resolution	1/1 to 1/256 of a full step
Max. run frequency	40 kHz for full step, 20 kHz for half step
Interfaces	RS 485, RS 232 or USB (X5)
Connectors	<p>2 analog inputs (X1)</p> <p>2 limit switch inputs (X2)</p> <p>8 digital inputs / 8 digital outputs (X3)</p> <p>1 encoder per axis (incremental or SSI) (X6)</p>
Fuse	6.3 A fast
Ambient temperature	<p>Operation: 5 to 50 °C</p> <p>Storage: -10 to 60 °C</p> <p>Transport: -10 to 60 °C</p>
Max. heat sink temperature	75 °C
Temperature behaviour	see chap.9
Ventilation	<p>Fan (SUNON type GM1235PFV2-8), mounted in the heat sink, internal supply voltage with 24 V_{DC} via X4</p> <p>Automatic activation of the fan at about 48 °C</p>
Error detection	<p>The MCC shuts down in case of under voltage 17 V ±1 V. The error is set by the status bit and is indicated by the status LED which can be reset by a hardware or software reset (power stage reset).</p> <p>The power stage is deactivated in case of an error.</p>

6 Installation

6.1 Mechanical Installation

	<p>DANGER Danger of electric shock in case of foreign particles or damage!</p>
	<p>Make sure during the installation that not fixed particles, such as pieces of wire or assembly parts, can fall into the device. Conductive foreign materials in the product can endanger persons in case of parasitic voltage and destroy the device by short circuit.</p>

Rail or Wall Mounting

- The controller should be vertically mounted.
- Mount the controller to a plane surface with appropriate load capacity.
- The wall mounting brackets on two sides of the device allow different mounting positions.
- The rail mounting clip is fixed with screws on the rear side.
- The rap holes can also be used for individual mounting solutions on the rear side.



The mounting screws used must intrude not more than 1 mm into the device's inner parts (housing thickness: 4mm).

- Minimum free space above and below the controller: 100 mm
 Keep the air slots free to allow convective air exchange.
- Minimum free space to other devices besides the controller: 30 mm
- Recommended free space before the controller for connectors and cables: about 35 mm.
- The heated air flow from other devices and components doesn't result in excessive heating of the cooling air.
- The controller has to be mounted and operated at a place free of shocks and vibrations.

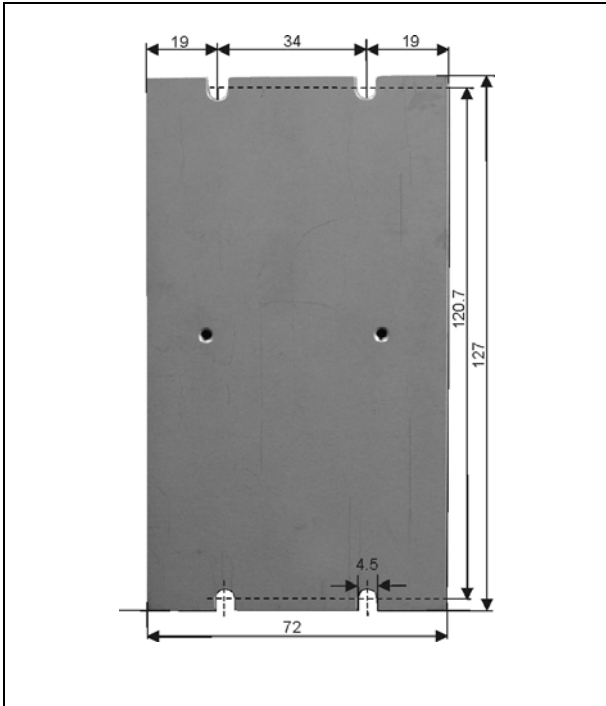

Fig. 12: Wall mounting, dimensions

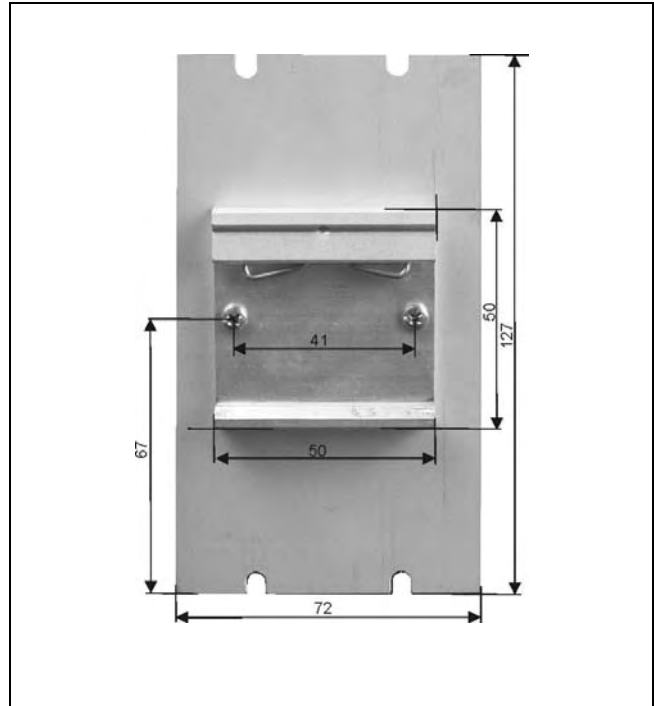

Fig. 13: Rail mounting, dimensions

6.2 Electrical Installation

Connectors - Overview

Connector	Number of poles	Phoenix connector type	Phoenix mating connectors	Material number (mating connector)
X1: AD converter X2: Limit switch	2 x 4	MCDN 1,5/4-G1-3,5 P26THR	FMC 1,5/4-ST-3,5	#10005880
X3: I/O X6: Encoder	2 x 8	MCDN 1,5/8-G1-3,5 P26THR	FMC 1,5/8-ST-3,5	#10005881
X4: Supply I/O	2	MC 1,5/2-G-3,5 THT	FMC 1,5/2-ST-3,5	#10007077
X7 / X8: Motor	4	IC 2,5/4-G-5,08	IC 2,5/4-ST-5,08	#10005390
X9: Supply_{PWR}	2	MSTB 2,5/2-GF-5,08	MSTB 2,5/2-STF-5,08	#02005267
X10: Enable	5	MC 1,5/5-G-3,5	FMC 1,5/5-ST-3,5	#10006540

6.3 Connection of the Power Supply

6.3.1 Controller and Motor at X4

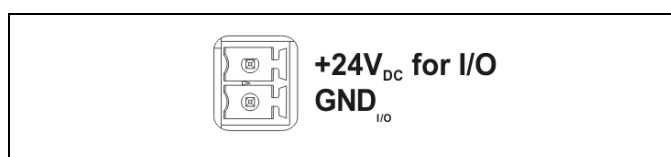

Fig. 14: X4 Connector: Supply I/O



DANGER

Danger of electric arcing!

Do not plug or unplug any connector when powered!

The 24 V_{DC} (absolute limit values: 19.2 to 30 V_{DC}) supply voltage I/O is connected to the X4 connector and supplies outputs, limit switches and fans.

The power requirement depends on the connected outputs and limit switches. Maximum 4 A are allowed.

6.3.2 24 V at X9

The controller and motor supply voltage is connected to the X9 connector.

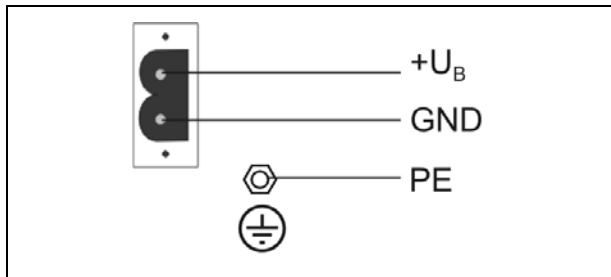

Permissible supply voltage range:

24 to 48 V_{DC}

Nominal voltage: 24 V_{DC}

Fig. 15: X9 Connector: Supply PWR

- When the MCC-2 is supplied by means of an unregulated filtered DC voltage (e.g. transformer), a load capacitor of min. 3,000 μ F should be used.
- Protective ground of the supply voltage should be connected to the earthing screw on the upper or lower side of the device.
- For strain relief the cable should be fixed with one of the cable clamps at the bottom or the top side of the device.

- The Motor voltage is fused with 6.3 A fast. 



Reducing the power supply reduces the losses and also the heat sink temperature.

Consider the relation between phase current und power supply:

maximum phase current at 24 V_{DC}: 1.2 A_{r.m.s.}

at 48 V_{DC}: 0.6 A_{r.m.s.}



DANGER

Danger of electric arcing!

Never plug or unplug the screw connectors when powered!

Remark: The maximum motor current is only reached when the supply voltage exceeds 40 V_{DC}



The MCC shuts down in case of under voltage $17 \text{ V} \pm 1 \text{ V}$. The error is set by the status bit and is indicated by the status LED which can be reset by a hardware or software reset (power stage reset). The power stage is deactivated in case of an error.

6.4 X7/X8 Motor Connector

6.4.1 Stepper Motor Connection

Suitable stepper motor types for operation with MCC-2:

- Two-phase stepper motors with 4, 6 or 8 lead wiring scheme and up to 1.7 A_{Peak} phase current
- Winding resistance under 10 Ohm
- Winding inductivity of a motor phase 0.5 to 10 mH
- To ensure electromagnetic compatibility (EMC), all parts of the motor housing should be conductively connected with each other.

The figure below shows the connection of a two-phase stepper motor with 4-lead wiring scheme and parallel connected windings:

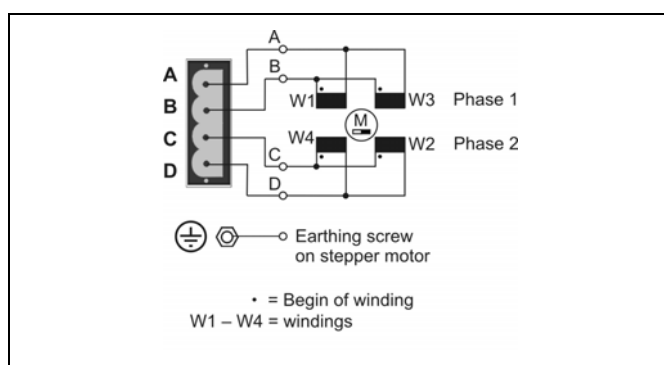

DANGER

Danger of electric arcing!
Do not plug or unplug any connector when powered!

Fig. 16: Motor connection to X7 or X8 connector

Depending on application and stepper motor design, other wiring modes are possible. See next chapter.



WARNING

Power stage damage in case of faulty connection!

- Before running the motor, the motor currents should be set to suitable values! See chap. 6, Putting into service.
- 5-phase stepper motors **must not** be operated with MCC-2 controllers. Connecting 5-phase stepper motors **would result in damaging the power stage.**



The supply voltage value affects the setting accuracy of the motor current. In addition the setting accuracy depends on inductance and resistance of the motor. The current can be set less exactly, if the current value is smaller than 600 mA.

We recommend to use the linear MCC-2 LIN controller if the accuracy of the motor current setting must be improved.

6.4.2 Wiring Schemes for 2-Phase Stepper Motors

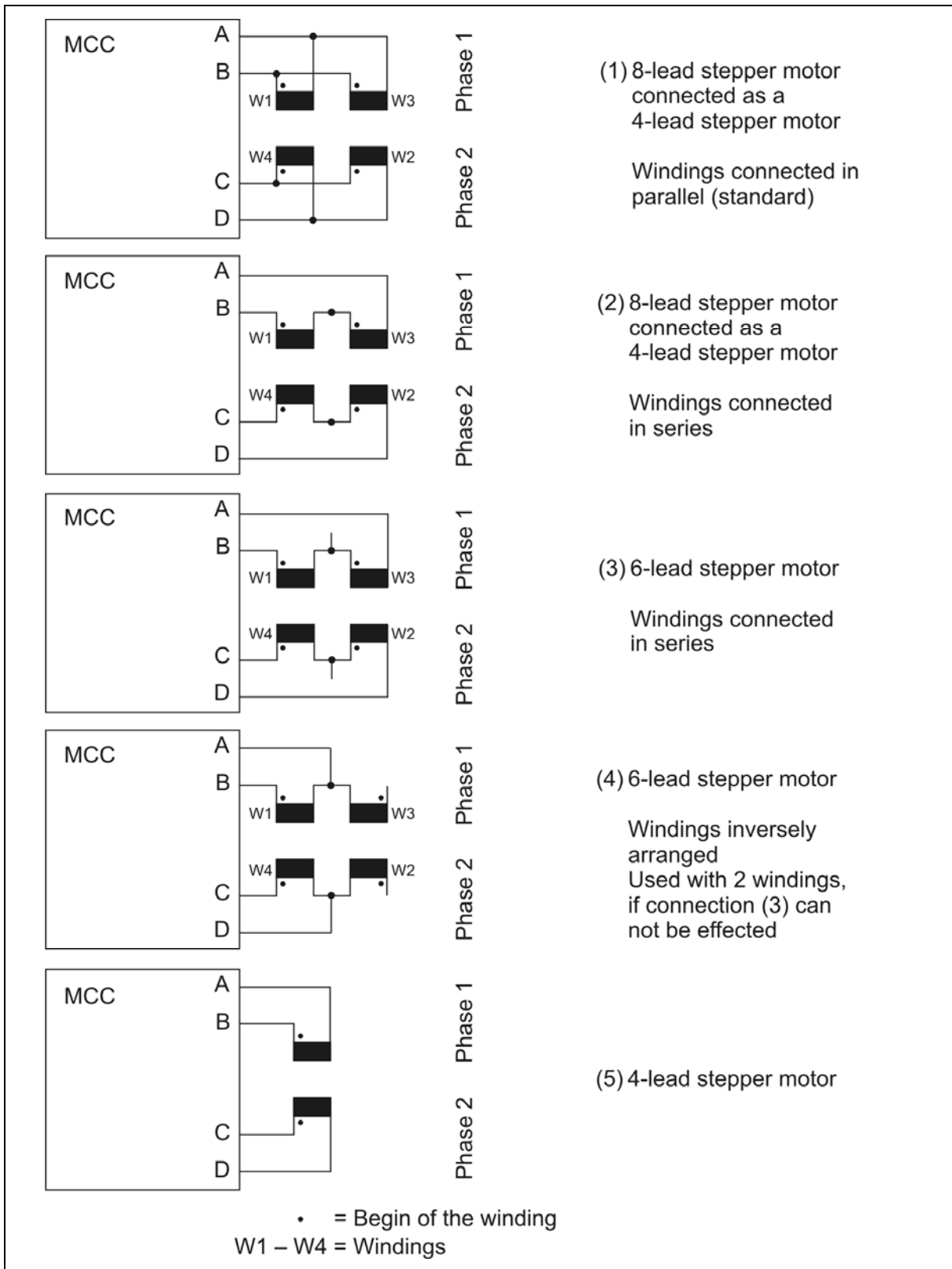

Fig. 17: Wiring schemes for 2-phase stepper motors



WARNING

Motor leads not used should be individually isolated (e.g. 6-lead motors)!

6.4.3 Motor Cable

Recommendations for Motor Cable Design:

Cable type: 5-pole with shielding mesh
(for stepper motors without earthing screw:
4-pole with shielding mesh)

Lead cross section: 1 mm² recommended, a smaller lead cross section can be used dependent on the maximum motor current and the motor cable length.

Acceptable motor cable length: dependent on power stage current setting and motor winding resistance

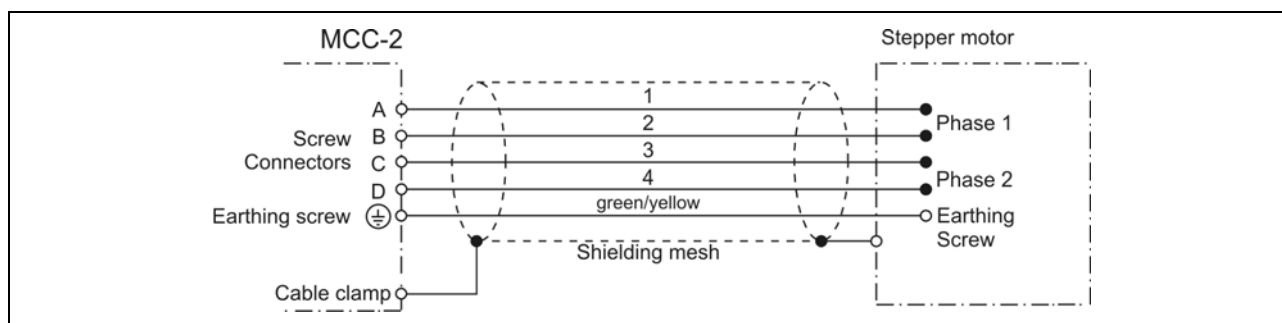

Fig. 18: EMC compliant motor cable wiring



DANGER

Danger of electric arcing!

Do not plug in or plug out motor cable leads when motor supply voltage is on!

- The PE lead (green/yellow) of the motor cable should be fixed at the earthing screw below the MCC-2 motor connector.
- The PE lead at the motor side of the cable should be fixed at the motor's earthing screw.
- For EMC compliant wiring it is important to conductively connect the motor cable shielding mesh with the controller housing. Use the cable clamps at the bottom and the top side of the MCC-2. Remove the external cable sheath in that range of the cable where you fix it with one of the cable clamps.
- The cables connecting motor and controller should not be interrupted (e.g. by connectors).
- At the motor side the cable's shielding mesh should be connected to the motor housing at a large area. We recommend to use special EMC type conduit fittings.
- In case of motors without adapted conduit fittings the cable shielding must be connected as near to the motor as possible and has to be applied to PE.

6.5 X5 Interface Connection

The X5 Com communication interface is available in the following designs:
as USB-, RS 485-, RS 232- or Ethernet interface.

Factory setting:

57 600 Baud

8 Data bits

1 Stop bit

No parity

Protocol: <STX> | Address | Data | Separator | Checksum | <ETX>

Baud rate and **Interface parameters** can be modified after installation of MiniLog-Comm in the menu item *Options/Interface Parameters*.



IMPORTANT



- If the MCC-2 is connected via Ethernet ensure that the **IP address is created by DHCP** (dynamic IP configuration).
Differently generated IP addresses are not identified.



- When the MCC-2 is connected to the PC by USB-interface, USB drivers have to be installed on the PC.



- The MCC-2 is connected to the PC as a stand-alone device.
An USB converter is needed, if several controller should be connected by USB. It is mounted either external or at the first MCC-2 with RS 485 interface.
See chapter 6.5.3 RS 485 interface.

6.5.1 USB Interface

MCC-2 and PC can be directly connected by the USB cable type A-B. The USB port of the PC (type A) is directly connected to the USB port of the controller (type B). The MCC-2 operates in the stand-alone mode.

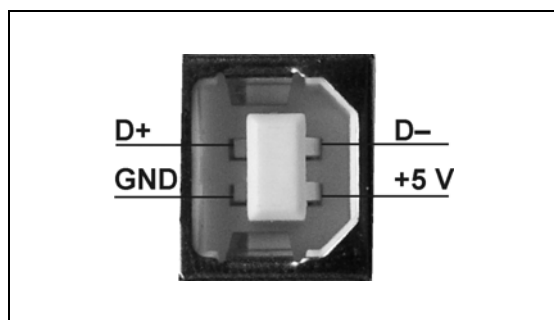

Fig. 19: X5 Com: USB port type B (DIN IEC 61076-3-108)

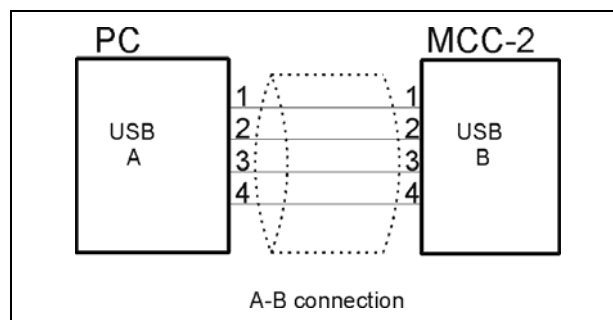
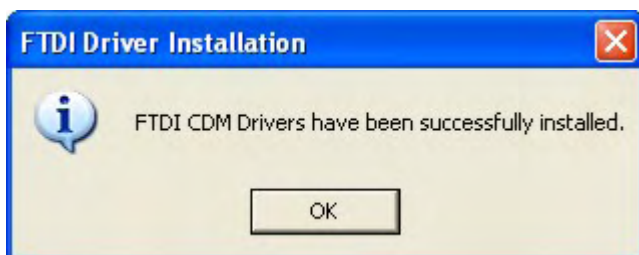

Fig. 20: Wiring scheme PC \leftrightarrow MCC-2 by cable A-B

USB Driver Installation (Windows)

- Insert the Phytion CD and open the folder **USB Driver** by the Windows Explorer. Select the **.exe**-program which goes with your system software and start it by double click. The following window is shown on desktop after a successful installation:



- Connect the MCC-2 directly or via USB converter to the USB port of your PC by USB cable.
- For checking the correct USB driver installation, continue as follows:
Start the device manager by clicking **Start**→**Settings**→**System control** and double-click on **System**. Then select the **Device manager** tab. The USB components can be found in **Computer**→**Ports** and in **Universal Serial Bus Controller**. Here the new USB-component is shown: **USB Serial Port (Com X)**
- You'll find information about the driver installation for the chip FT232R and more drivers for Linux and MAC on <http://www.ftdichip.com>.



- When the MCC-2 is connected to the PC by USB-interface, USB drivers have to be installed on the PC.
- Administrator authorizations are required for the driver installation.
- Use a USB cable with a maximum length of 2 m!
- If you want to test several USB devices, which are identical in construction, you should use the same USB port on the PC. Thus, you avoid to change the COM port number.

6.5.2 Ethernet Interface

The MCC-2 can be integrated into the firm's network by the Ethernet adaptor.

The port number of the MCC-2 controller is fixed to 22222 by Phytron.

IMPORTANT:



**The controller obtains its IP address over DHCP exclusively.
(dynamical IP configuration in every subnet)!**



The Ethernet connection via RJ 45 connector (X5 Com):

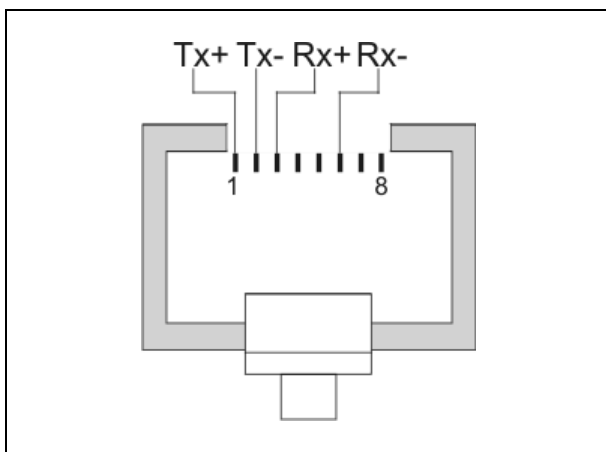

Fig. 21: X5: RJ 45 Ethernet connector

6.5.3 RS 485 Interface

When up to 16 MCC-2 are connected together in bus mode (RS 485/4-wire), an individual address has to be set on the rotary switch ‚Address’ for each MCC-2.

A USB/RS 485 converter has to be used for USB connection to the PC (Fig. 25).

Alternatively, a PC with RS 422 or RS 485/4 wire interface can be the master (Fig. 24).

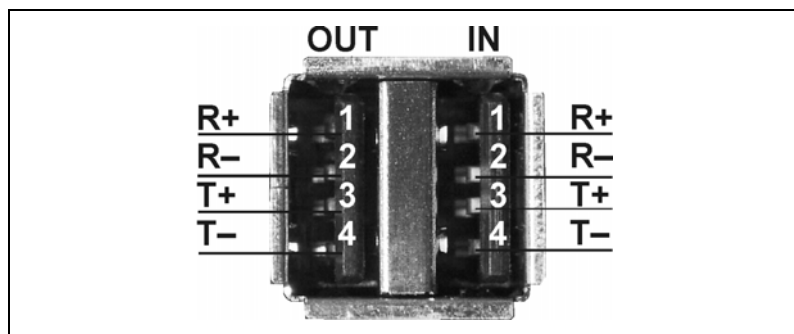

Fig. 22: X5 Com: connector type A (DIN IEC 61076-3-107)

PC with RS 485/4-wire- or RS 422 interface ↔ RS 485 bus

The figure below shows the RS 485 bus connection to MCC-2 by a RS 422 or RS 485/4-wire interface on PC:

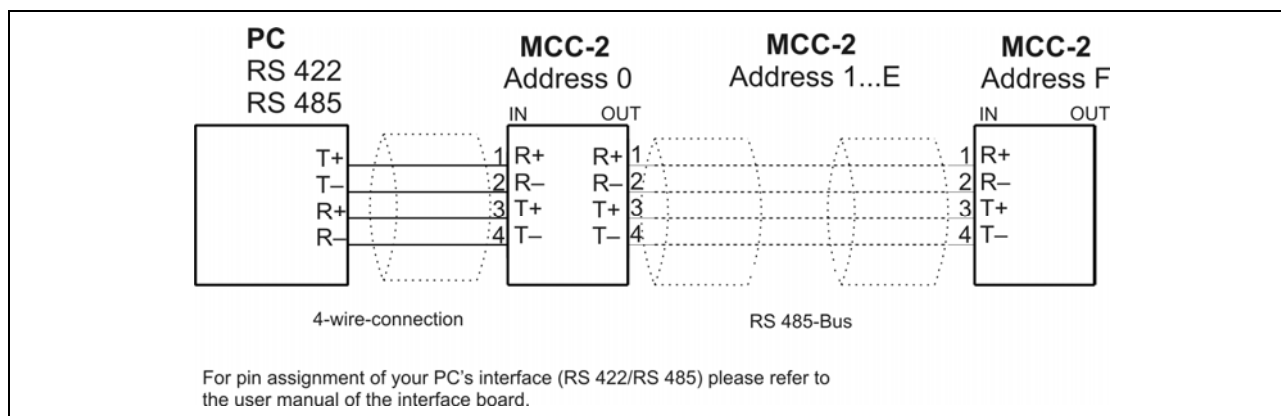

Fig. 23: Connection PC → MCC-2 with RS 422/485 interface

Remark:

- It is not necessary to use an external bus termination connector for RS 485 bus, because the bus termination resistors are already built-in the MCC-2.
- Both MCC-2 and MCC-2_{LIN} controllers can be operated in the bus mode at the same time.



The complete bus only operates, if all devices are supplied at X9 connector. If the supply voltage is disconnected on one MCC-2, all following devices on bus are without communication.

PC with USB interface ↔ Converter ↔ RS 485 bus

A USB/RS 485 converter has to be used for USB connection to the PC. An extra converter or a converter, which is installed on the first MCC-2 must be inserted.

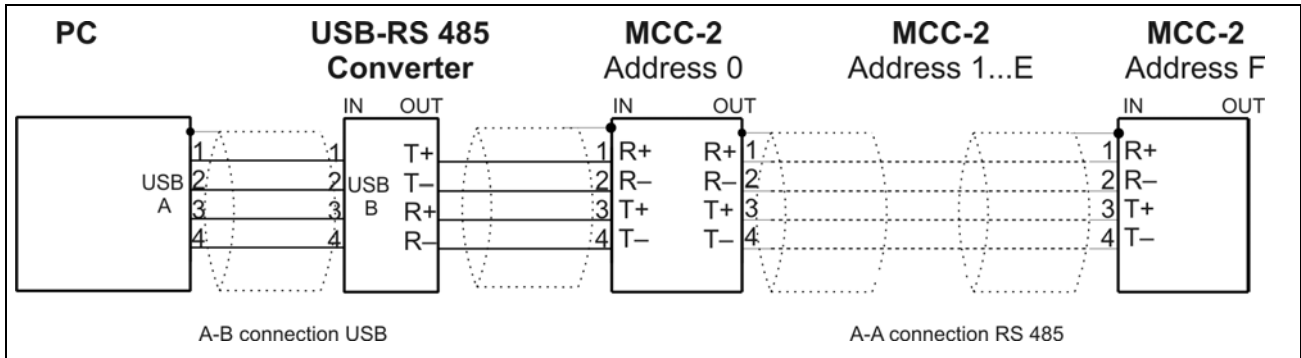

Fig. 24: Bus connection PC → MCC-2 with USB-RS 485 converter in RS 485 mode

The figure below shows the connection of the PC to MCC-2 by the Phytron USB-RS 485 converter.

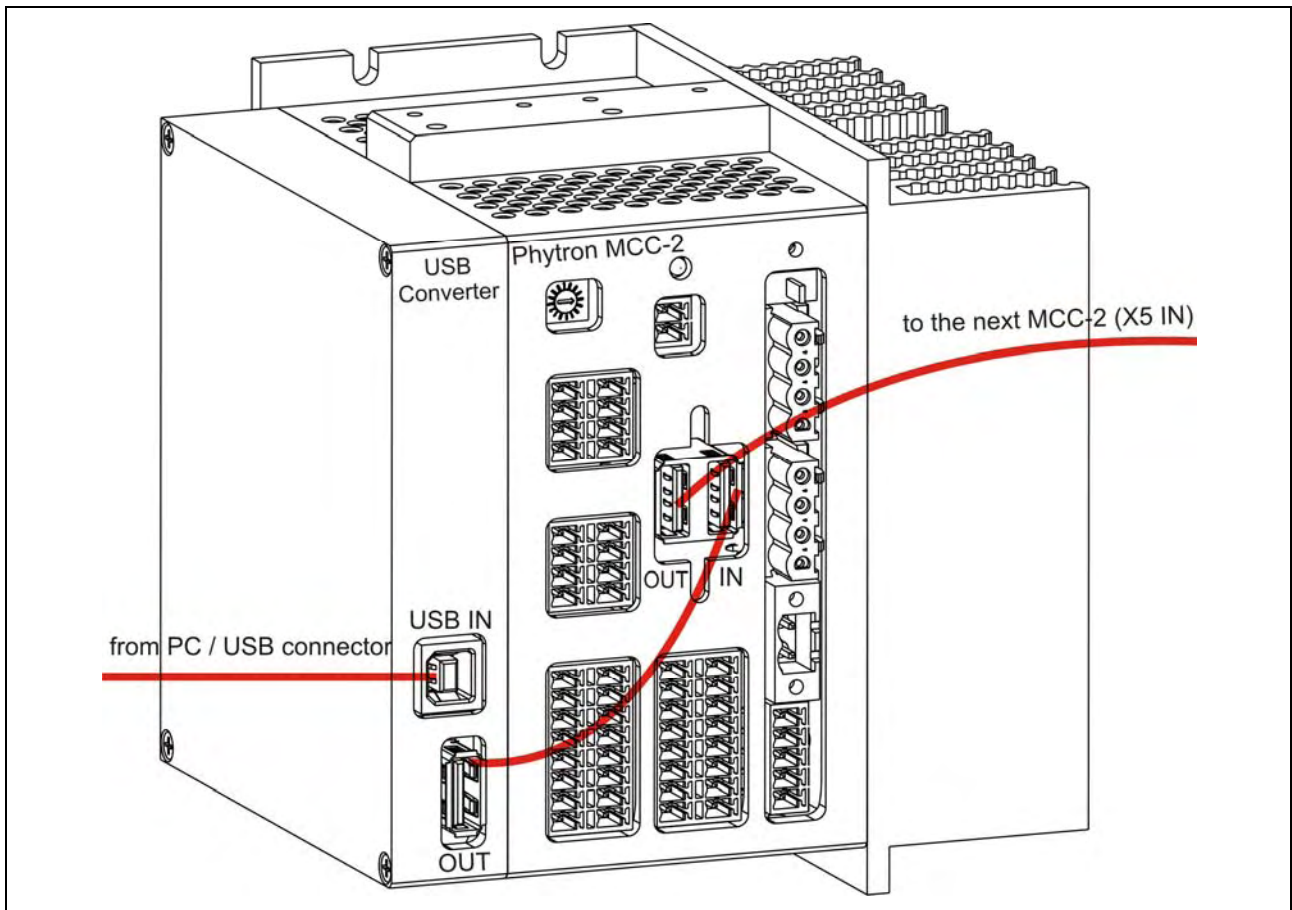

Fig. 25: Controller PC → MCC-2 with Phytron USB-RS 485 converter

6.5.4 RS 232 Interface

The MCC-2 can be used as single device by RS 232 interface.

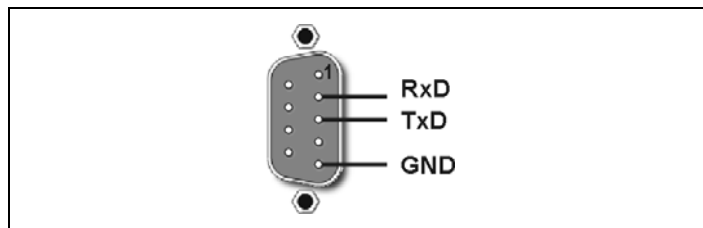

Fig. 26: 9 pole D-sub male connector acc. to DIN 41652

The following figures point out the cable connections to a PC with RS 232 interface. Depended on the type this can be a 9 pole or a 25 pole D-sub female connector.

Connecting Cable PC – MCC-2

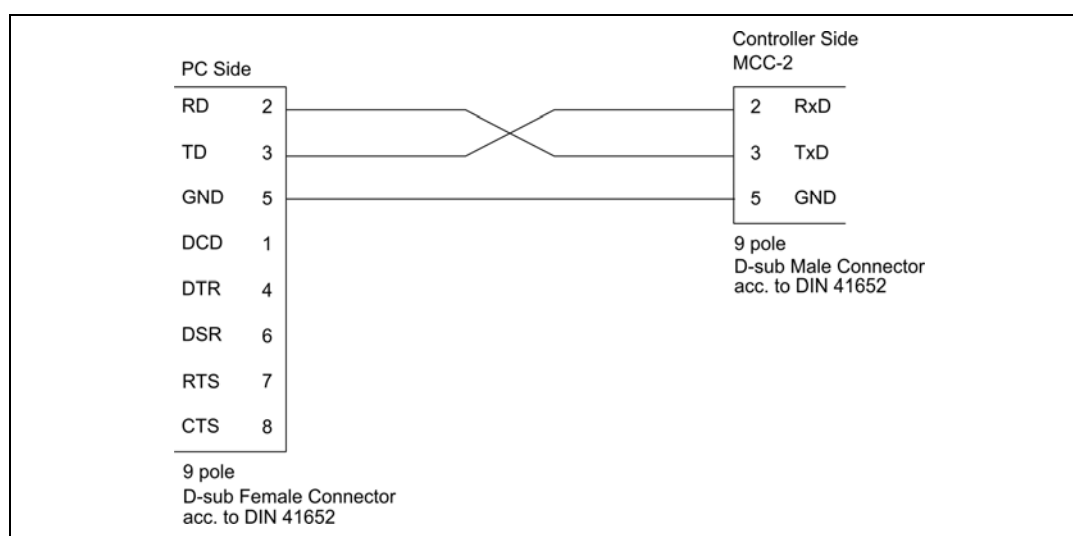

Fig. 27: PC (9 pole female connector) <-> Controller MCC-2

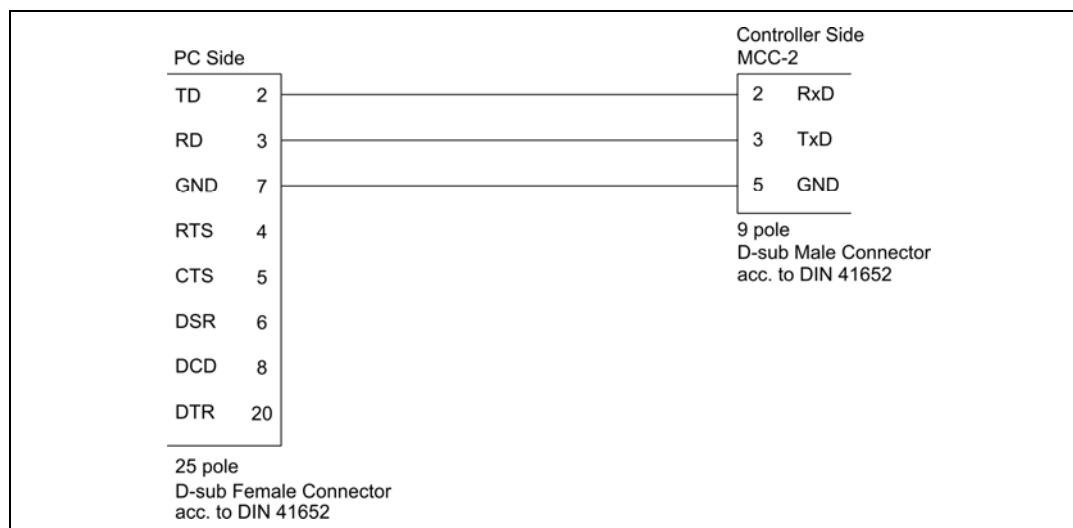

Fig. 28: PC (25 pole female connector) <-> Controller MCC-2



115 200 Baud are allowed as maximum baud rate to receive correct data.

6.6 Signal Interface Connection

6.6.1 X1 AD Converter

The X1 analog inputs can be used for voltage measurement, as well as e.g. for a joystick as AD converter.

The 5 V_{DC} ±3 % / max. 100 mA voltage is supplied by the MCC-2.

Input voltage: 0 to 5 V

Resolution: 10 Bit

A/D conversion time: about 15 µs

Input resistance: 47 kΩ

The input A/D ENABLE is a digital input (max. 5 V), which can be used e.g. as joystick Enable. This input is only analyzed by software (see MiniLog-Comm).

Specific information for processing the input signals you'll find in the programming manual MiniLog-Comm.

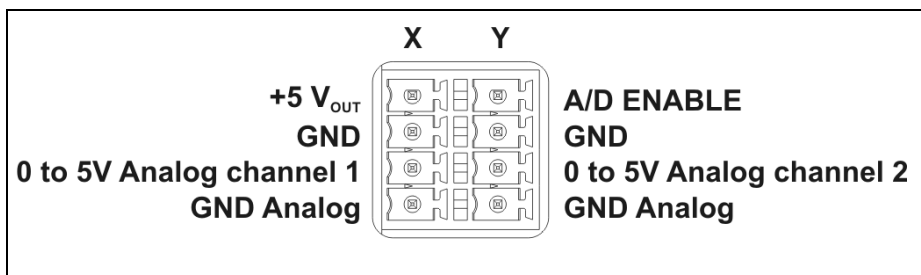

Fig. 29: X1 Pin assignment



CAUTION

Danger of device damage!

Do not exchange X1 and X2!

To improve the accuracy of measurement of the AD converter, use a shielded cable. We recommend using the shielding as GND analog. With PELV Grounding (except for SELV supply, see page 16 and 17) this can be additionally wired to PE. Make sure that no reverse current couple in to the GND Analog shielding. GND Analog should not be connected to PE, if there is SELV supply.

6.6.2 X2 Limit Switch Input

The controller is designed for connecting two limit switches type PNP NCC or PNP NOC per axis. This type of limit switch can realize cable breaks.

Mechanical opening limit switches may be also connected.

The supply voltage for the limit switches and outputs has to be supplied on connector X4.

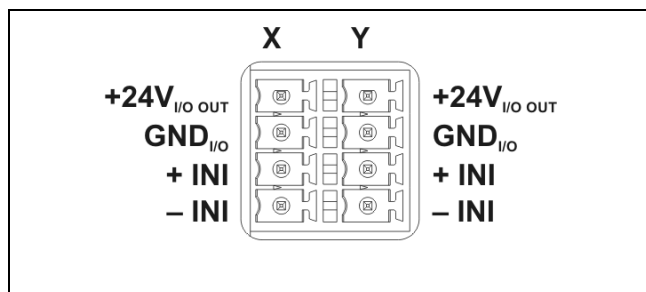

Fig. 30: X2 Pin assignment



CAUTION

Danger of device damage!
Do not exchange X1 and X2!

6.6.3 X3 Digital Inputs/Outputs

MCC-2 controllers have each eight digital electrically insulated inputs and outputs.

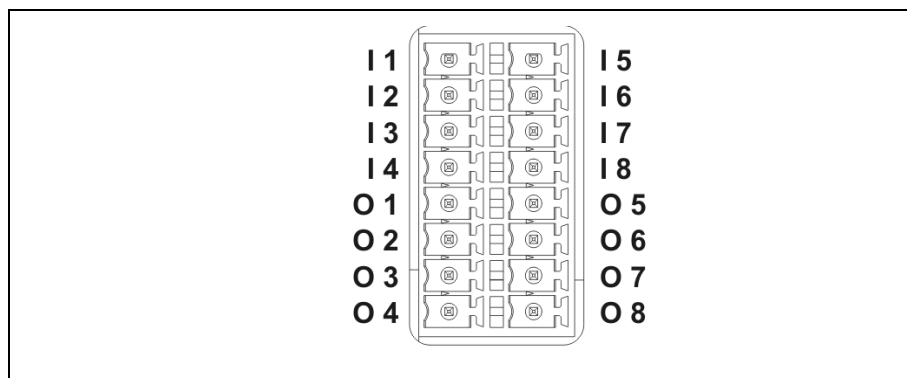

Fig. 31: X3 Pin assignment



CAUTION

Danger of device damage!
Do not exchange X3 and X6!

Inputs

The inputs are connected to a common ground connection ($GND_{I/O}$ at X2, X4 or GND at X9).

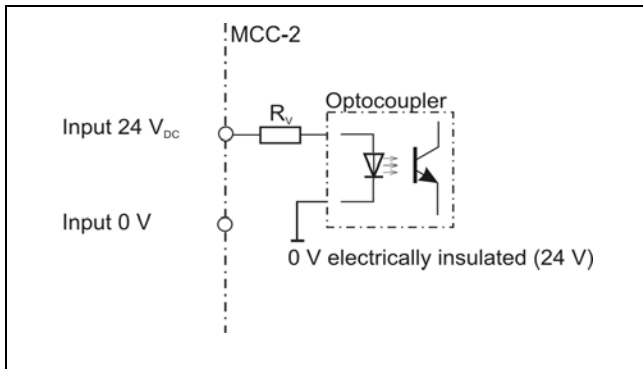

Input level: $24 V_{DC}$

The input circuit protective resistor of $3.3 k\Omega$ corresponds to $7 mA$ nominal driver current at $24 V_{DC}$.

Signal level Low: $< 0.4 V_{DC}$

Signal level High: $20 - 30 V_{DC}$

Fig. 32: Input circuit diagram

Outputs

The overload-safe outputs are equipped with protective diodes to protect the internal circuitry. In the case of inductive loads (e.g. relay) each output should be additionally wired with a protective diode mounted near the load in order to avoid EMC problems.

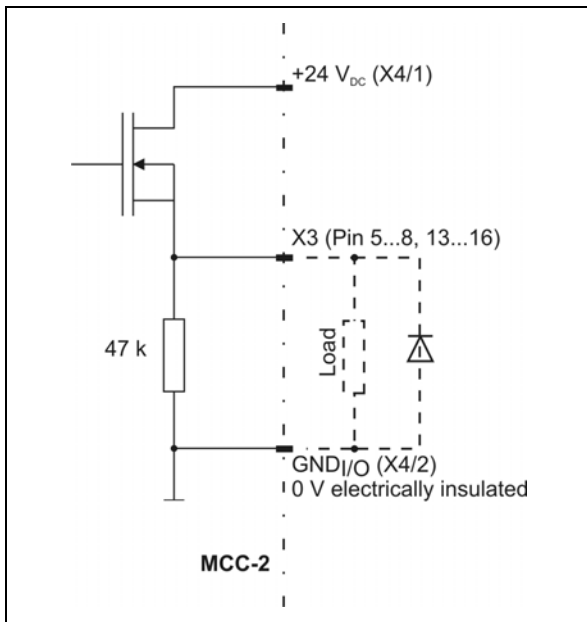

Max. $1 A$ current each output

Up to $3 A$ for all outputs

Fig. 33: Output wiring example

6.6.4 X6 Encoder Connector

- Connection of one encoder per axis.
- Incremental encoder with quadrature signals or absolute encoder acc. to SSI-standard.
- The incremental encoder supply voltage, $5.3 V_{DC}$ / max. 200 mA each encoder, is generated by the controller.
- Use shielded twisted pair wise cables for encoder connection. The transmission mode includes no protection against faulty transmission values.

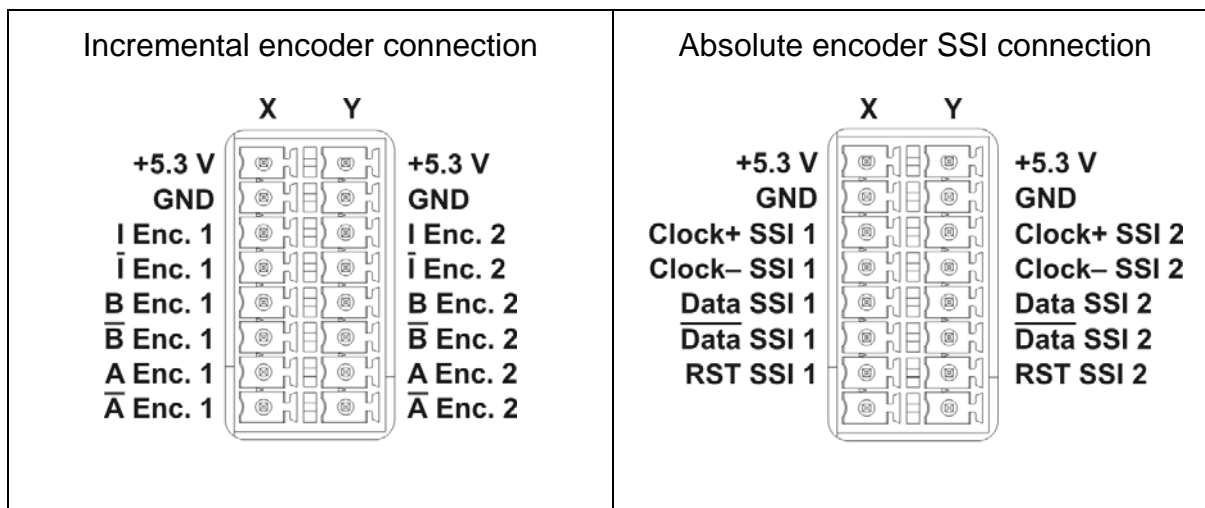

Fig. 34: X6 Encoder connector

- When using encoders, the parameters P34 to P39 should be checked and adapted (MiniLog-Comm communication software):
 - P34 incremental encoder / absolute encoder
 - P35 encoder resolution (SSI)
 - P36 encoder as counter
 - P37 not used
 - P38 preferential encoder direction of rotation
 - P39 conversion factor (one increment corresponds to ...)
- It is possible to operate one axis with an absolute encoder and the other axis with an incremental encoder.



CAUTION

Danger of device damage!

Do not exchange X3 and X6!

Danger of damage!

Connect the correct encoder type!

Do not parameterize an incremental encoder as SSI.

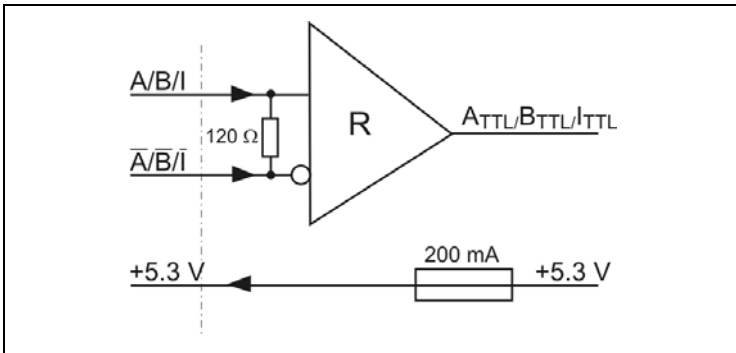

Fig. 35: Wiring of incremental encoder

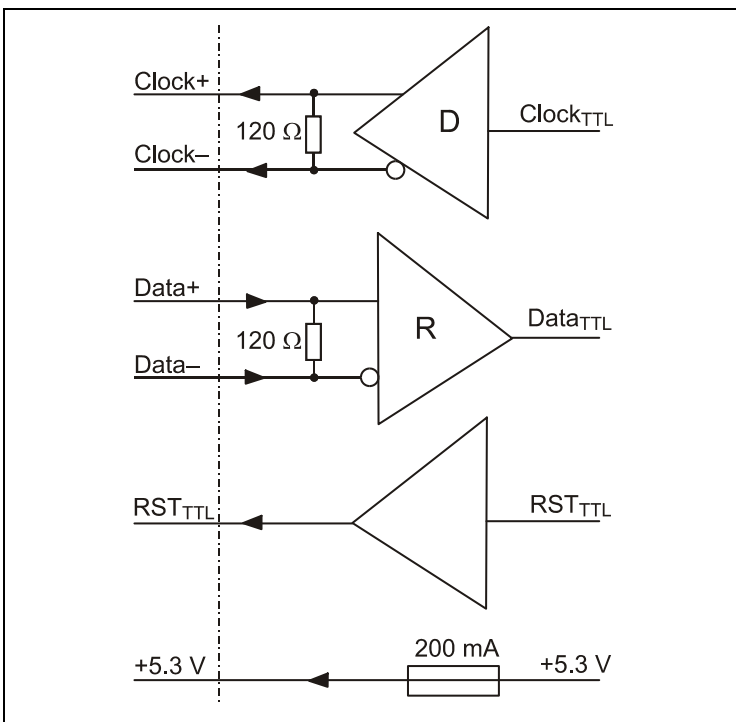

Fig. 36: Wiring of SSI absolute encoder

6.6.5 X10 Enable Connector

- The power stage can be deactivated independently of the logic signals (enable connector X10).
- Two opto-decoupled Enable inputs are used to activate the motor supply.



Both Enable inputs must be wired for activation!

- The Monitor Enable output is used to check the Enable inputs A and B, i.e. when both inputs are wired, the Monitor Enable output is set to 'high'.

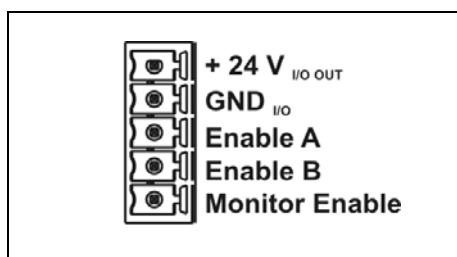

The function Enable doesn't fulfill 'Protection against unexpected start' according to EN 945-1 for application in the extended safety sections.

Fig. 37: X10 Connector Enable

- The Enable inputs A and B can be permanently activated by bypassing the inputs with the +24 V_{DC} output.

Important: This will work only, if +24 V_{DC} is supplied to the X4 connector.

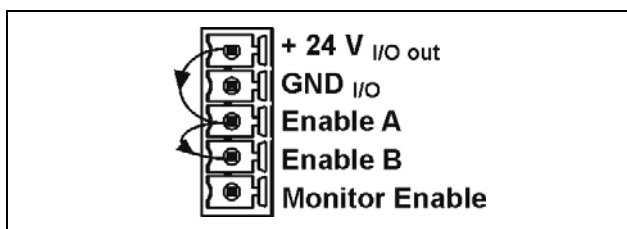

Fig. 38: Activation of A and B Enable inputs



A deactivation of the Enable signals during increasing stop and run current values can cause an error and the axes will be stopped by an emergency stop. If the Enable functionality should be checked e. g. after power-on, we recommend either to reduce the current parameters or to detect the extern deactivation in the Minilog program by commands and to reset the axes (see manual MiniLog).

Minilog command for reading the system status:

ST, Bit 5 is set (32_{Dec}) = input Enable is OK

See also programming manual MiniLog for MCC.

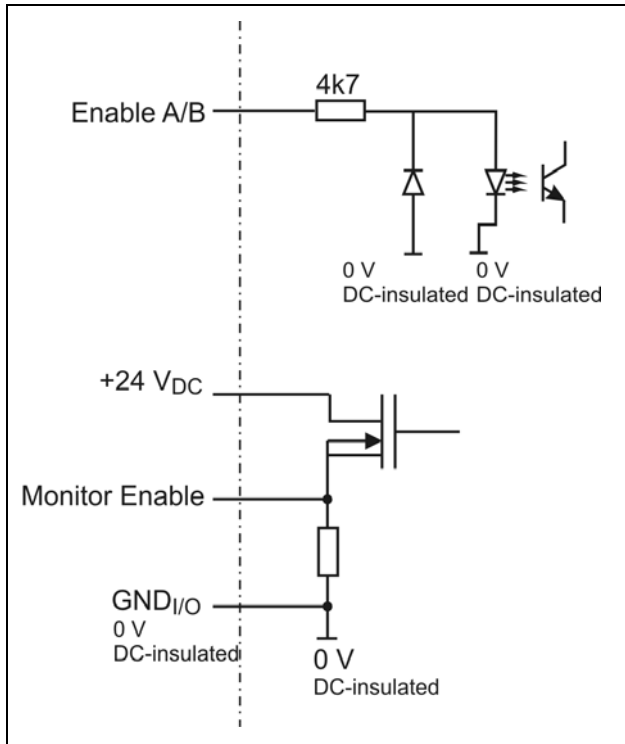

Fig. 39: Enable connector wiring

7 Putting into Service and Test

7.1 Test the Communication between Controller and PC

Connect the serial interface of the PC to the controller (X5), see Chap. 1.2.

Connect the supply voltage PWR to the controller (X9). The LED should light green.

Set the Remote/Local switch to REMOTE.

Switch on the PC.

Das mitgelieferte Programmpaket MiniLog-Comm für Windows installieren.

Select the required settings in MiniLog-Comm, menu item *Options/Interface parameters*, and save them: Active COM, transmission protocol and baud rate.

The baud rate in the controller can be changed by clicking on **Advanced >>** and can be saved by **Set!**.

Baud rates MCC-2	
Can be selected in menu item <i>Options/Interface parameters</i> or programming instruction	
9 600	38 400
14 400	57 600
19 200	115 200
28 800	
Factory settings	

Baud rate programming instruction:

ICpSnnn

IC Code: programming a baud rate
 p Port number 1
 S Write (Schreiben)
 nnn Enter baud rate

Data format for transmission:

No Parity

1 Stop bit

8 Bit ASCII-Code

57 600 Baud

All **instruction strings** must have the following format: **STX Data ETX**

Control characters: see ASCII table

The programming instructions are listed in the MiniLog programming manual.

7.2 Test Stepper Motor(s), I/Os and Limit Switches

If not done before, now inputs, outputs, limit switches and stepper motor(s) should be wired. Supply voltages should be wired after that!



Do not connect or disconnect screw terminals as long as the matching supply voltage is on!

1. Switch on the PWR supply voltage. The LED will light green.
2. Switch on the supply voltage for I/O.
3. Start MiniLog-Comm.
4. Select menu item *File/New/Parameter* for motor current setting.
Run current, stop current and boost current¹ can be set in the range 0 to 1.0 A_{r.m.s.} independent from each another. Stage 1 = 0.04 A_{r.m.s.} to stage 25 = 1.0 A_{r.m.s.}
In menu item *Transmission/Send/Parameter* the parameter list is saved in the MCC-2.
On delivery the following settings are valid:
Run current: 0.24 A, stop current: 0.08 A, boost current: deactivated



Set motor currents corresponding to the motor winding parameters!
See chap. 6.4

5. In the menu item *Parameter* the step resolution can also be set between full step and 1/256 step. It is better to choose a high step resolution in most application situations, because the motor will run more smoothly.
6. After the motor currents have been set to suitable values you can test the motor's run by selecting the menu items *Transmission/Direct Mode* or *Transmission /Operation*.
7. Menu item *Transmission/Direct Mode*
Many customers are already familiar with MINILOG program instructions. They can enter all types of MINILOG instructions into a dialog box. The instruction is executed at once.
Example: Enter *X+200*
The motor axis 1 drives 200 steps in +direction.
The corresponding instruction for the other motor would be: *Y+200*

¹ **Run current** is the motor's rated current for normal operation without acceleration or deceleration phases.

Stop current is a reduced current for motor standstill (about 50% of the run current).

Boost current is the motor current for acceleration and deceleration. During these phases the motor needs more energy as during constant speed.

The boost current should be set to 120 to 130% of the run current. On delivery, boost is deactivated, that means the motor will always run with the selected run current.

8. An icon in the menu bar *Transmission/Operation* opens the following dialog box which enables you to drive the motor per mouse click.

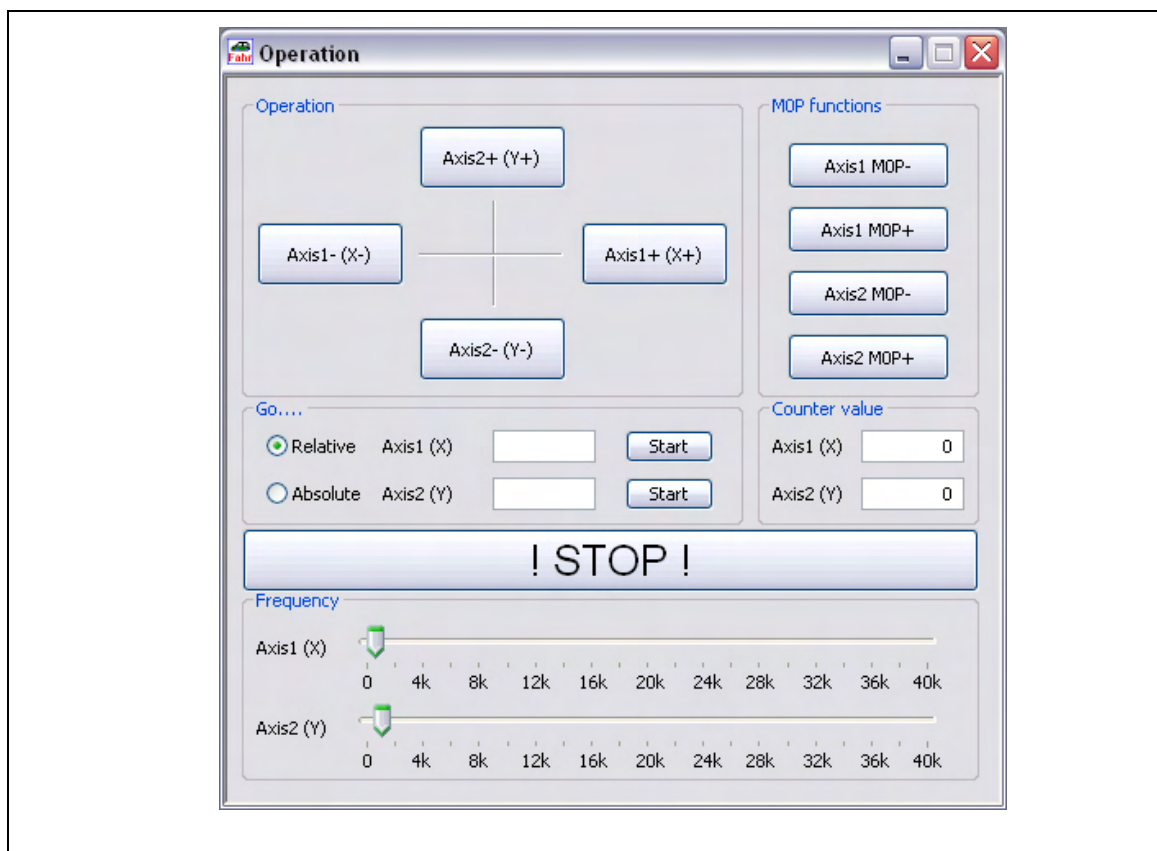

9. Click on simply one of the buttons **Axis1- (X-)** to **Axis2+ (Y+)**. Direction + means clockwise, seen onto the motor axis from outside.

If the motor should move in the wrong direction, exchange the connecting leads of one motor phase, e.g. A and B.

10. You can enter drive instructions for both axes into the window "Drive relative ... "
 The symbol + or – before the entered number of steps defines the direction.
 When you click on the button **Start** the instruction will be executed. Now the button has the marking **! STOP !** in order to cancel the movement if required.
11. You can change the drive frequencies of both motors with two slider controls at the bottom of the window 'Frequency'.
12. You can initialize each axis with click on one of the buttons **Axis1 MOP-** or **Axis2 MOP+**. The initializing can be cancelled by **! STOP !**.
13. Another MiniLog-Comm window allows to test inputs and outputs.

8 Programming

8.1 LabVIEW®

LabVIEW is a graphical programming environment with symbols.

Graphic icons (in the programming language G), which are representing a particular function, are linked. These programs are called virtual instruments (VIs).

Phytron has created special VIs for MCC-controllers. The user therefore needs LabVIEW qualification. Basic programming knowledge like data types, loops etc. are required.

The MCC-VIs are developed for LabVIEW 8.0 and higher.

A detailed description can be found in the LabVIEW-VIs MCC manual.

8.2 MiniLog

The "Phytron Programming Language" MiniLog is welltried for editing sequential programs for machine controllers.

Complete sequential programs can be realized with MiniLog: drive instructions, initializing axes, sub programs, jump instructions, reading and setting registers and many other special instructions (see MiniLog programming manual).

MCC-2 controller can store MiniLog programs up to 128 kB program memory.

For editing and managing MiniLog programs, the MiniLog-Comm communication software for PC is delivered together with the controller. Actual MiniLog-Comm program versions can be downloaded from the Phytron homepage: <http://www.phytron.de/>

In the MiniLog-Comm menu item *File/New* you can enter and edit parameters, sequential programs and registers.

Please refer to the MiniLog programming manual for all programming instructions.

9 Temperature and Ventilation

The mounted fans in the heat sink are supplied with 24 V, if the X4 connector is connected to the power supply. The two point temperature controls allows the fan to switch on at about 48 °C and to switch off at about 42 °C.



The maximum heat sink temperature of 75° C may not be exceeded!
Switch off the device!

The power consumption of the MCC is approximately linear depending of the motor current. It is maximum 135 W at a nominal voltage of 24 V.

The maximum acceptable ambient temperature depending on the phase current results from the derating diagram below (Fig.13).

The MCC-2 can be operated with a phase current up to 1 A in the 2-axis operation at an ambient temperature of 50 °C.

The MCC-2 can be operated with the maximum phase current of 1.2 A_{r.m.s.} at an ambient temperature of 40 °C.

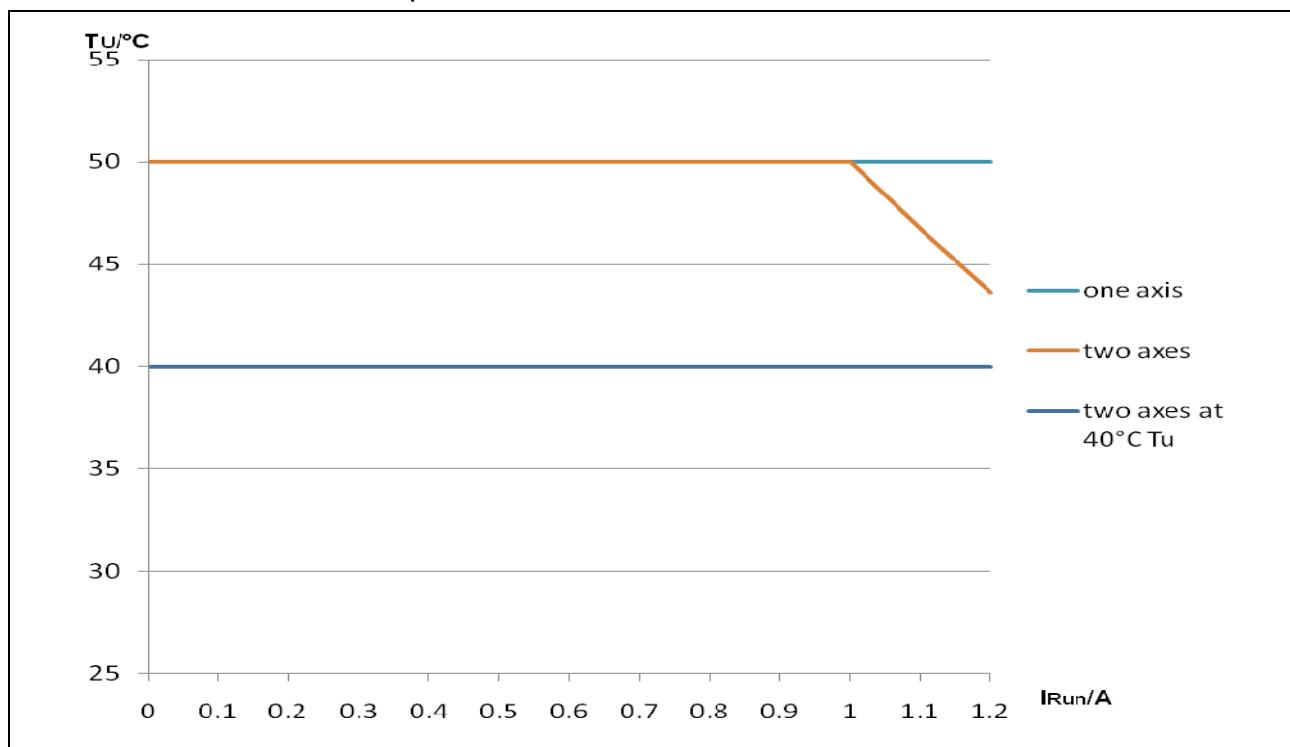

Fig. 40: Derating

Technical data of the fan:

SUNON type GM1235PFV2-8

Capacity: 11 m³/h

7500 rev/min

internal power supply : +24 V_{DC}

10 Warranty, Trade Marks and Protective Measures

In this chapter warranty, trade marks and ESD protective measures are described.

10.1 Warranty

The MCC controllers are subject to legal warranty. Phytron will repair or exchange devices which show a failure due to defects in material or caused by the production process. This warranty does not include damages which are caused by the customer, as there are, for example, not intended use, unauthorized modifications, wrong treatment or wrong wiring.

10.2 Trade Marks

In this manual several trade marks are used which are no longer explicitly marked as trade marks within the text. The lack of this signs may not be used to draw the conclusion that these products are free of rights of third parties.

MiniLog-Comm is a trade mark of the Phytron GmbH.

Microsoft is a registered trade mark and WINDOWS is a trade mark of the Microsoft Corporation in the USA and other countries.

10.3 ESD Protective Measures

All the products which we deliver have been carefully checked and submitted to a longterm test. To avoid the failure of components sensitive to electrostatic discharge (ESD), we apply a great number of protective measures during manufacturing, from the component input check until the delivery of the finished products.

Warning:

Manipulation of ESD sensitive devices must be effected by respecting special protective measures (EN 61340-5). Only return the modules or boards in adapted packaging.

Phytron's warranty is cancelled in case of damages arising from improper manipulation or transportation of ESD modules and components.

11 Index

A

AD converter 36
 Adaptor cable 35
 Address switch 8
 Ambient temperature 47

B

Baud rate 30
 Block diagram 8
 Boost current 44

C

Cable clamp 19, 26, 29
 Connectors 22

D

DHCP 32
 Dimensions 21

E

Earthing screw 26, 29
 EMC 19, 27
 EMC compliance 29
 Encoder 39
 ESD protective measures 48
 Ethernet 32

F

Fan 47
 Firmware 8
 Fuse 22

H

Handling 14

I

Incremental encoder 39
 Input level 38
 Inputs 35, 37
 Installation 13
 Interface 22

L

LabVIEW 46
 LED 43
 Limit switch 6, 35, 37, 44
 LOCAL 7

Low voltage error 6

M

MiniLog 46
 MiniLog-Comm 4, 8, 39, 44, 46
 Motor cable 29
 Mounting place 23

O

Operating mode 7
 Operator panel 10
 Outputs 35, 37, 38
 Over temperature 6

P

PE 19, 26, 29
 PELV 16
 Phase current 22, 27
 Port number 32
 Power stage 6
 Programming 46
 Protection against unexpected start 41
 Protective diode 38
 Protective measure 16
 Putting into service 43

R

Rail mounting 23
 Rap holes 23
 REMOTE 7
 Reset push button 7
 RJ 45 32
 RS 232 30, 35
 RS 422 33
 RS 485 7, 30, 33
 Run current 44
 Run frequency 22

S

Screws 23
 Shielding mesh 19, 29
 Step resolution 22
 Stepper motor 22, 27
 Stop current 44
 Supply voltage 22

T

Temperature 22

Touch voltage 17
Trade marks 48

U

Under voltage 22
USB 30, 31
USB Driver 31, 32
USB Port 31
USB-driver 30

V

Virtual instrument 46

W

Wall mounting 23
Warranty 48
Weight 21
Winding inductivity 27
Winding resistance 27

