

# MSD MINI 172-70 MSD MINI 172-140

phytron®

## Bipolar Stepper Motor Power Stages with Integrated Supply Unit





**MSD MINI 172-70 POWERPACK**

**MSD MINI 172-140 POWERPACK**

**Bipolar stepper motor power stage  
with integrated supply unit**

Manual	<input type="checkbox"/>	MSD MINI 172-70
	<input type="checkbox"/>	MSD MINI 172-140
	<input type="checkbox"/>	Special version MSD MINI 172-70-115V
	<input type="checkbox"/>	Special version MSD MINI 172-140 without setting switches
Serial number.: .....		
... modification pages included		



**Description**

---

**Summary**

	Page
<b>1 Description</b> .....	4
1.1 MSD MINI POWERPACK bipolar stepper motor power stages .....	4
1.2 Technical characteristics .....	5
1.2.1 General .....	5
1.2.2 Dimensions - MSD MINI 172-70 POWERPACK .....	7
1.2.3 Dimensions - MSD MINI 172-140 POWERPACK .....	8
1.2.4 I/O connector .....	9
1.2.5 Connection to type SPS control units .....	10
1.2.6 Screw terminal motor connection .....	11
1.2.7 Screw terminal mains connection .....	11
1.3 Description of operation .....	12
1.3.1 Full step / half-step / ministep modes .....	13
1.3.2 Boost .....	14
1.3.3 Overdrive .....	15
<b>2 Motor connection</b> .....	17
2.1 Connection of different types of stepper motors .....	17
2.2 Motor cables .....	18
2.3 Shielding .....	18
2.5 Motor brake .....	18
<b>3 Inputs</b> .....	19
3.1 Control pulses .....	20
3.2 Motor direction +/- .....	20
3.3 Boost .....	20
3.4 Deactivation .....	21
3.5 Reset .....	21
3.6 Brake .....	21
<b>4 Outputs</b> .....	22
4.1 Ready .....	22
4.2 Error .....	22
<b>5 Front panel controls</b> .....	23
5.1 LEDs .....	23
5.2 Setting switches .....	24
<b>6 Putting-into-service</b> .....	25
<b>7 Accessories</b> .....	26
<b>8 Special versions</b> .....	26
<b>9 Quality assurance system</b> .....	27
<b>10 Index</b> .....	28

## Description

### 1 Description

#### 1.1 MSD MINI POWERPACK bipolar stepper motor power stages

MSD MINI 172-70 POWERPACK and MSD MINI 172-140 POWERPACK stepper motor power stages meet the most stringent requirements. MSD MINI POWERPACKs include a supply unit and can therefore be connected directly to the 230 V<sub>AC</sub><sup>1)</sup> mains voltage .

MSD MINI POWERPACK stepper motor power stage control signals can be delivered by all types of control units, provided they integrate a stepper motor interface. These power stages are used to connect 4-, 6- or 8-lead two-phase stepper motors. Furthermore, they can supply a permanent magnet motor brake.

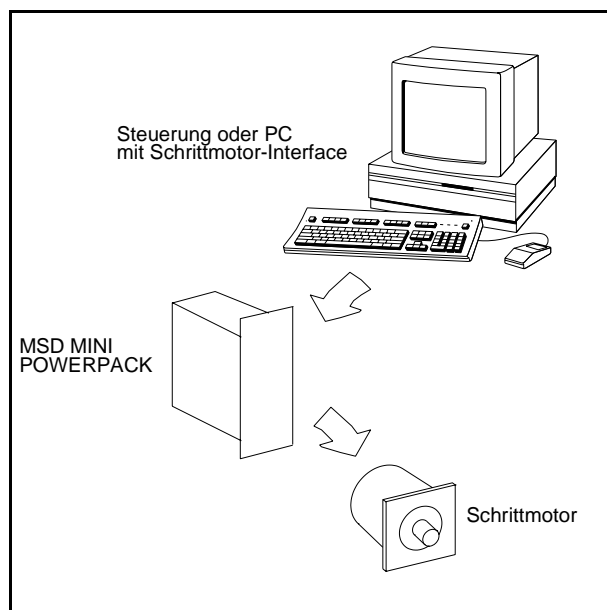

Fig. 1

- MSD MINI 172-70 POWERPACK:  
phase currents up to 12 A<sub>r.m.s.</sub><sup>2)</sup> at 70 V
- MSD MINI 172-140 POWERPACK:  
phase currents up to 12 A<sub>r.m.s.</sub><sup>2)</sup> at 140 V
- Synchronous chopped current regulation according to Phytron's patented SYNCROCHOP principle
- Setting switches are used to program individually the run and stop currents as well as the boost current during acceleration and deceleration.
- MSD MINI 172-140 POWERPACK:  
Dynamic boost function "OVERDRIVE" within the higher frequency range.
- A setting switch selects the resolution: full step, half-step, 2/5, 1/4, 1/5, 1/10 or 1/20 step. This switch is also used to program the preferential motor direction.

- Optocoupler-isolated signal inputs:  
The use of RS422 signals is recommended to increase immunity to disturbance signals. The unit can also be driven by open collector type signals.
- Mains supply:  
A ring transformer provides galvanic separation.
- Compact and rugged design adapted for wall mounting with brackets or 19"-rack mounting.

1) MSD MINI 172-70 POWERPACK is also available in a special version for 115 V<sub>AC</sub> supply (p. 26)

2) This corresponds to a maximum current  $I_{\max} = 17 \text{ A}$ . The maximum current is computed by  $I_{\max} = \sqrt{2} \cdot I_{\text{r.m.s.}}$  and flows when only one motor phase is energized.

### 1.2 Technical characteristics

#### 1.2.1 General

**Description**

	<b>MSD MINI 172-70 POWERPACK</b>	<b>MSD MINI 172-140 POWERPACK</b>
<b>Supply voltage</b> [V <sub>AC</sub> ]	230 V <sub>AC</sub> ±10% 50-60 Hz Power consumption 700 W max.	230 V <sub>AC</sub> ±10% 50-60 Hz Power consumption 1400 W max.
	<u>Special version</u> 115 V <sub>AC</sub> : refer to p. 26	
	Mains fuse (behind front panel): T 4 A	Mains fuse (behind front panel): T 6.3 A
	The current required depends mainly on the motor current programmed and the motor used, its maximum value is 3 A <sub>AC</sub> .	The current required depends mainly on the motor current programmed and the motor used, its maximum value is 6 A <sub>AC</sub> .
A starting current limiter and interference filter are integrated in the module.		
<b>Stepper motor</b>	Two-phase 4-, 6- or 8-lead stepper motor Minimum inductance of a motor phase: 0.5 mH	
<b>Motor brake</b> (optional connection)	Stepper motors with permanent magnet motor brake 24 V <sub>DC</sub> / 1 A max. The supply voltage for the brake is short-circuit protected, the brake is activated by means of an input.	
<b>Step resolution</b>	Full step, Half-step, 2/5, 1/4, 1/5, 1/10, 1/20 step Programming by means of a setting switch	
<b>Motor currents</b>	Start, stop and boost currents are individually set by means of setting switches.	
<b>Max. motor currents</b>	17 A	
	The maximum motor current flows when the switch is set at position F (highest value) and when one single motor phase is energized. If both motor phases are energized, the maximum current is $I = 17 \text{ A} \cdot \sqrt{2} = 12 \text{ A}$	
<b>Duty</b>	70% for a S6 duty cycle according to VDE 0530	60% for a S6 duty cycle according to VDE 0530
<b>Inputs</b>	The inputs are optocoupler-isolated and can be controlled via a RS422 line signal or an open collector signal.	
Control pulses	Maximum frequency of the drive pulses: 250 KHz, minimum pulse width: 2 μs	
Motor direction +/-	When the optocoupler is energized, the motor rotates in the reverse direction (as compared to the preferential motor direction selected).	
Boost	When the optocoupler is energized, the motor current is the same as the Boost parameter setting.	
Deactivation	When the optocoupler is energized, the motor is deactivated (the motor current is cut off).	

**Description**

	MSD 172-70 POWERPACK	MSD MINI 172-140 POWERPACK
Reset input	A Reset causes resetting of all error messages and initialization of the monitoring circuits.	
Brake input	When the optocoupler is energized, the brake supply voltage is delivered. The brake is released as long as this input is activated.	
<b>Outputs</b>	Optocoupler, open-collector Darlington type outputs $I_{max} = 20 \text{ mA}$ , $U_{max} = 30 \text{ V}$ , $U_{CE sat}$ for $20 \text{ mA} < 1 \text{ V}$	
Ready	This output indicates that the MSD MINI POWERPACK module is ready to operate.	
Error	This common error output is opened if an error signal occurs.	
Ambient temperature	0 to 40 °C	
Max. heat sink temperature	+85 °C	
Integrated fan	Temperature-controlled If the heat sink temperature rises > approx. 65 °C, the fan goes ON. If the temperature drops below approx. 50 °C, the fan is automatically turned OFF.	
Max. motor cable length	50 m	
Min. motor cable area	1,5 mm <sup>2</sup>	
Connector	I/O signals	25-pole D-SUB socket
Screw terminals	Motor	7-pole Phoenix screw terminals DMKDS 2,5
	Mains	5-pole Phoenix screw terminals DMKDS 2,5
Weight, including front panel	approx. 7 kg	approx. 9 kg



Description

1.2.2 Dimensions - MSD MINI 172-70 POWERPACK

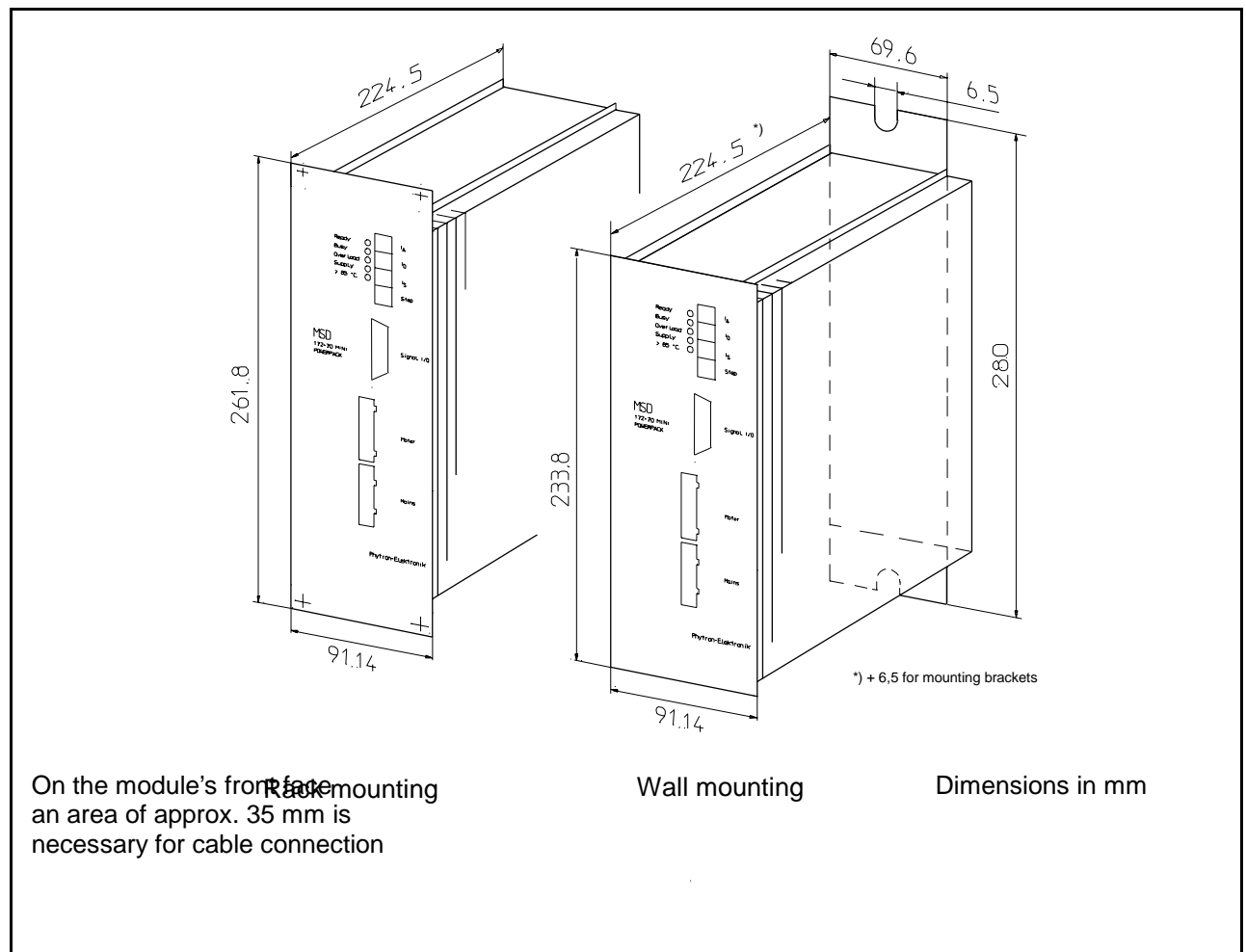

Fig. 2: Dimensions - MSD MINI 172-70 for wall or rack mounting

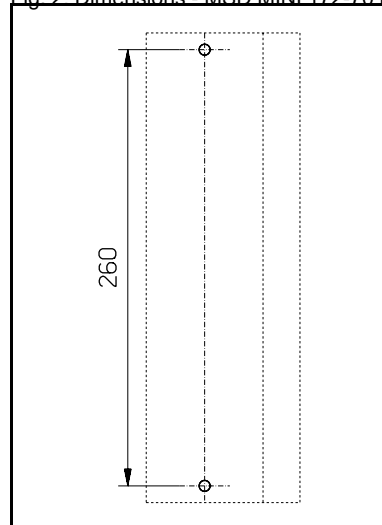

Fig. 3: Mounting holes

**Mounting instructions**

The modules must be mounted to allow correct air circulation. Vertical mounting provides better ventilation.

**Wall mounting**

The MSD MINI 172-70 POWERPACK wall mounting version is delivered with removable mounting brackets. The mounting holes must be drilled at a 260 mm distance.

**Rack mounting**

The front panel of the MSD MINI 172-70 POWERPACK 19"-rack mounting version is 6 U high and 18 F wide.

Description

1.2.3 Dimensions - MSD MINI 172-140 POWERPACK

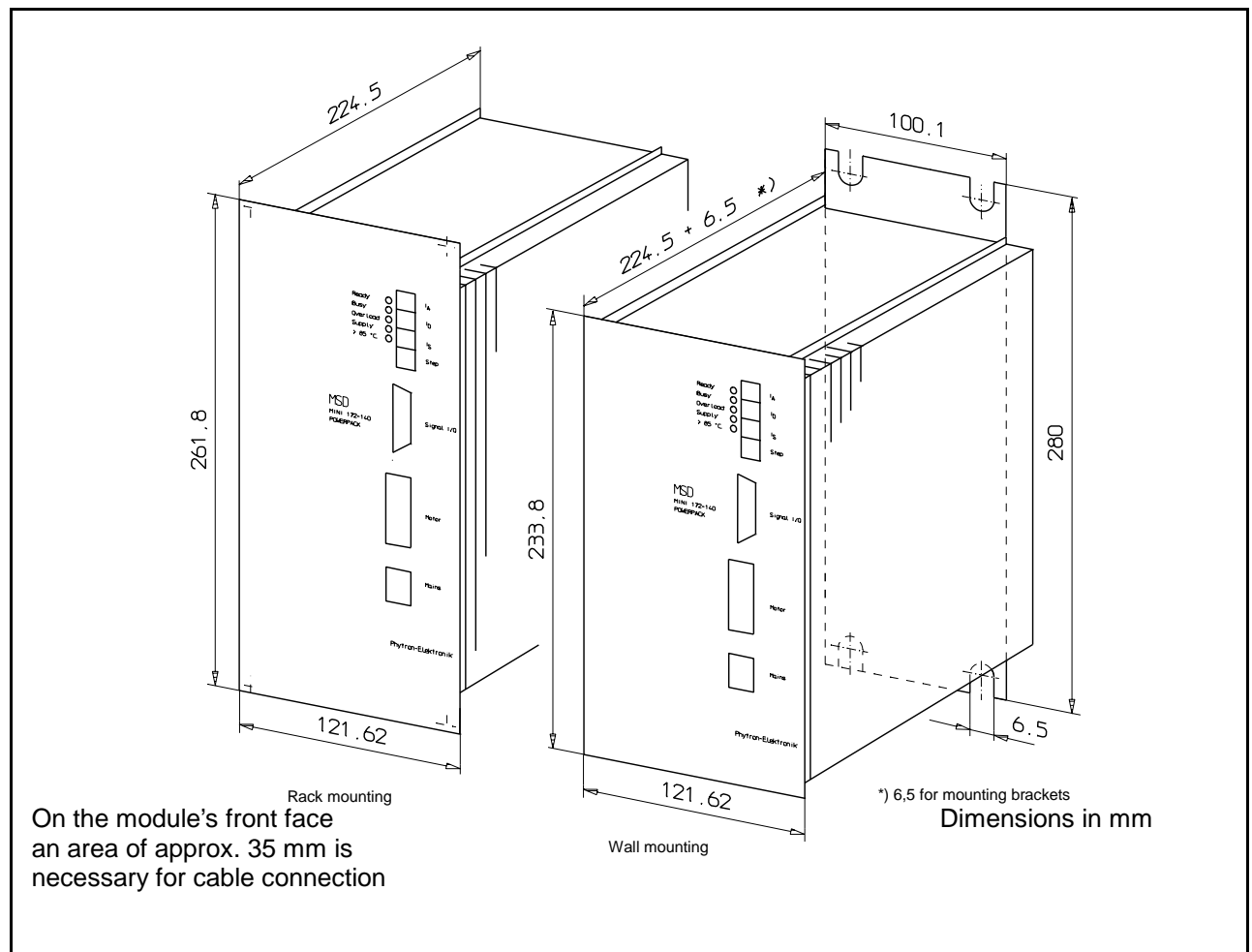

Fig. 4: Dimensions - MSD MINI 172-140 for wall or rack mounting

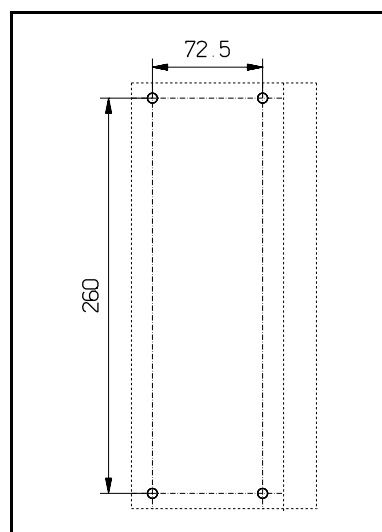

Fig. 5: Mounting holes

**Mounting instructions**

The modules must be mounted to allow correct air circulation. Vertical mounting provides better ventilation.

**Wall mounting**

The MSD MINI 172-140 POWERPACK wall mounting version is delivered with removable mounting brackets. The mounting holes must be drilled according to figure 5.

**Rack mounting**

The front panel of the MSD MINI 172-140 POWERPACK 19"-rack mounting version is 6 U high and 24 F wide.

**Description**

**1.2.4 I/O connector**

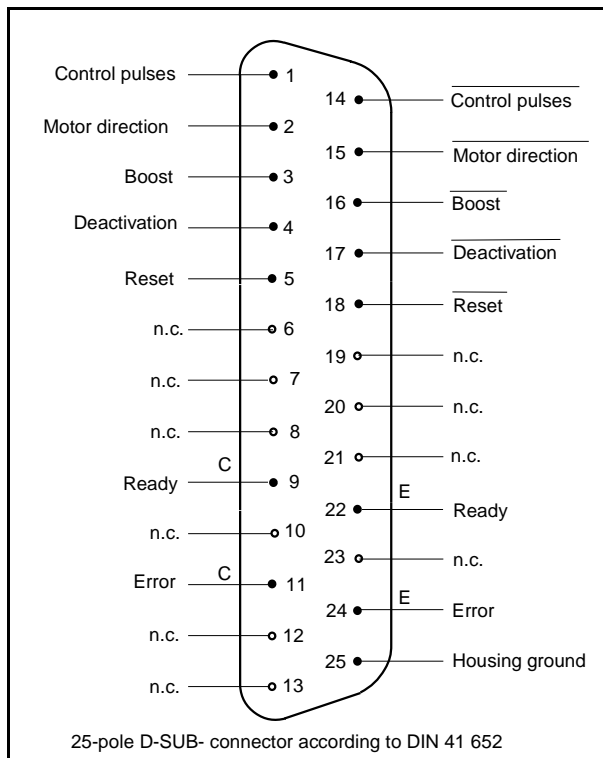

Inputs and outputs: please refer to pages 19-22.

**Attention:**  
Use shielded cables only !

Fig. 6: MSD MINI POWERPACK signal connector

Description

1.2.5 Connection to type SPS control units

As the MSD MINI POWERPACK power stages are equipped with galvanically separated inputs and outputs, they can be connected to any control unit equipped with a stepper motor interface. The example below shows the cable connections to type **IP 267** and **IP 247** control units.

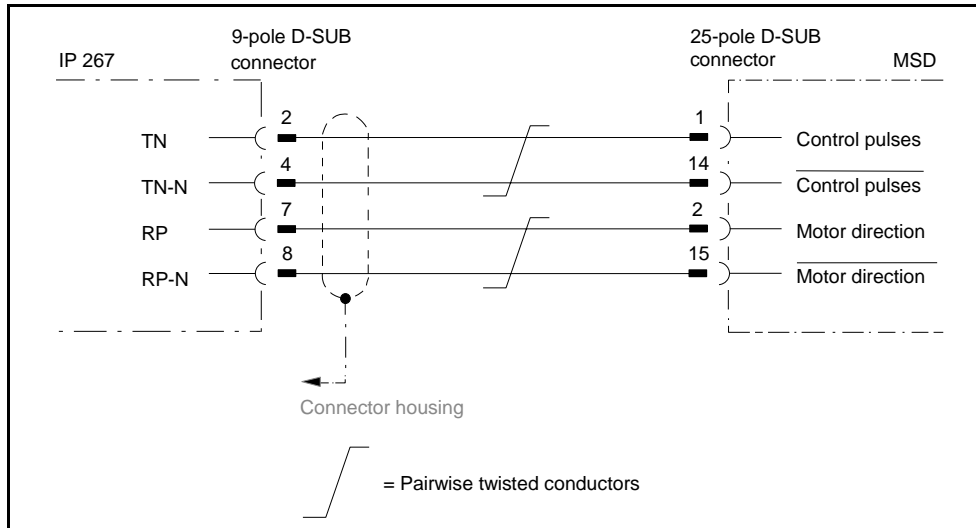

Fig. 7: IP 267 → MSD MINI POWERPACK cable connection

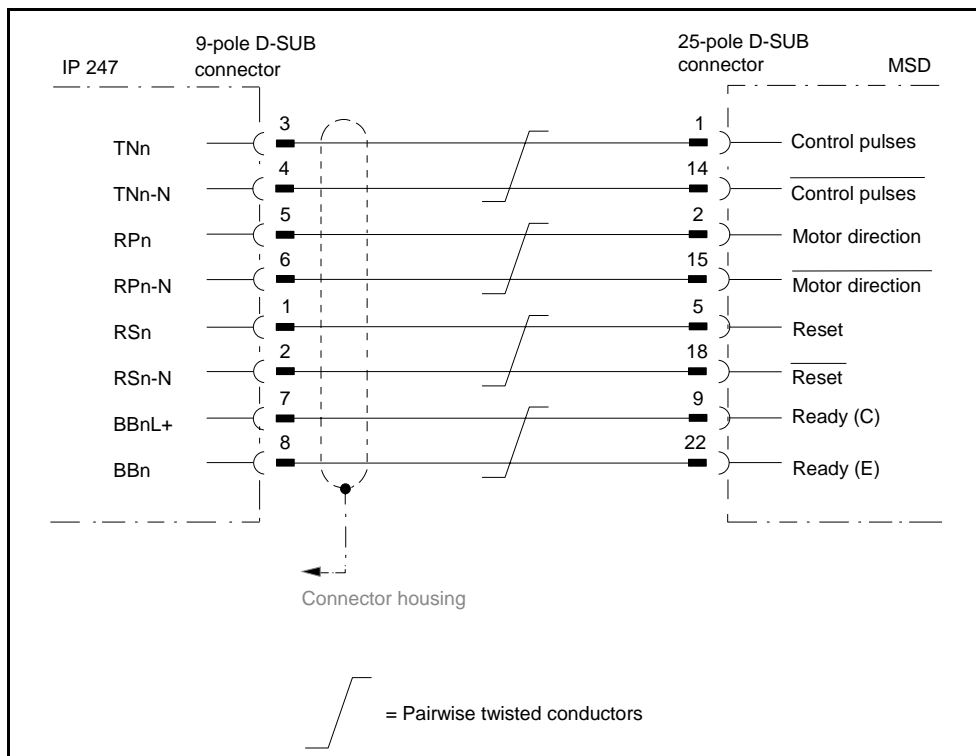
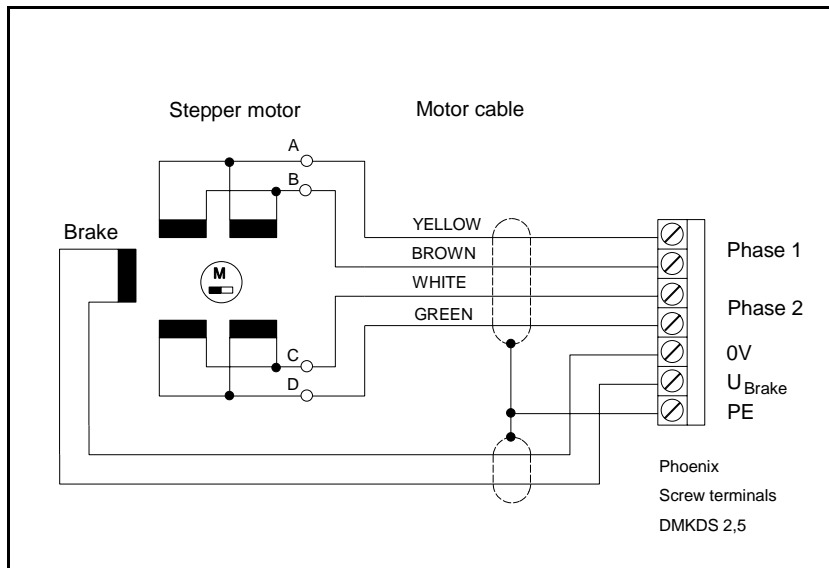

Fig. 8: IP 247 → MSD MINI POWERPACK cable connection

Description

1.2.6 Screw terminal motor connection



**Important remarks:**

When connecting the shielded motor cables to the screw terminals, the contact resistance must be as low as possible.

Therefore, to connect the motor, either

- finestrans cables without crimp terminals
- or wire equipped with crimp terminals according to DIN EN 50 027

should be used.

Fig. 9: MSD MINI POWERPACK - Motor connection with brake (option)

MSD MINI 172-140 special version without setting switches: motor connection is described on page 26.

1.2.7 Screw terminal mains connection

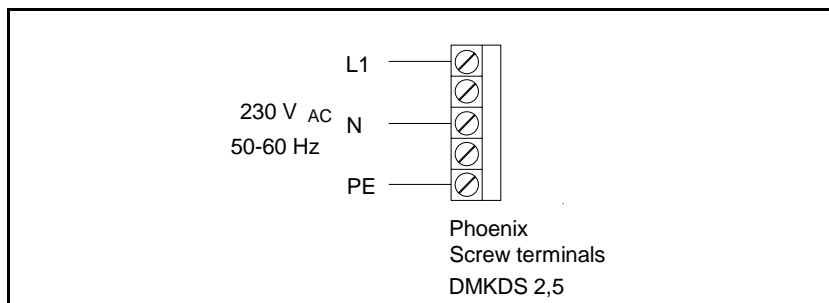

Fig. 10: Mains connection 230 V<sub>AC</sub>

Description

1.3 Description of operation

The MSD MINI POWERPACK stepper motor power stage wiring diagram can be divided into three zones:

- the power stage, including power transistors, drivers, current regulators and a special IC performing the overall regulation functions.
- the supply module which generates the internal service voltages
- the supply unit with switching-on current limiter, disturbance filter (EMI filter), rectifier and filtering circuits

Schematically, the operating principle of the MSD power stages consists of a current regulation of both phase currents by chopped, pulse-width modulated amplifiers synchronized with the rotating field (synchronized with the control pulses) - patented SYNCROCHOP principle developed by Phytron. The chopper frequency of the amplifiers is 20 KHz which enables noise-free stepper motor operation at a standstill.

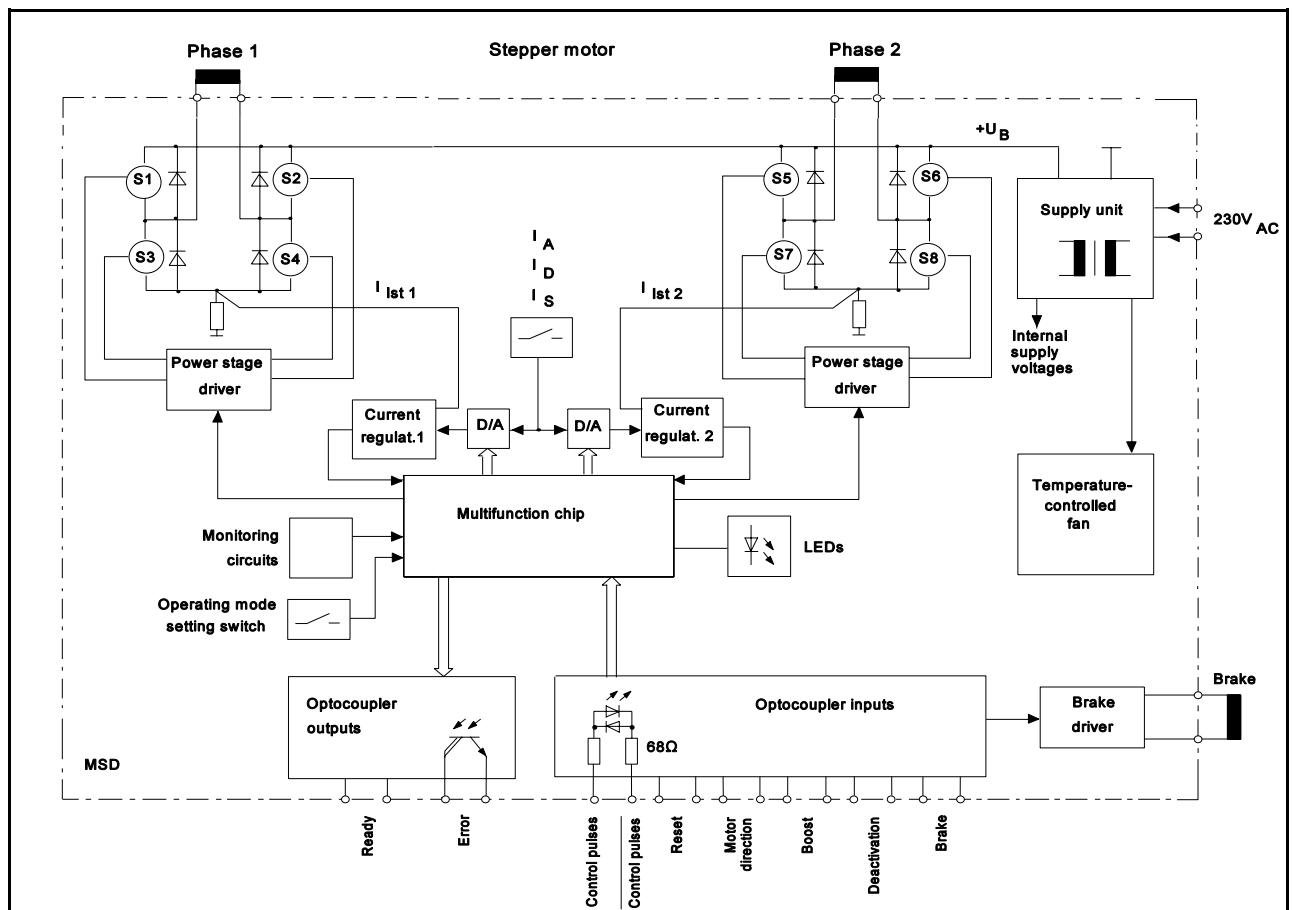

Fig. 11: Block diagram

**Description**

**1.3.1 Full step / half-step / ministep modes**

The "full step" mode is the operating mode in which a 200-step motor is driven to effect 200 steps per revolution. The full step mode always energizes both stepper motor phases.

The motor resolution can be electronically multiplied by 2 by alternately energizing the stepper motor's phases 1, 1+2, 2, etc.: this is the "half-step" mode. However, compared to the full step mode, the half-step mode reduces the output torque. Therefore, Phytron has developed a "half-step mode with torque compensation": as long as the motor phases are energized, the current is increased by  $\sqrt{2}$ . Compared to the full step mode, the torque delivered is almost the same, and the resonance of the full step mode is suppressed.

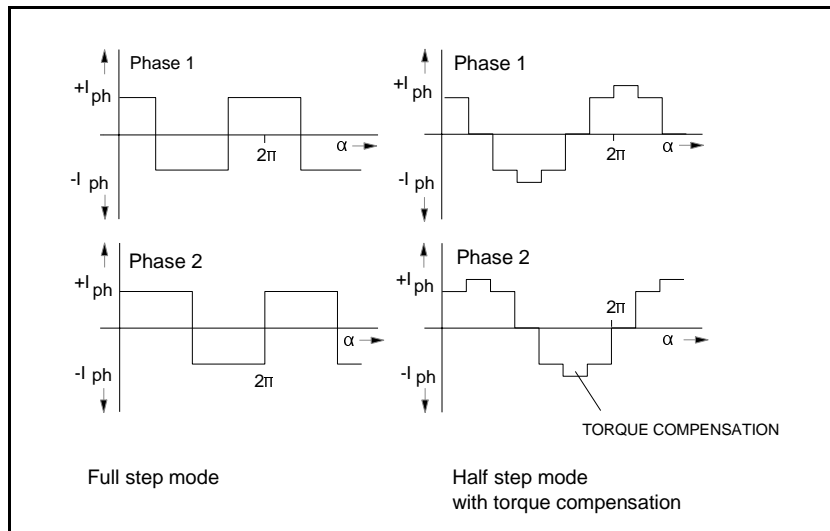

**Remark:**

The current and loss values indicated in Phytron's motor data sheets always refer to the energizing of both stepper motor phases.

Fig. 12: Phase current curves

The figure below shows the magnitude and the direction of the holding torques during one revolution of a 4-step motor, with and without torque compensation.

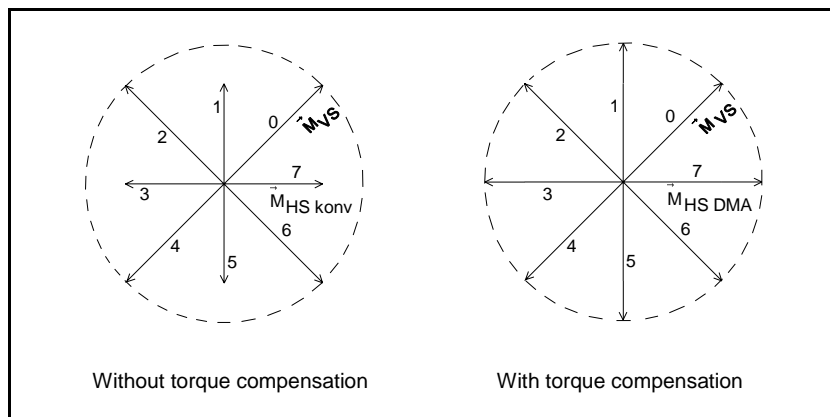

In the full step mode, both phases are energized, in the half-step mode, only one phase is energized. The total moment is the result of superpositioning both phase moments.

The moment in the full step mode,  $M_{VS}$ , as compared to the moment in the half-step mode,  $M_{HS}$ , is:

$$|M_{VS}| = |M_{HS}| \cdot \sqrt{2}$$

Fig. 13: Holding torques without/with torque compensation

This means, when a single phase is energized, the current must be increased by a  $\sqrt{2}$  factor to obtain an identical torque.

When used in the "ministep mode", the MSD MINI POWERPACK power stages furthermore increase the step

**Description**

resolution by a factor of 2½, 4, 5, 10 or 20.

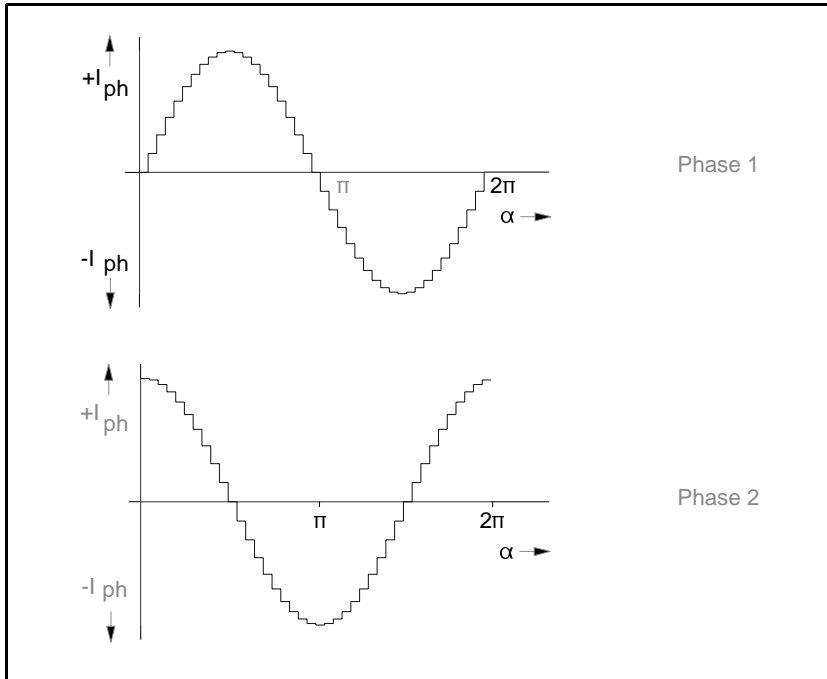

Figure 14: 1/10 Ministep

Various advantages are obtained by the almost sine-shaped ministep mode current:

- The torque undulation drops when the number of ministeps is increased.
- Resonance and overshoot phenomenae are greatly reduced ; the stepper motor operation is almost resonance-free.
- The motor noise also drops when the number of ministeps is increased.

**1.3.2 Boost**

The motor torque required during acceleration and deceleration is higher than that required during continuous motor operation ( $f_{max}$ ).



Abb. 1: Boost

For fast acceleration and deceleration settings, (steep ramps), the motor current is too high during continuous operation and results in motor overheating. However, a lower phase current results in too flat acceleration and deceleration ramps.

Therefore, different phase currents should be used for the ramps and the continuous operation of the motor.

- Continuous operation: drive or run current
- During acceleration and deceleration : Boost current

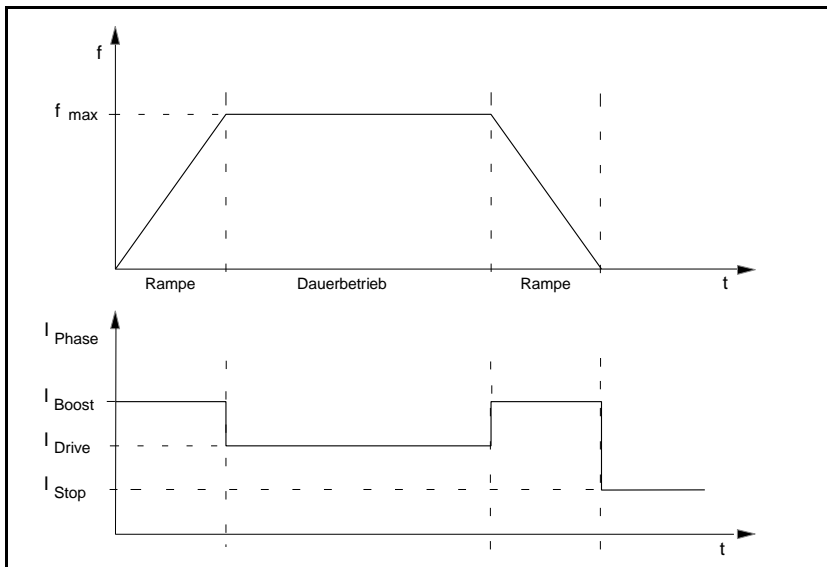
**1.3.3 Overdrive**

In addition to the standard Boost function, the MSD MINI 172-140 POWERPACK power stages include a



**Description**

dynamic Boost function: "Overdrive". This function increases the torque within the higher frequency range:

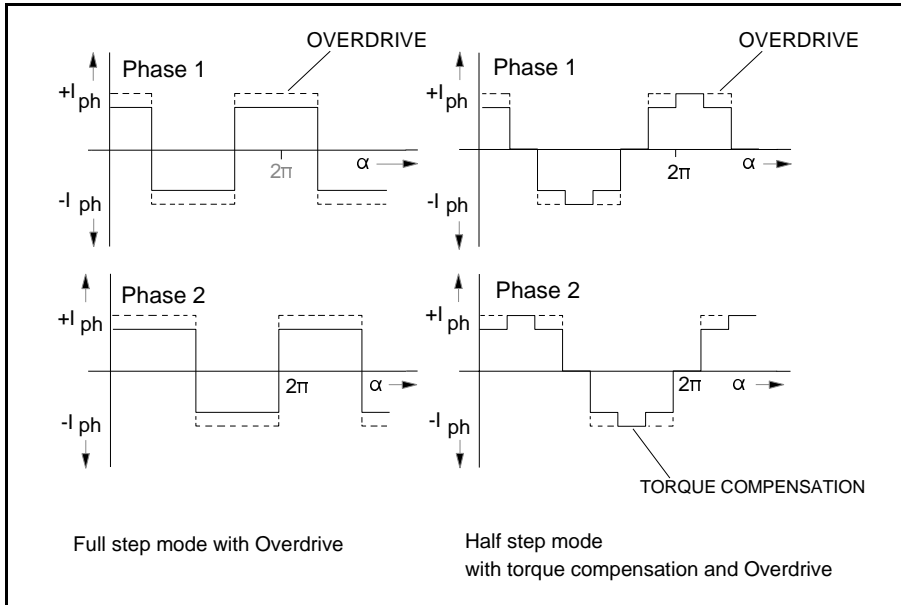

Fig. 16: Schematic curves of the phase currents with Overdrive

For control pulse frequencies above 1 KHz in the full step mode (i.e.: 300 rev./min for a 200-step motor), the Overdrive function automatically increases the phase current by 1,4.

In the ministep mode 1/n, the start frequency for the Overdrive function is n x 1 KHz.

Figure 17 shows the single phase current below and above the Overdrive start frequency, for the full step mode and the 1/10 ministep mode.

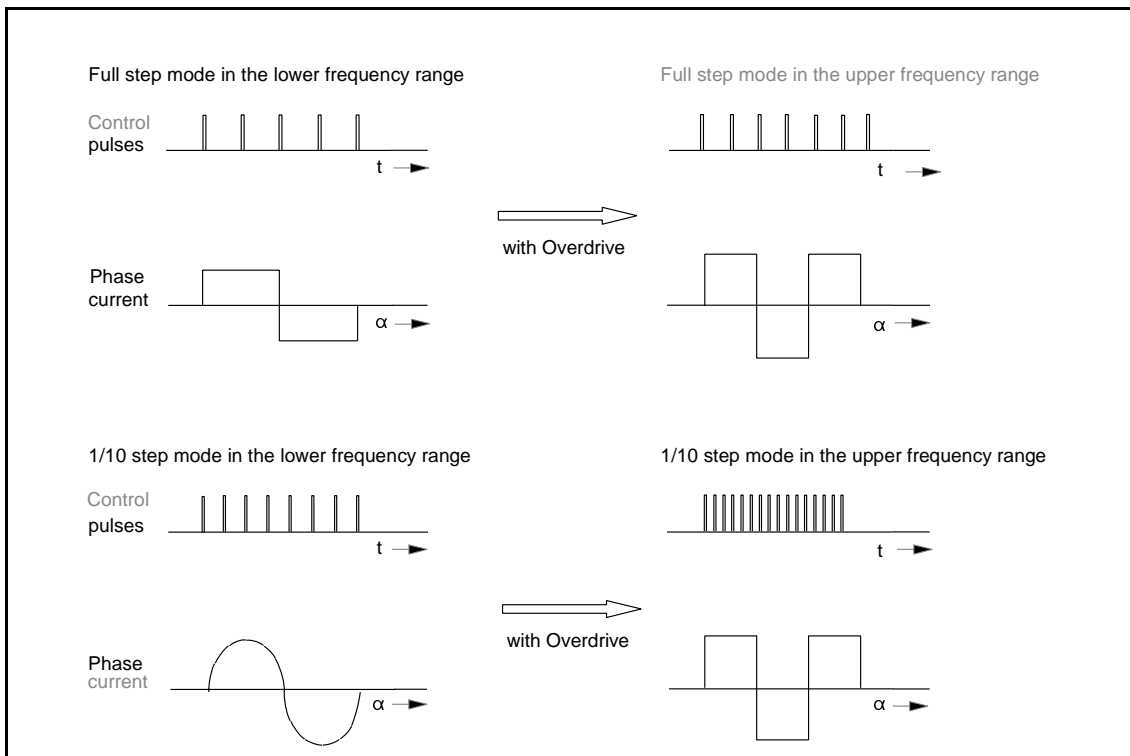

Fig 17: Single phase current below and above the Overdrive start frequency

**Description**

---

**Remark:**

Although the current profile in the ministep mode is similar to that of the full step mode, the 1/n ministep mode requires n times more control pulses to drive the motor at the same speed.

**Example:**

A 200-step motor requires, in the 1/10 ministep mode, with or without the Overdrive function, 2,000 control pulses to effect a full revolution.

**Motor connection**

**2 Motor connection**

**2.1 Connection of different types of stepper motors**

Type MSD MINI POWERPACK power stages can be used to drive various types of two-phase stepper motors.

For 8-lead stepper motors, two types of connections can be used: serial (1) or parallel (2) wiring of the motor windings.

For 6-lead stepper motors, the windings cannot be connected in parallel. It is recommended to connect these motor windings in series (3). If the motor cannot be connected as per figure (3), it can be connected with only 2 windings, as shown in (4).

It is not possible to connect 5-lead stepper motors to power stages MSD MINI POWERPACK.

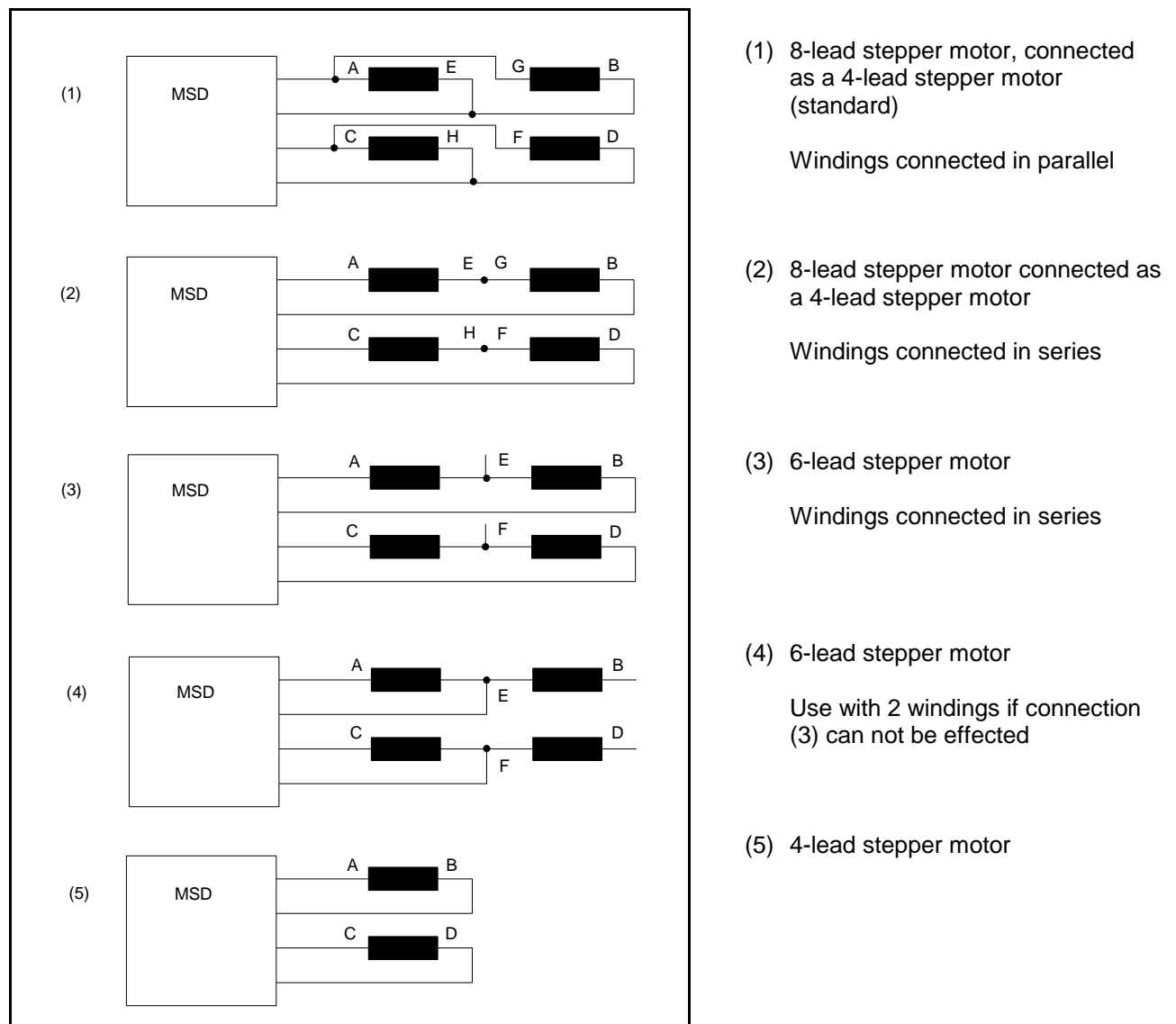

Fig. 18: Motor connection

## Motor connection

---

### 2.2 Motor cables

All motor cables must have areas of at least 1,5 mm<sup>2</sup>.

Insulate all unused motor wires individually!

### 2.3 Shielding

Perturbations affecting the wires and instruments installed close to the system should be kept as low as possible, therefore shielded cables must be used. The cable shielding must be connected at one end to the ground (PE) of the MSD MINI POWERPACK. The motor and/or mechanical system are connected to the ground by a central earthing tab.

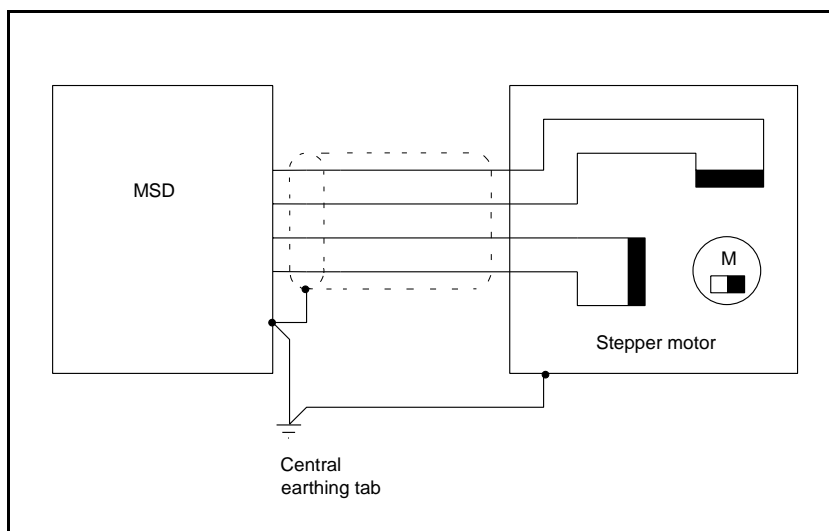

Fig. 19: Shielding

### 2.5 Motor brake

The module delivers a short-circuit protected brake supply voltage, available on the motor connector (24 V<sub>DC</sub> / 1 A max.). When the "Brake" input is active, the brake is supplied.

The permanent magnet motor brake is activated when there is no voltage supplied to the brake. The permanent magnet attracts the built-in anchor disk in the axial direction towards a friction disk and thus generates a torsion-free friction connection. When the brake is supplied, the attracting force on the anchor is neutralized. The friction surfaces in contact are separated by a riveted spring, without residual torque, whatever the mounting position.

Inputs

3 Inputs

The following inputs are protected by optocouplers: control pulse, motor direction, Boost, deactivation, Reset and motor brake. These signals are active when a current flows through the optocoupler. The differential voltage between the input and the negative signal must be above 2.5 V to ensure input activation.

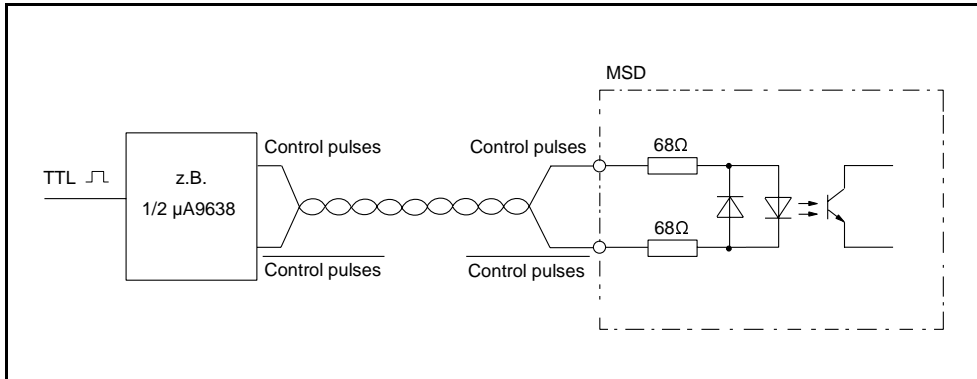

Fig. 20: RS422 type control signals

High immunity is obtained when driving the module with RS422 control signals, as these lines are permanently supplied. This type of control signal is particularly recommended for connections over long distances.

Alternately, the control signals can be of the open collector type:

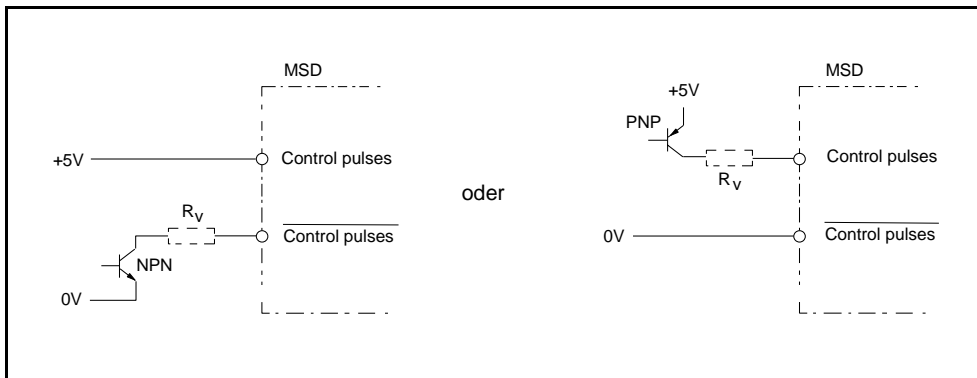

Fig. 21: Open-collector type control signals

U	R <sub>v</sub>
5 V	-
12 V	620 Ω
24 V	1.8 kΩ

Permissible supply range: 2.5 to 5 V

For supply voltages > 5 V, the current in the optocoupler must be reduced with a R<sub>v</sub> series resistor to approx. 10 mA.

3.1 Control pulses

## Inputs

---

The maximum control pulse frequency is 250 KHz.

One  $\geq 2 \mu\text{s}$  pulse causes one motor step. With the control pulse signal, the unit switches from the stop current into the drive current and the step is executed. If the time lapse between pulses is above 40 ms, the automatically switches back to the stop current. For the special MSD MINI 172-140 version without setting switches, the stop current is restored after a 500 ms lapse.

### Caution:

- If the Boost input is activated, the current set with the Boost switch will supply the motor continuously.
- The control pulses must not be interrupted suddenly for frequencies above the start-stop frequency. This would cause mispositioning.

### Remark:

The start-stop frequency is the maximum frequency at which a motor at a standstill can be started without mispositioning. Normally, the start-stop frequency ranges between 200 and 2,000 Hz. The actual value depends on the motor itself and the system connected; e.g. for large motors connected to heavy loads, this frequency is lower.

## 3.2 Motor direction +/-

This signal sets the direction of rotation for the motor: as long as this input is not activated, the motor runs in the preferential direction (programmed by switch). As soon as current flows through the optocoupler, the motor direction is reversed. This signal must only be modified when the motor is at a standstill or when it is driven with a frequency within the start-stop frequency range. This signal must not be modified during 1  $\mu\text{s}$  before and 4  $\mu\text{s}$  after the control pulse. Changing the motor direction at higher motor speeds will cause step losses and/or stop the motor.

The preferential motor direction can be changed by means of the "Step" setting switch (please refer to table on page 24).

## 3.3 Boost

When the Boost input is activated, the motor current corresponds to that set by the "Boost" switch ( $I_A$ ). Therefore, it is possible to set a Boost current higher than the drive current. During motor acceleration and deceleration, the Boost current can be activated and, therefore, a higher torque is obtained.

The Boost function is activated when a current flows through the corresponding input optocoupler.

There is no time limit for the use of the Boost function.

### Caution:

As long as the Boost input is activated, the motor runs with the Boost current set. This also applies, if the power stage is switched to the stop current.

## Inputs

---

### 3.4 Deactivation

If this input is activated, the motor current is switched off. This input is useful, for instance, during maintenance operations to switch the power stage off, without having to disconnect it physically from the mains. It is then possible to slowly rotate the motor by hand.

Never try to rotate the motor externally (by hand) at a high speed. In this case, it operates as a generator and returns energy to the power stage. The "Deactivation" input must not be used when the motor is running. "Deactivation" is also useful when highly sensitive instruments are installed close to the system. The magnetic disturbances generated by the power stage can thus be suppressed during measurements.

**Caution:**

The "Deactivation" input is not in conformance with professional emergency stop circuit requirements.

### 3.5 Reset

The Reset function resets the "Error" output as well as the following diodes:

Designation	Error signal
"Overload"	Overload
"Supply"	Motor supply voltage $U_B < 40 \text{ V}$ for MSD MINI 172-70 $U_B < 70 \text{ V}$ for MSD MINI 172-140
">85 °C"	Heat sink temperature > 85 °C

**Remark:**

When the Reset signal is suppressed, a time lapse of approx. 500 ms is necessary before the power stage returns to the "Ready" status.

### 3.6 Brake

The "Brake" input activates the supply voltage for the motor brake ( $24 \text{ V}_{\text{DC}}/1 \text{ A}$  on motor connector). This stops the brake action of the permanent magnet motor brake.

## Outputs

### 4 Outputs

The optocoupler outputs of the MSD MINI POWERPACK power stages are connected to open collector Darlington transistors.

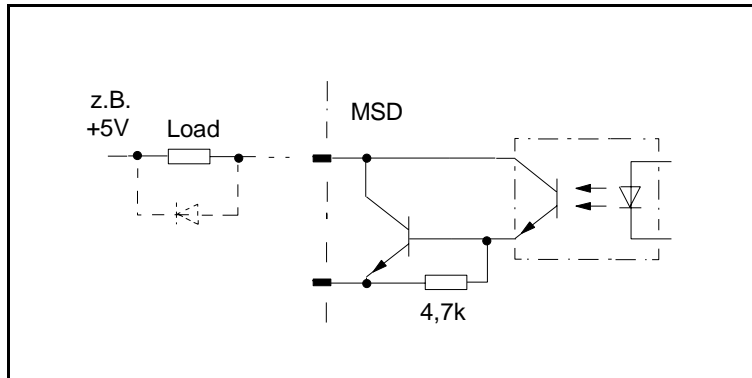

Fig. 22: Output connection

$$I_{\max} = 20 \text{ mA}$$

$$U_{\max} = 30 \text{ V}$$

$$U_{\text{CE sat}} \leq 1 \text{ V}$$

In case of connection of highly inductive equipment (e.g. a relay or motor brake), a protective (free run) diode must be connected to these outputs.

#### 4.1 Ready

The "Ready" output is activated when the MSD MINI POWERPACK power stage is ready to operate. For that, the power stage must be activated, i.e.: no signal on the "Deactivation" input.

##### Remark:

After suppression of the Reset signal, a time lapse of approx. 500 ms is necessary before the power stage delivers the "Ready" signal again.

#### 4.2 Error

The output transistor remains activated as long as there is no error signal. Therefore, power cuts or wire partings can be detected. This output is also deactivated if certain limit values are exceeded. To avoid damaging the motor, the latter is deactivated.

Limit values activating the error signal:

- Motor current > 25 A
- Motor supply voltage  $U_B < 40 \text{ V}$  (MSD MINI 172-70) or  $U_B < 70 \text{ V}$  (MSD MINI 172-140)
- Heat sink temperature > 85 °C

These error signals also light corresponding front panel red LEDs "Overload", "Supply" and "> 85 °C".

To reset the error signal, the Reset button must be activated or the mains switched off until all LEDs go out.



Front panel controls

5 Front panel controls

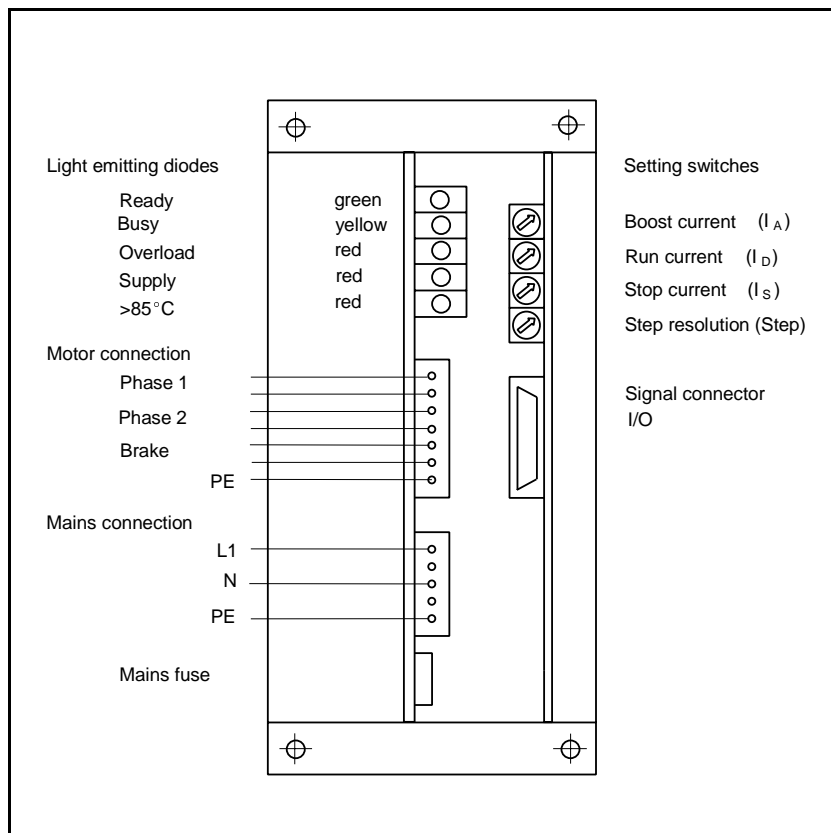

Fig. 23: Front view - front panel removed

Special version without setting switches:

The setting of the currents, motor direction, step resolution and the motor connection are described on page 26.

5.1 LEDs

LED	Color	Significance
Ready	green	MSD MINI POWERPACK is ready to operate and activated.
Busy	yellow	MSD MINI POWERPACK receives control pulses from the control unit which drives it.
Overload	red	The motor current has exceeded 25 A. This has been caused by a short-circuit or another motor malfunction.
Supply	red	The motor supply voltage is below 40 V ( MSD MINI 172-70) or 70 V (MSD 172-140). This error signal can also occur if the mains voltage drops too low or in case of irregular mains frequency.
> 85 °C	red	The heat sink temperature has exceeded 85 °C.

Please, also refer to paragraphs "Ready Output" and "Error output", page 22.

Putting-Into-Service

5.2 Setting switches

The switches used to set the motor currents, step resolution and the motor direction are located at the upper right corner of the module's front panel. The special version without setting switches is described p. 26.

**Attention:** These switches must only be activated when the module is disconnected from the mains.

Switch setting	Setting switch				
	I <sub>A</sub>	I <sub>D</sub>	I <sub>S</sub>	Step	
	Boost current	Drive current	Stop current	Step resolution *)	Preferential motor direction
	A				
0	3.0	3.0	3.0	200	left
1	3.6	3.6	3.6	400	left
2	4.2	4.2	4.2	500	left
3	4.8	4.8	4.8	800	left
4	5.4	5.4	5.4	1,000	left
5	6.0	6.0	6.0	2,000	left
6	6.6	6.6	6.6	4,000	left
7	7.2	7.2	7.2	-	-
8	7.8	7.8	7.8	200	-
9	8.4	8.4	8.4	400	right
A	9.0	9.0	9.0	500	right
B	9.6	9.6	9.6	800	right
C	10.2	10.2	10.2	1,000	right
D	10.8	10.8	10.8	2,000	right
E	11.4	11.4	11.4	4,000	right
F	12.0	12.0	12.0	-	right
					-
	F	F	5	5	
Switch setting on delivery	Max. Boost current 12 A	Max. drive current 12 A	Stop current 6 A (50% of drive current)	Step resolution 2,000 Preferential motor direction: left	

\*) for a 200-step motor

- As long as the "Boost" input is activated, the motor current corresponds to that set by the "Boost" switch. If the "Boost" input is not activated, the motor current corresponds to the current set by the "drive current" or "stop current" switch.
- The stop current is normally set to approx. 40-50% of the drive current, to keep the motor temperature as low as possible (switching to the "Stop current" : refer to page 20)
- The chart values are applicable if both motor phases are energized. If only one phase is energized, the current is equal to the chart value · √2.
- Maximum current: 12.0 A · √2 = 17 A

**Putting-Into-Service**

---

**6 Putting-Into-Service**

1. Check that the mains voltage is the same as on the MSD MINI POWERPACK module's identification plate.
2. All connectors and screw terminals must only be connected or removed when the module is disconnected from the mains.
3. The setting switches must only be activated when the module is disconnected from the mains.
4. If the motor stops during acceleration, reduce the acceleration and/or maximum frequency values. This problem may also be caused by incorrect programming of the motor's rated current.
5. If the motor gets too hot, the motor current has probably been set too high. Excessive motor heating may also be caused by continuous use of the Boost function.
6. If the motor has high resonance effects, select a higher step resolution. This may also be reduced by modifying the control pulse frequency or the acceleration or by reducing the motor current.
7. If the motor does not position correctly, there can be disturbances received on the control pulse input. Check also for excessive acceleration and deceleration values. Please, refer to the remark on page 20.
8. If the power stage does not return to the stop current, when the motor is at a standstill, this is probably caused by the Boost input activation. In this case, the motor is always supplied with the set Boost current. Deactivate the Boost input.

Accessories / Special versions**7 Accessories**

- The module is delivered with:  
Mating connector to the signal connector (25-pole D-SUB according to DIN 41652)
- Other accessories:  
Cable assembly for the mains, motor and control signal connection.

**8 Special versions**

Type	Modifications as compared to the standard version		
<b>MSD MINI 172-70-115</b>	Supply voltage	115 V <sub>AC</sub>	
	Mains fuse	6.3 A slow	
	Consumption	6 A max.	
<b>MSD MINI 172-140 without setting switches</b>	Preset values for boost current, drive current, stop current, step resolution and preferential motor direction		
	Boost current I <sub>A</sub>	13 A	
	Drive current I <sub>D</sub>	13 A	
	Stop current I <sub>S</sub>	6.3 A	
	Step resolution Preferential motor direction	1,000 (= 1/5 step) left	
	If the time lapse between two control pulses exceeds 500 ms, the module switches automatically to the stop current.		
	Motor connection	1	Phase 1
		3	
		2	Phase 2
		4	
For reasons of electromagnetic compatibility, this instrument is equipped with a metallic strain-release offering a wide contact surface for the cable shielding.			

**Quality Assurance System**

---

**9 Quality Assurance System**

To ensure a high and homogenous quality of the modules and instruments we deliver, we have set up a quality assurance system according to DIN/ISO 9001.

Each product is fully checked and effects a test run before shipment.

To avoid long term defects due to ESD (electro-static discharge) of sensitive components, a great many ESD protective measures have been taken during manufacturing process - from the acceptance tests on arrival up to the shipment of the final product.

**Important remarks:**

Respect ESD protective measures while handling sensitive parts and components (e.g. according to CECC 00 015, Edition 1).

Only ship the modules and units in packaging adapted to ESD protection.

Defects due to incorrect handling or improper packaging during transportation will not be covered by our warranty.

QS 8/94

## Index

**10 Index****A**

Accessories .....	26
Ambient temperature .....	6

**B**

Boost .....	14, 20
Brake .....	18, 21

**C**

Code switches .....	24
Connection .....	9, 11
Connections .....	17
Control pulses .....	20
Control unit connection .....	10
Control connector .....	9

**D**

Deactivation .....	21
Default .....	22
Dimensions .....	7, 8
Diodes .....	23
Drive current .....	24
Duty cycle .....	5

**E**

Error signals .....	22
Error .....	22
ESD protection .....	27

**F**

Fan .....	6
Full step mode .....	13
Fuse .....	5

**H**

Half-step mode .....	13
Heat sink temperature .....	6

**I**

Inductivity .....	5
Input .....	19

**L**

LEDs .....	23
------------	----

**M**

Mains connector .....	11
Ministep mode .....	14
Motor connection .....	11
Motor connection .....	17
Motor direction .....	20
Motor cables .....	18
Mounting holes .....	7, 8
Mounting brackets .....	7, 8
Mounting instructions .....	7, 8

**O**

Open collector .....	19
Output .....	22
Overdrive .....	15, 16

**P**

Preferential motor direction .....	20
Putting into operation .....	25

**Q**

Quality assurance system .....	27
--------------------------------	----

**R**

Ready .....	22
Reset .....	21
RS422 .....	19
Run current .....	24

**S**

Setting switches .....	24
Shielding .....	18
Special versions .....	26
Stepper motor types .....	5, 17
Stop current .....	24
Supply voltage .....	5
Switches .....	24

**T**

Technical characteristics .....	5
Torque compensation .....	13

**W**

Weight .....	6
--------------	---



**Phytron GmbH • Industriestraße 12 • 82194 Gröbenzell, Germany**  
**Tel. +49(0)8142/503-0 • Fax +49(0)8142/503-190 • E-Mail [info@phytron.de](mailto:info@phytron.de) • [www.phytron.de](http://www.phytron.de)**

**Phytron, Inc. • 600 Blair Park Road, Suite 220 • Williston, VT, 05495 USA**  
**Tel. +1-802-872-1600 • Fax +1-802-872-0311 • Email [info@phytron.com](mailto:info@phytron.com) • [www.phytron.com](http://www.phytron.com)**