

TXM24 Ethernet

Integrated Step-Servo Motor



Hardware Manual

920-0089

Rev. C



Contents

1	Introduction	3
1.1	Features	3
1.2	Block Diagram	4
1.3	Safety Instructions	5
2	Getting Started.....	6
2.1	Installing Software	6
2.2	Mounting the Hardware	6
2.3	Choosing a Power Supply	7
2.3.1	Voltage	7
2.3.2	Regeneration Clamp	7
2.3.3	Current	8
3	Installation/Connections.....	11
3.1	Connecting the Power Supply	11
3.2	Connecting the TXM24 Communications.....	12
3.2.1	Connecting to the PC using Ethernet.....	12
3.3	Connecting the Drive to Your PC using Ethernet	13
3.3.1	Addresses, Subnets, and Ports	13
3.3.2	Option 1: Connect a Drive to Your Local Area Network.....	14
3.3.3	Option 2: Connect a Drive Directly to Your PC.....	15
3.3.4	Option 3: Use Two Network Interface Cards (NICs).....	16
3.4	Inputs and Outputs	17
3.4.1	Connector Pin Diagram	17
3.4.2	STEP & DIR Digital Inputs.....	18
3.4.3	EN Digital Input	19
3.4.4	AIN Input.....	20
3.4.5	Programmable Output	21
4	Troubleshooting	22
5	Reference Materials.....	23
5.1	Torque-Speed Curves	23
5.2	Mechanical Outlines	24
5.3	Technical Specifications	25
5.4	Accessories	26
6	Contacting Applied Motion Products.....	26

1 Introduction

Thank you for selecting the Applied Motion Products TXM24 Integrated Motor. The TXM line of integrated step-servo motors combines servo technology with an integrated motor to create a product with exceptional feature and broad capability. We hope our commitment to performance, quality and economy will result in a successful motion control project.



1.1 Features

- Programmable, Digital servo driver and motor in an integrated package
- Operates from a 12 to 70 volt DC power supply
- Control Modes:
 - Torque Control
 - * Analog input
 - * SCL commanded
 - Velocity Control
 - * Digital input Control Velocity
 - * Analog velocity
 - * SCL Commanded Velocity (Jogging)
 - Position Control
 - * Digital Signal type
 - Step & Direction
 - CW & CCW pulse
 - A/B Quadrature (Encoder Following)
 - * Analog Position
 - * Serial Commanded Position
 - Q Programming(Q Version only)
 - * Stand alone operation
- Communications:
 - * Ethernet UDP/TCP, EtherNet/IP
- 5000 line (20,000 counts/rev) encoder feedback
- Available torque:
 - * TXM24S/Q/IP-3EG: Up to 2.4N•m Continuous (3.0 N•m Boost)
 - * TXM24S/Q/IP-1EG: Up to 0.82N•m Continuous (1.03N•m Boost)
- I/O:
 - 3 optically isolated digital inputs, with adjustable bandwidth digital noise rejection filter, 5 to 24 volts
 - 1 optically isolated digital output, 30V/100 mA max.
 - 1 analog input for speed and position control, 0 to 5 volts
- Technological advances:
 - Full servo control, Closed loop
 - Efficient, Accurate, Fast, Smooth
 - Intelligent, Compact
- IP65 protected with three M12 connectors.

1.2 Block Diagram

TXM24 Ethernet
Block Diagram

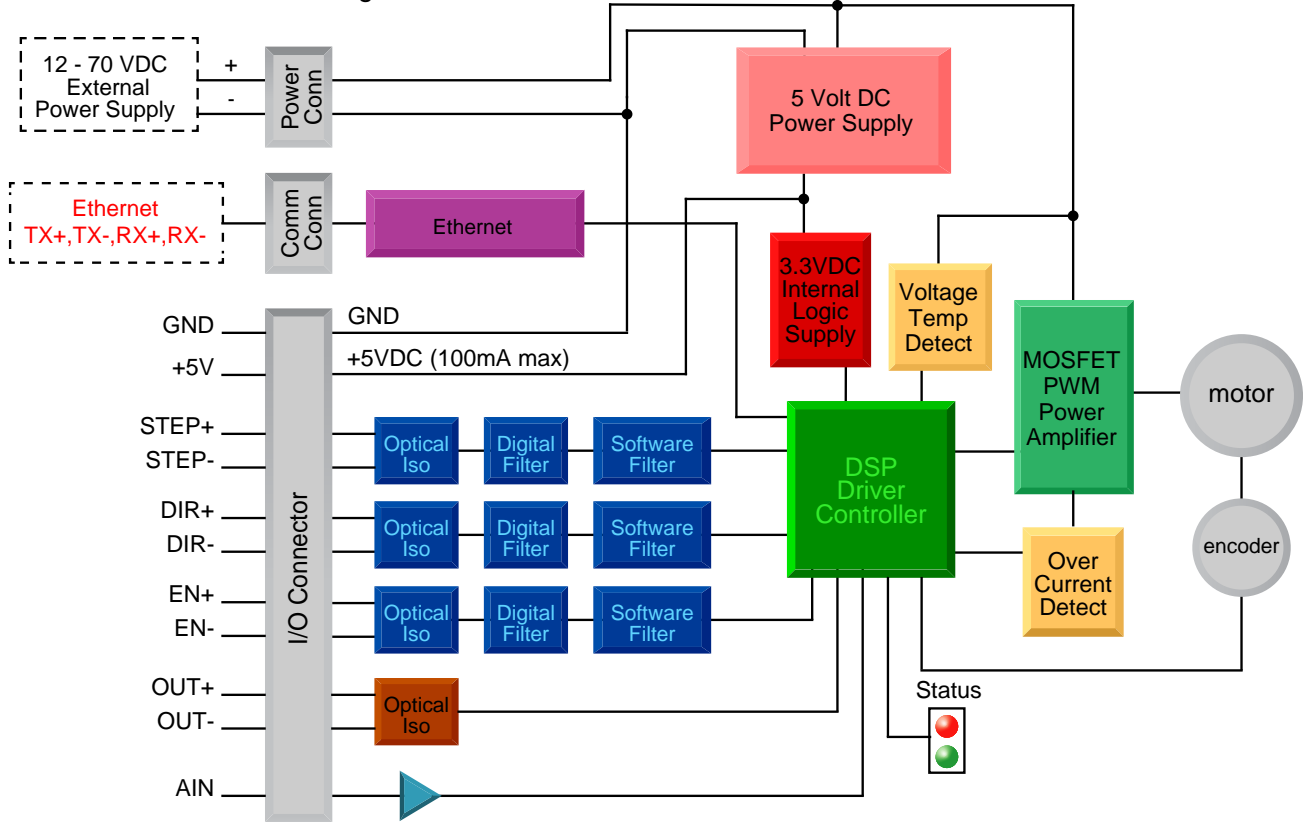

I/O Configurations

STEP (5 to 24 volts)	DIR (5 to 24 volts)	EN (5 to 24 volts)	OUT (30V, 100mA)
Step	Direction	Enable	Fault
CW step	CCW step	Alarm/fault reset	Motion
A quadrature (encoder following)	B quadrature (encoder following)	Speed 1/speed 2 (oscillator mode)	Tach
CW limit	CCW limit	General purpose input	In position
CW jog	CCW jog		Brake
Start/stop (oscillator mode)	Direction (oscillator mode)		General purpose programmable
General purpose input	General purpose input		

1.3 Safety Instructions

Only qualified personnel should transport, assemble, install, operate, or maintain this equipment. Properly qualified personnel are persons who are familiar with the transport, assembly, installation, operation, and maintenance of motors, and who meet the appropriate qualifications for their jobs.

To minimize the risk of potential safety problems, all applicable local and national codes regulating the installation and operation of equipment should be followed. These codes may vary from area to area and it is the responsibility of the operating personnel to determine which codes should be followed, and to verify that the equipment, installation, and operation are in compliance with the latest revision of these codes.

Equipment damage or serious injury to personnel can result from the failure to follow all applicable codes and standards. Applied Motion Products does not guarantee the products described in this publication are suitable for a particular application, nor do they assume any responsibility for product design, installation, or operation.

- Read all available documentation before assembly and operation. Incorrect handling of the products referenced in this manual can result in injury and damage to persons and machinery. All technical information concerning the installation requirements must be strictly adhered to.
- It is vital to ensure that all system components are connected to earth ground. Electrical safety is impossible without a low-resistance earth connection.
- This product contains electrostatically sensitive components that can be damaged by incorrect handling. Follow qualified anti-static procedures before touching the product.
- During operation keep all covers and cabinet doors shut to avoid any hazards that could possibly cause severe damage to the product or personal health.
- During operation, the product may have components that are live or have hot surfaces.
- Never plug in or unplug the Integrated Motor while the system is live. The possibility of electric arcing can cause damage.

Be alert to the potential for personal injury. Follow recommended precautions and safe operating practices emphasized with alert symbols. Safety notices in this manual provide important information. Read and be familiar with these instructions before attempting installation, operation, or maintenance. The purpose of this section is to alert users to the possible safety hazards associated with this equipment and the precautions necessary to reduce the risk of personal injury and damage to equipment. Failure to observe these precautions could result in serious bodily injury, damage to the equipment, or operational difficulty.

2 Getting Started

The following items are needed:

- a 12 - 70 volt DC power supply, see the section below entitled “Choosing a Power Supply” for help in choosing the right one
- a PC running Microsoft Windows XP, Vista, or Windows 7 or 8

2.1 Installing Software

Before utilizing the TXM24 Integrated Step-Servo Motor and Step-Servo Quick Tuner Software in an application, the following steps are necessary:

- Download and install the Step-Servo Quick Tuner software from Applied Motion Products website.
- Connect the drive to the PC using the Ethernet communication cable.
- Connect the drive to the power supply. See instructions below.
- Launch the software by clicking Start...Programs...Applied Motion Products...Step-Servo Quick Tuner
- Apply power to the drive.

2.2 Mounting the Hardware

As with any step motor, the TXM24 must be mounted so as to provide maximum heat sinking and airflow. Keep enough space around the Integrated Motor to allow for airflow.



- Never use the drive where there is no airflow or where other devices cause the surrounding air to be more than 40°C (104°F).
- Never put the drive where it can get wet.
- Never use the drive where metal or other electrically conductive particles can infiltrate the drive.
- Always provide airflow around the drive.

2.3 Choosing a Power Supply

The main considerations when choosing a power supply are the voltage and current requirements for the application.

2.3.1 Voltage

The TXM24 is designed to give optimum performance between 24 and 48 Volts DC. Choosing the voltage depends on the performance needed and motor/drive heating that is acceptable and/or does not cause a drive over-temperature. Higher voltages will give higher speed performance but will cause the TXM24 to produce higher temperatures. Using power supplies with voltage outputs that are near the drive maximum may significantly reduce the operational duty-cycle.

The extended range of operation can be as low as 10 VDC minimum to as high as 75 VDC maximum. When operating below 18 VDC, the power supply input may require larger capacitance to prevent under-voltage and internal-supply alarms. Current spikes may make supply readings erratic. The supply input cannot go below 10 VDC for reliable operation. Absolute minimum power supply input is 10 VDC. If the Input supply drops below 10 VDC the low voltage alarm will be triggered. This will not fault the drive.

Absolute maximum power supply input is 75 VDC at which point an over-voltage alarm and fault will occur. When using a power supply that is regulated and is near the drive maximum voltage of 75 VDC, a voltage clamp may be required to prevent over-voltage when regeneration occurs. When using an unregulated power supply, make sure the no-load voltage of the supply does not exceed the drive's maximum input voltage of 75 VDC.

2.3.2 Regeneration Clamp

If a regulated power supply is being used, there may be a problem with regeneration. When a load decelerates rapidly from a high speed, some of the kinetic energy of the load is transferred back to the power supply, possibly tripping the over-voltage protection of a regulated power supply, causing it to shut down. This problem can be solved with the use of an Applied Motion Products RC880 Regeneration Clamp. It is recommended that an RC880 initially be installed in an application. If the "regen" LED on the RC880 never flashes, the clamp is not necessary.



LEDs
Green - Power
Red - Regen on

RC880 Regen Clamp

2.3.3 Current

The maximum supply currents required by the TXM24 are shown in the charts below at different power supply voltage inputs. The TXM24 power supply current is lower than the winding currents because it uses switching amplifiers to convert a high voltage and low current into lower voltage and higher current. The more the power supply voltage exceeds the motor voltage, the less current will be required from the power supply.

It is important to note that the current draw is significantly different at higher speeds depending on the torque load to the motor. Estimating how much current is necessary may require a good analysis of the load the motor will encounter.

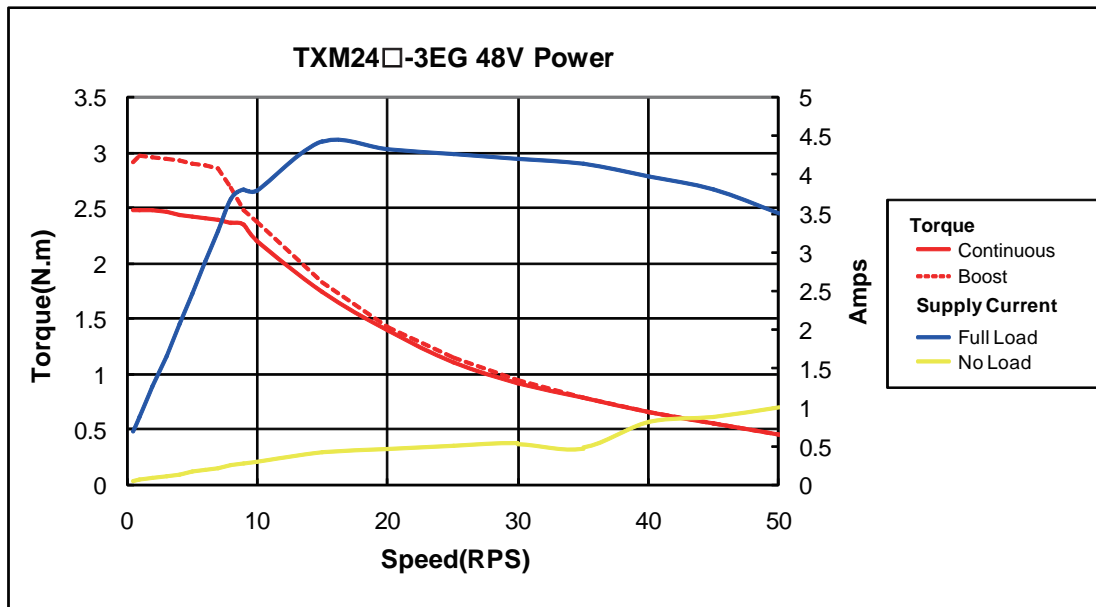
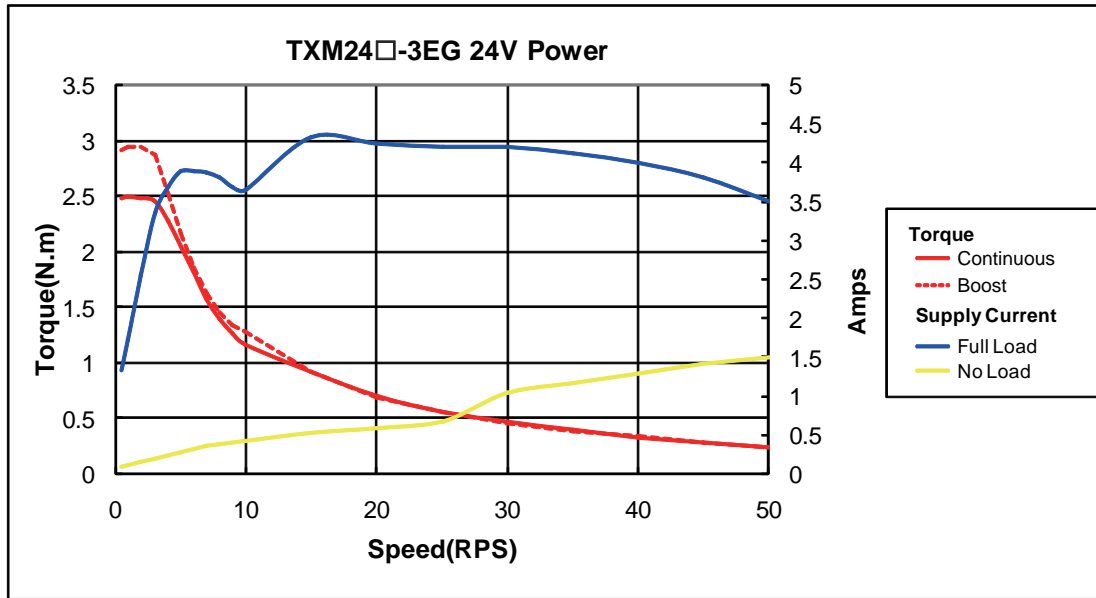

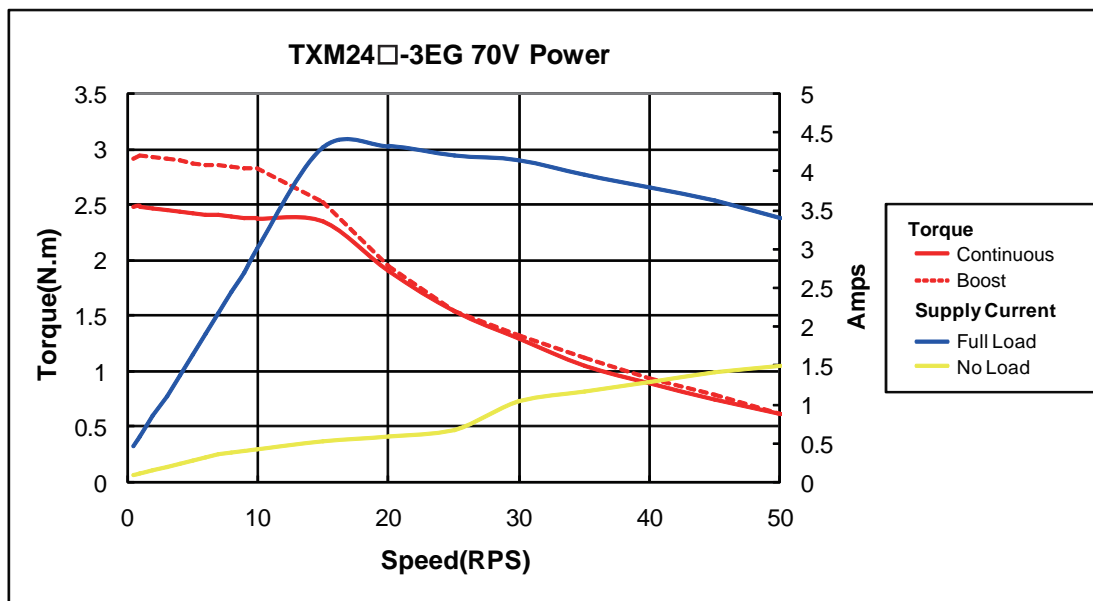

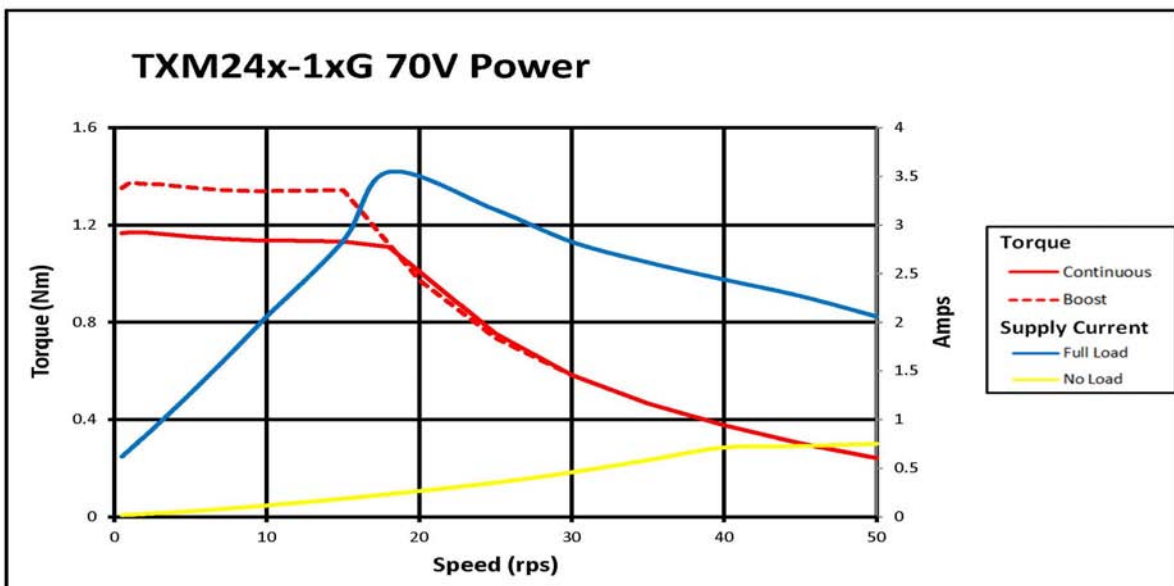
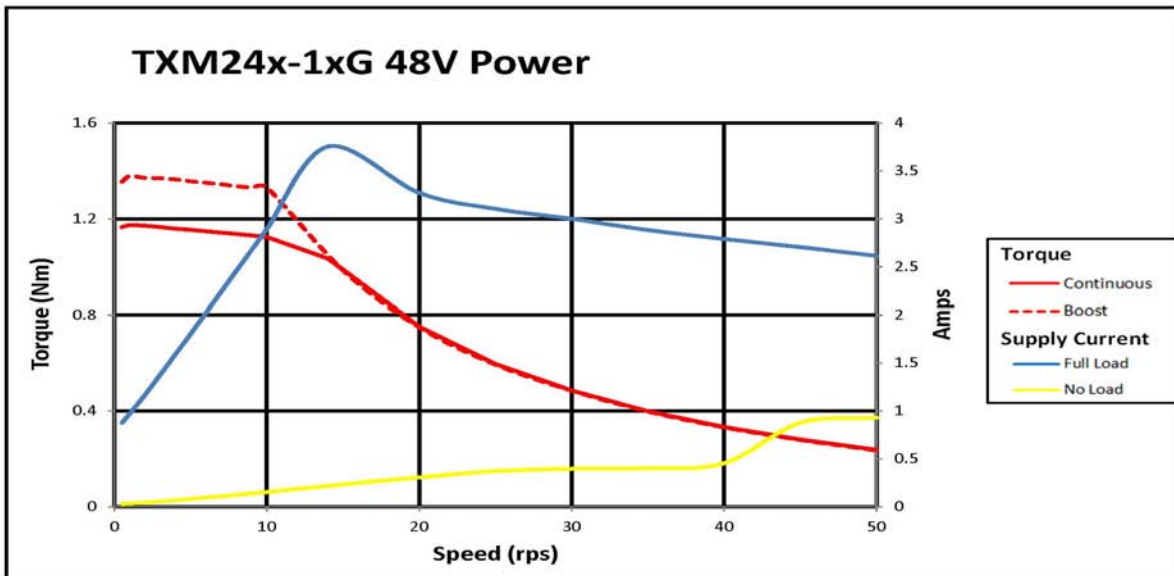
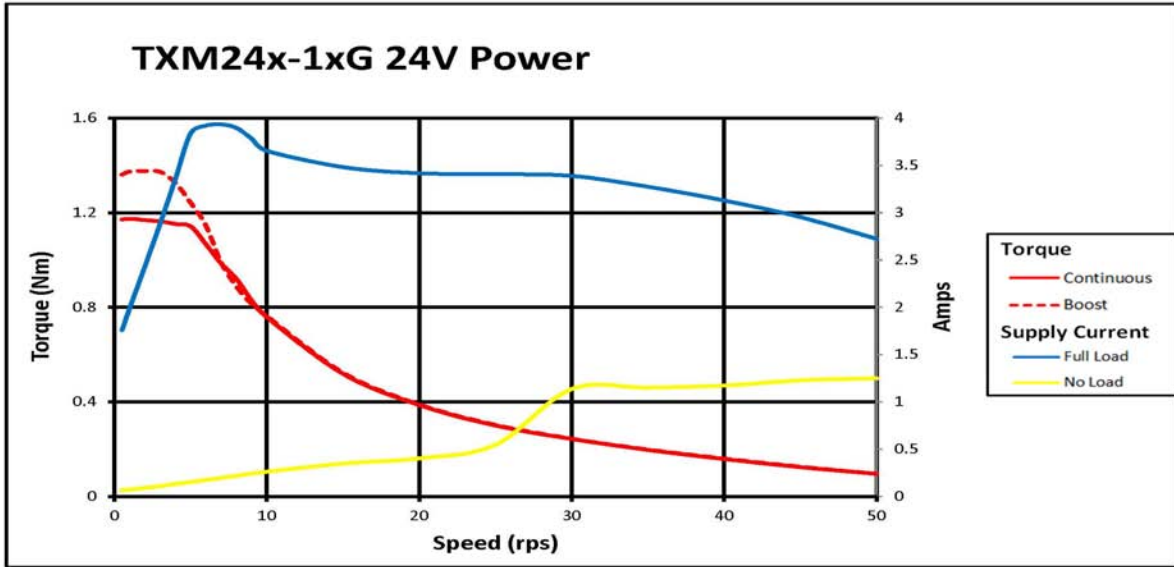

3 Installation/Connections

To meeting the IP65 protection, a suitable mating connector should be chosen.

For more information, please see the Accessories section.

3.1 Connecting the Power Supply

Use 16 to 20-gauge wire to connect the TXM24 to a power supply. It contains an internal fuse connected to the “+” terminal that is not user replaceable. If a user serviceable fuse is desired, install a 6.3 amp fast acting fuse in line with the “+” power supply lead.

Be careful not to reverse the wires. Reversing the connection may open the internal fuse on the drive and void the warranty.

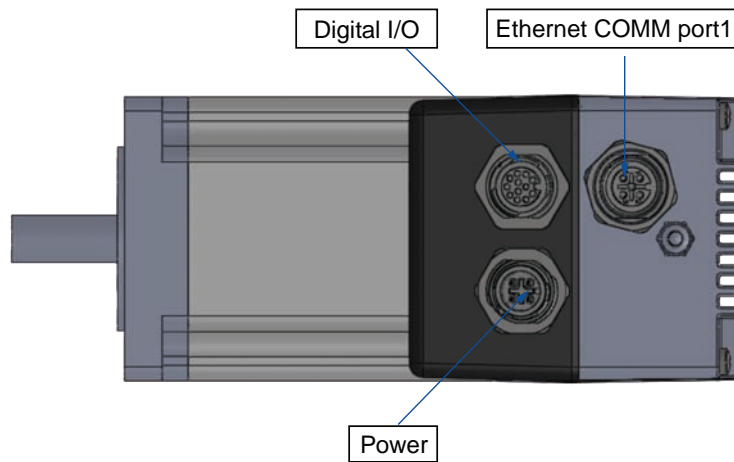

Power

Signal	Color of mating cable Phoenix P/N 1431678	Pin no.
V+	BN\BU	1\3
V-	WH\BK	2\4

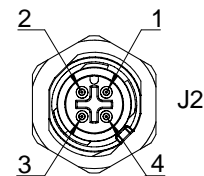

View of motor side connector

3.2 Connecting the TXM24 Communications

The communications interface for the TXM24 Ethernet is one standard 4-pin M12 connectors. The TXM24 is configured by Step-Servo Quick Tuner with Ethernet link, and then may be deployed on a distributed Ethernet network. Below are descriptions of how to interface Ethernet communication type to a PC.

3.2.1 Connecting to the PC using Ethernet

Communication port

Signal	Pin no.
TX+	1
RX+	2
TX-	3
RX-	4

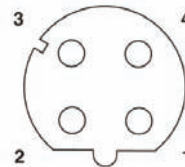

View of motor side connector 1551529

Model	Communications
	Ethernet
TXM24S-3EG, TXM24S-1EG	✓
TXM24Q-3EG, TXM24Q-1EG	✓
TXM24IP-3EG, TXM24IP-3EG	✓

3.3 Connecting the Drive to Your PC using Ethernet

This process requires three steps:

- Physically connect the drive to your network (or directly to the PC)
- Set the drive's IP address
- Set the appropriate networking properties on your PC.

3.3.1 Addresses, Subnets, and Ports

Every device on an Ethernet network must have a unique IP address. In order for two devices to communicate with each other, they must both be connected to the network and they must have IP addresses that are on the same subnet. A subnet is a logical division of a larger network. Members of one subnet are generally not able to communicate with members of another unless they are connected through special network equipment (e.g. router). Subnets are defined by the choices of IP addresses and subnet masks.

If you want to know the IP address and subnet mask of your PC, select Start...All Programs...Accessories...Command Prompt. Then type "ipconfig" and press Enter. You should see something like this:

```
Microsoft Windows XP [Version 5.1.2600]
(C) Copyright 1985-2001 Microsoft Corp.

C:\Documents and Settings\moons>ipconfig

Windows IP Configuration

Ethernet adapter Local Area Connection:

    Connection-specific DNS Suffix  . : 
    IP Address. . . . .                : 192.168.0.22
    Subnet Mask . . . . .              : 255.255.255.0
    Default Gateway . . . . .          : 192.168.0.254
```

If your PC's subnet mask is set to 255.255.255.0, a common setting known as a Class C subnet mask, then your machine can only talk to another network device whose IP address matches yours in the first three octets. (The numbers between the dots in an IP address are called octets.) For example, if your PC is on a Class C subnet and has an IP address of 192.168.0.20, it can talk to a device at 192.168.0.40, but not one at 192.168.1.40. If you change your subnet mask to 255.255.0.0 (Class B) you can talk to any device whose first two octets match yours. Be sure to ask your system administrator before doing this. Your network may be segmented for a reason.

Your drive's IP Address is stored internally in nonvolatile memory. The factory default address is 192.168.1.10. This address can be changed using our Step Servo Quick Tuner software.

If someone were to change the setting and not write it down or tell anyone then you will not be able to communicate with your drive. The only way to "recover" it is to apply power to the TXM24 with the network cable unplugged. The TXM24 will detect this condition and revert to a recovery address of 10.10.10.10. You may then connect your cable to the network and use Step Servo Quick Tuner to upload and change the stored address (using IP Table in the menu). Your PC, or any other device that you use to communicate with the drive, will also have a unique address.

Use the standard class B subnet mask (i.e. "255.255.0.0"). The mask for the recovery address is the standard class A (i.e. "255.0.0.0"). One of the great features of Ethernet is the ability for many applications to share the network at the same time. Ports are used to direct traffic to the right application once it gets to the right IP address. The UDP eSCL port in our drives is 7775. To send and receive commands using TCP, use port number 7776. You'll need to know this when you begin to write your own application. You will also need to choose an open (unused) port number

for your application. Our drive doesn't care what that is; when the first command is sent to the drive, the drive will make note of the IP address and port number from which it originated and direct any responses there. The drive will also refuse any traffic from other IP addresses that is headed for the eSCL port. The first application to talk to a drive "owns" the drive. This lock is only reset when the drive powers down.

If you need help choosing a port number for your application, you can find a list of commonly used port numbers at <http://www.iana.org/assignments/port-numbers>.

One final note: Ethernet communication can use one or both of two "transport protocols": UDP and TCP. eSCL commands can be sent and received using either protocol. UDP is simpler and more efficient than TCP, but TCP is more reliable on large or very busy networks where UDP packets might occasionally be dropped.

3.3.2 Option 1: Connect a Drive to Your Local Area Network

If you have a spare port on a switch or router and if you are able to set your drive to an IP address that is compatible with your network, and not used by anything else, this is a simple way to get connected. This technique also allows you to connect multiple drives to your PC. If you are on a corporate network, please check with your system administrator before connecting anything new to the network. He or she should be able assign you a suitable address and help you get going.

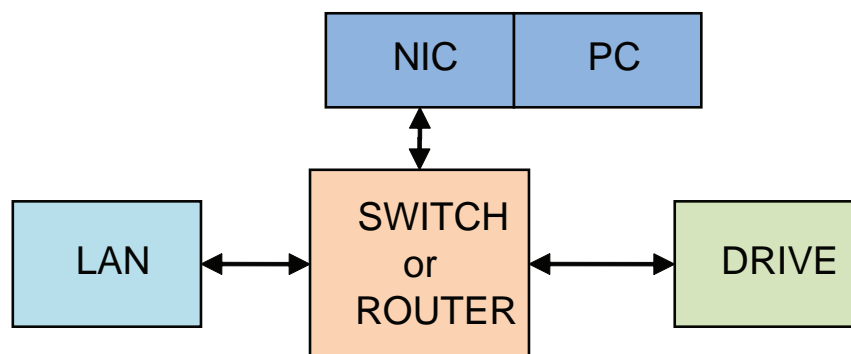

Once you've chosen an appropriate IP address for your drive, set the IP address using Step-Servo Quick Tuner. If the default address is not acceptable for your network, you can enter a new IP address using Step-Servo Quick Tuner.

If your PC address is not in 192.168.1. subnet, you will have to change your subnet mask to 255.255.0.0 in order to talk to your drive. To change your subnet mask:

1. On Windows XP, right click on "My Network Places" and select properties. On Windows 7, click Computer. Scroll down the left pane until you see "Network". Right click and select properties. Select "Change adapter settings"
2. You should see an icon for your network interface card (NIC). Right click and select properties.
3. Scroll down until you see "Internet Properties (TCP/IP)". Select this item and click the Properties button. On Windows 7 and Vista, look for "(TCP/IPv4)"
4. If the option "Obtain an IP address automatically" is selected, your PC is getting an IP address and a subnet mask from the DHCP server. Please cancel this dialog .

5. If the option “Use the following IP address” is selected, life is good. Change the subnet mask to “255.255.0.0” and click OK.

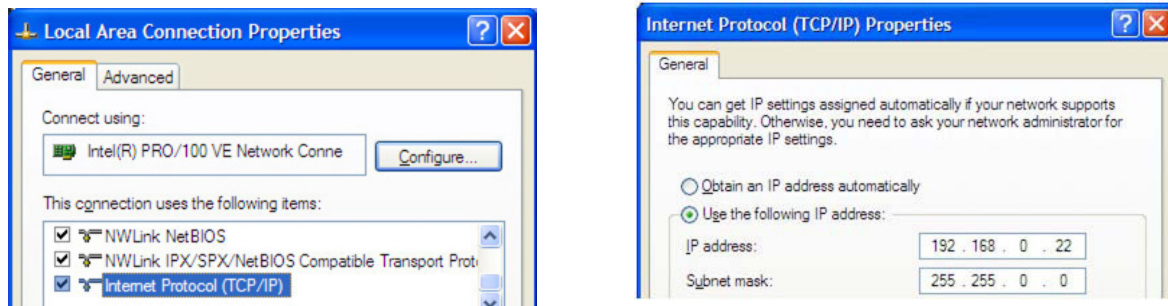

3.3.3 Option 2: Connect a Drive Directly to Your PC

It doesn't get much simpler than this:

1. Connect one end of a CAT5 Ethernet cable into the LAN card (NIC) on your PC and the other into the drive. You don't need a special “crossover cable”; the drive will automatically detect the direct connection and make the necessary physical layer changes.
2. The factory default IP address of the drive is “192.168.1.10”.
3. To set the IP address of your PC:
 - a. On Windows XP, right click on “My Network Places” and select properties.
 - b. On Windows 7, click Computer. Scroll down the left pane until you see “Network”. Right click and select properties. Select “Change adapter settings”
4. You should see an icon for your network interface card (NIC). Right click and select properties.
 - a. Scroll down until you see “Internet Properties (TCP/IP)”. Select this item and click the Properties button.
 - b. On Windows 7 and Vista, look for “(TCP/IPv4)”

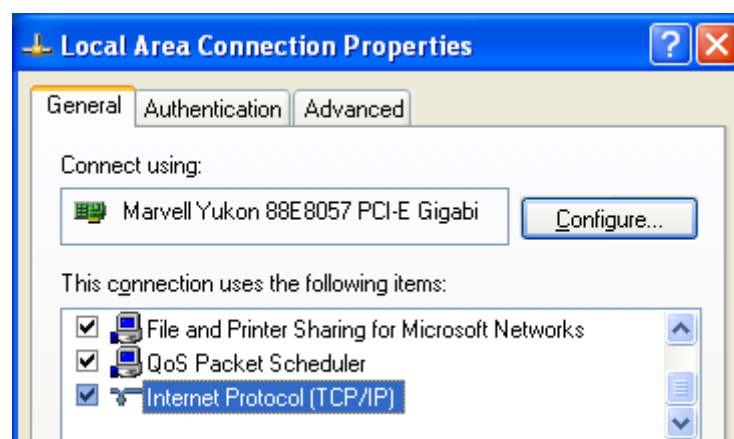

5. Select the option “Use the following IP address”. Then enter the address “192.168.1.11”. This will give your PC an IP address that is on the same subnet as the drive. Windows will know to direct any traffic intended for the drive's IP address to this interface card.
6. Next, enter the subnet mask as “255.255.255.0”.
7. Be sure to leave “Default gateway” blank. This will prevent your PC from looking for a router on this subnet.

8. Because you are connected directly to the drive, anytime the drive is not powered on your PC will annoy you with a small message bubble in the corner of your screen saying “The network cable is unplugged.”

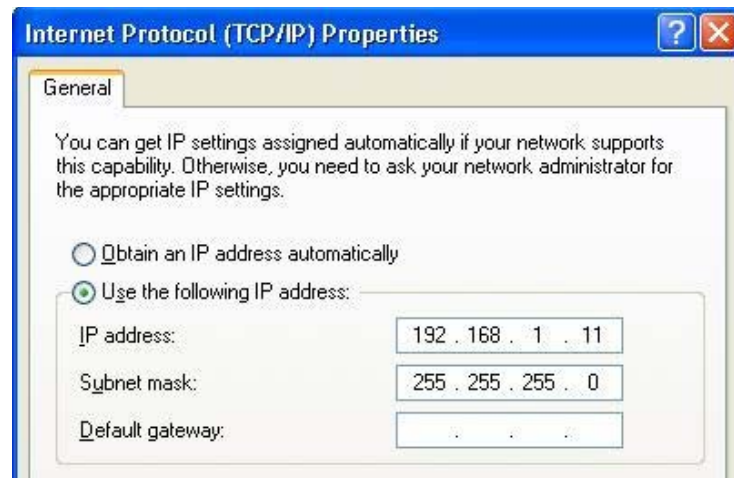

3.3.4 Option 3: Use Two Network Interface Cards (NICs)

This technique allows you to keep your PC connected to your LAN, but keeps the drive off the LAN, preventing possible IP conflicts or excessive traffic.

1. If you use a desktop PC and have a spare card slot, install a second NIC and connect it directly to the drive using a CAT5 cable. You don't need a special “crossover cable”; the drive will automatically detect the direct connection and make the necessary physical layer changes.

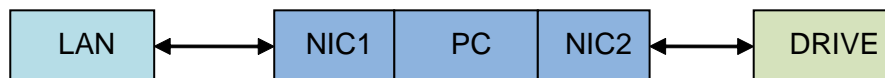

2. If you use a laptop and only connect to your LAN using wireless networking, you can use the built-in RJ45 Ethernet connection as your second NIC.

3. The factory default IP address of the drive is “192.168.1.10”.

4. To set the IP address of the second NIC:

a. On Windows XP, right click on “My Network Places” and select properties.

b. On Windows 7, click Computer. Scroll down the left pane until you see “Network”. Right click and select properties. Select “Change adapter settings”

5. You should see an icon for your newly instated NIC. Right click again and select properties.

a. Scroll down until you see “Internet Properties (TCP/IP)”. Select this item and click the Properties button.

b. On Windows 7 and Vista, look for “(TCP/IPv4)”

6. Select the option “Use the following IP address”. Then enter the address “192.168.1.11”. This will give your PC an IP address that is on the same subnet as the drive. Windows will know to direct any traffic intended for the drive's IP address to this interface card.

7. Next, enter the subnet mask as “255.255.255.0”. Be sure to leave “Default gateway” blank. This will prevent your PC from looking for a router on this subnet.

8. Because you are connected directly to the drive, anytime the drive is not powered on your PC will annoy you with a small message bubble in the corner of your screen saying “The network cable is unplugged.”

3.4 Inputs and Outputs

The TXM24 has three types of inputs:

- High speed digital inputs for step & direction commands or encoder following, 5 to 24 volt logic
- Low speed digital input for other signals, 5 to 24 volt logic
- Analog input for analog speed and positioning modes

All drives include 3 digital inputs and 1 analog input

- STEP & DIR are high-speed digital inputs for commanding position. Quadrature signals from encoders can also be used. When not being used for the Step & Direction function these inputs can be used for CW & CCW Limit, CW & CCW Jogging and Run/Stop & Direction Velocity modes.
- EN is a low speed software programmable input and can be used for Motor Enable and/or Alarm Reset. This input can also be connected to a sensor, switch or other device for use with Wait Input (WI), Seek Home (SH), Feed to Sensor (FS), On Input (OI) and other commands.
- AIN is an analog input for a velocity or position command signal. It can accept 0-5 volts and has gain, filtering, offset and dead-band settings.

3.4.1 Connector Pin Diagram

IO

Signal	Color of mating cable Phoenix P/N 1554775	Pin no.
Step+	BN	1
Step-	WH	3
Dir+	PK	5
Dir-	GY	8
En+	YE	6
En-	GN	4
OUT+	GYPK	11
OUT-	RDBU	12
+5V	RD	9
AIN	VT	10
GND	BK	7
N/C	BU	2

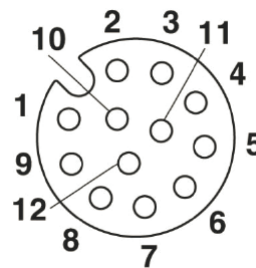

View of motor side connector

3.4.2 STEP & DIR Digital Inputs

The diagrams below show how to connect the STEP & DIR Inputs to various commonly used devices.

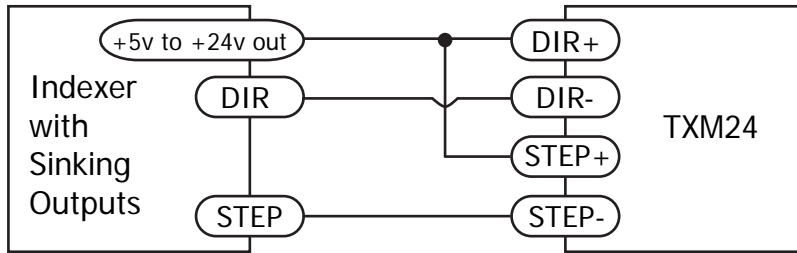

Connecting to Indexer with Sinking Outputs

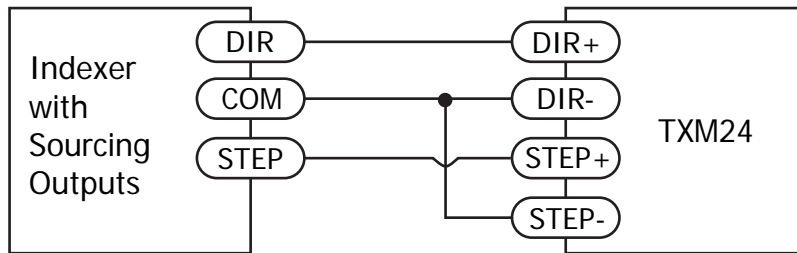

Connecting to Indexer with Sourcing Outputs

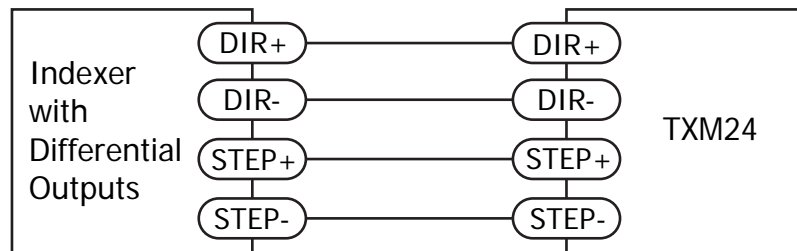

Connecting to Indexer with Differential Outputs
Many high-speed indexers have differential outputs

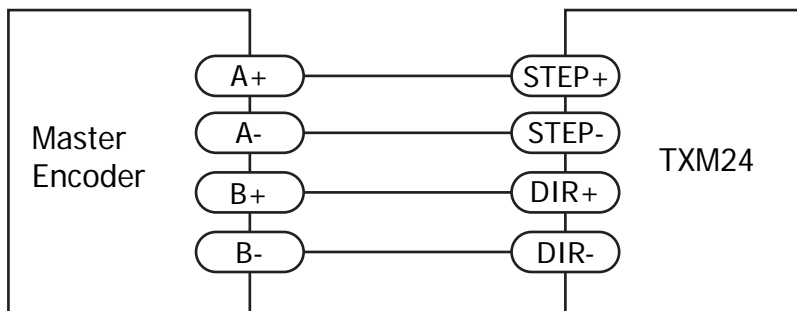

Wiring for Encoder Following

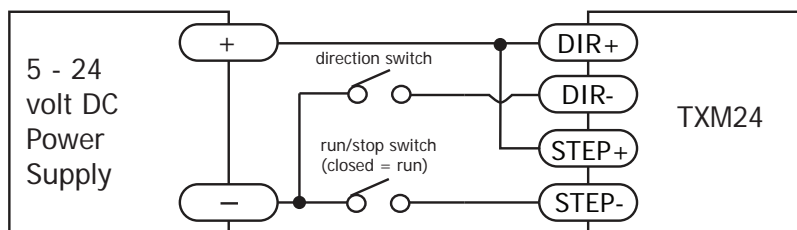

Using Mechanical Switches

3.4.3 EN Digital Input

While the STEP and DIR inputs are designed for high-speed digital input operation, the Enable (EN) input is designed for low speed digital input operation between 5 and 24 volts.

Note: If current is flowing into or out of an input, the logic state of that input is low or closed. If no current is flowing, or the input is not connected, the logic state is high or open.

The diagrams below show how to connect the EN input to various commonly used devices.

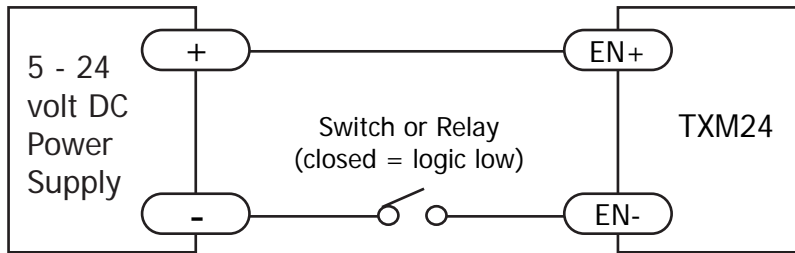

Connecting the Input to a Switch or Relay

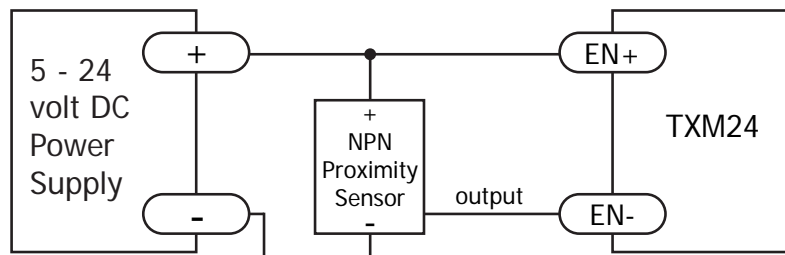

Connecting an NPN type Proximity Sensor to an Input
(when prox sensor activates, input goes low)

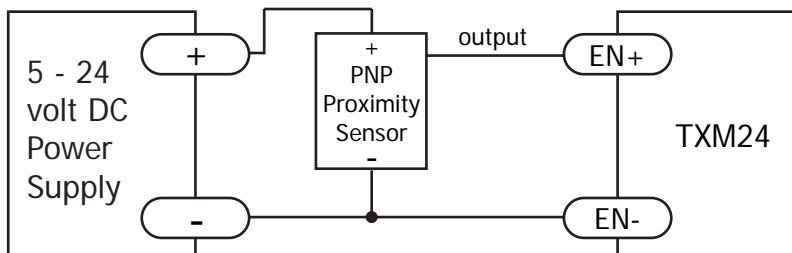

Connecting a PNP type Proximity Sensor to an Input
(when prox sensor activates, input goes high)

3.4.4 AIN Input

The TXM24 drives have an analog input (AIN) which can accept a signal range of 0 to 5 volts. The drive can be configured to operate at a speed or position that is proportional to the analog signal. Use the Step-Servo Quick Tuner software to set the signal range, offset, dead-band and filter frequency. The TXM24 provides a +5 volt 100mA limit voltage supply that can be used to power external devices such as potentiometers. It is not the most accurate supply for reference, for more precise readings use an external supply that can provide the desired accuracy.

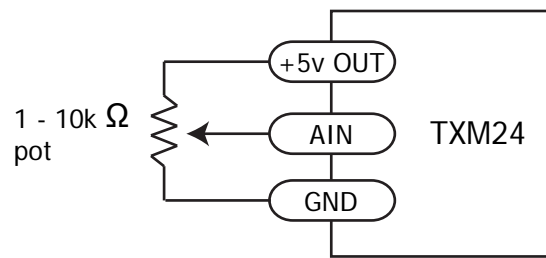
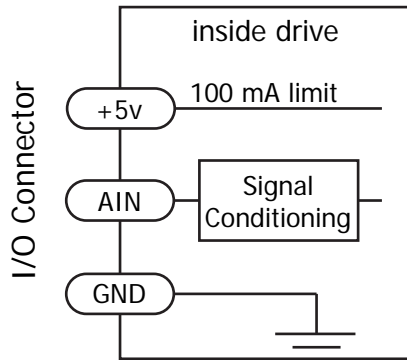

Connecting a Potentiometer to the Analog Input

3.4.5 Programmable Output

The TXM24 drives feature one optically isolated digital output (OUT). This output can be set to automatically control a motor brake, to signal a fault condition, to indicate when the motor is in position or to provide an output frequency proportional to motor speed (tach signal). Or the output can be turned on and off by program instructions like Set Output (SO). The output can be used to drive LEDs, relays and the inputs of other electronic devices like PLCs and counters. The OUT+ (collector) and OUT- (emitter) terminals of the transistor are available at the connector. This allows the output to be configured for current sourcing or sinking.

Diagrams of various connection types follow.

Do not connect the output to more than 30 volts. The current through the output terminal must not exceed 100mA.

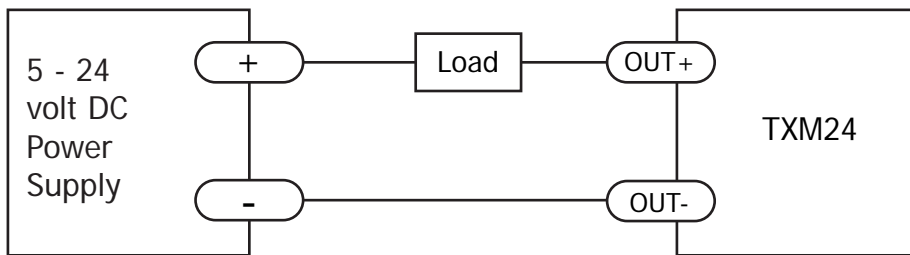

Connecting a Sinking Output

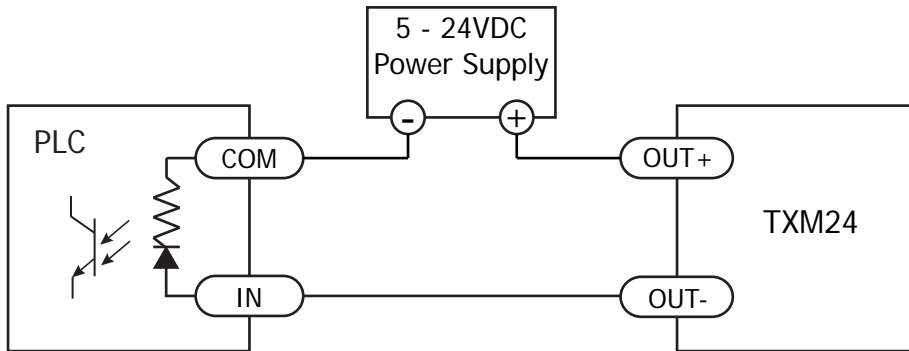

Connecting a Sourcing Output

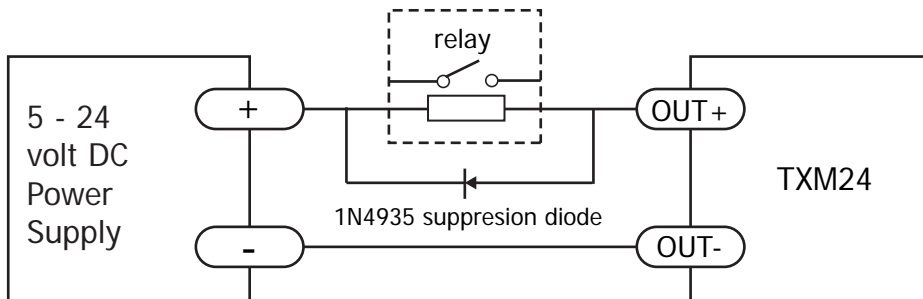

















Driving a Relay

4 Troubleshooting

LED Error Codes

The TXM24 uses bi-colour LED to indicate status. When the motor is enabled, the green LED flashes slowly. When the green LED is solid, the motor is disabled. Errors are indicated by combinations of red and green flashes as shown below. This feature can be disabled for certain warnings but not for alarms.

	Code	Error
	Solid green	No alarm, motor disabled
	Flashing green	No alarm, motor enabled
	1 red, 1 green	Motor stall (optional encoder only)
	2 red, 1 green	CCW limit
	2 red, 2 green	CW limit
	3 red, 1 green	Drive overheating
	3 red, 2 green	Internal voltage out of range
	3 red, 3 green	Blank Q segment
	4 red, 1 green	Power supply overvoltage or excess regen
	4 red, 2 green	Power supply undervoltage
	4 red, 3 green	Flash memory backup error
	5 red, 1 green	Over current/short circuit
	6 red, 1 green	Open motor winding
	6 red, 2 green	Bad encoder signal (optional encoder only)
	7 red, 1 green	Communication error
	7 red, 2 green	Flash memory error

5 Reference Materials

5.1 Torque-Speed Curves

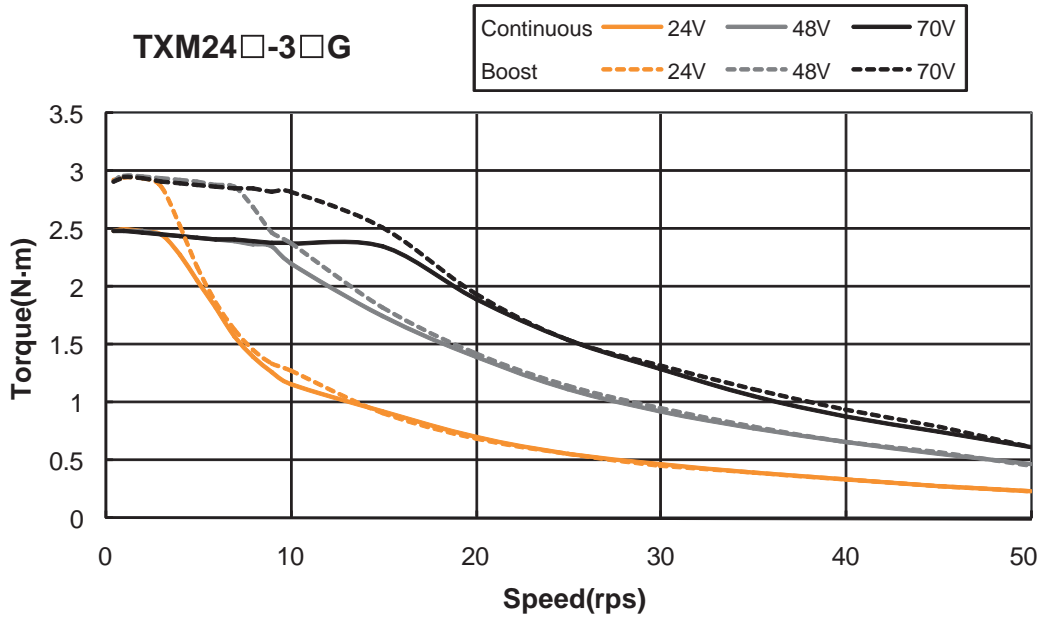

Note: all torque curves were measured at 20,000 steps/rev.

Note: 6 amp rating is continuous, 7.5 amp rating is boost

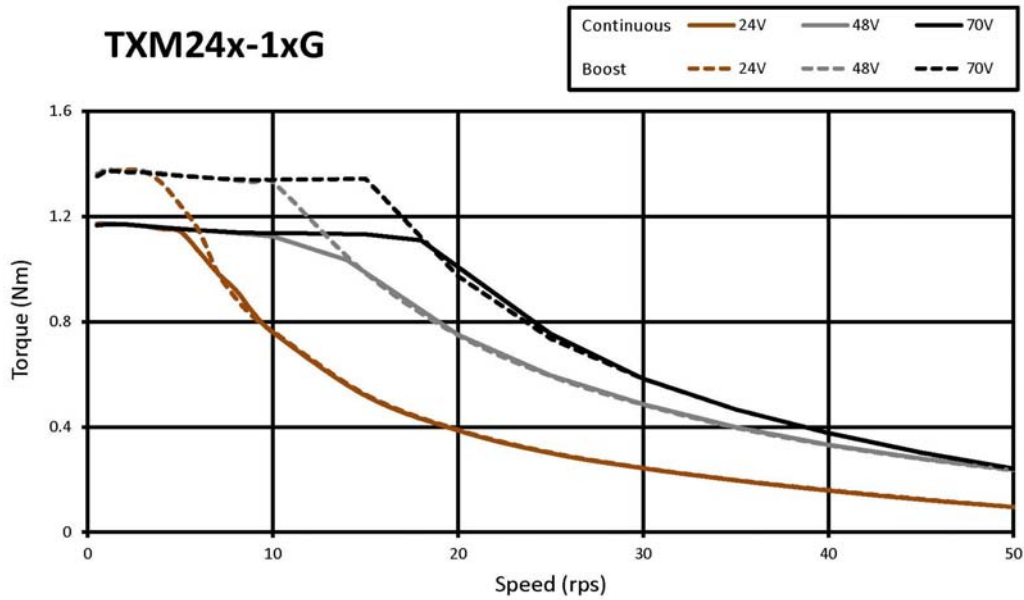

5.2 Mechanical Outlines

TXM24S/Q/IP-3EG

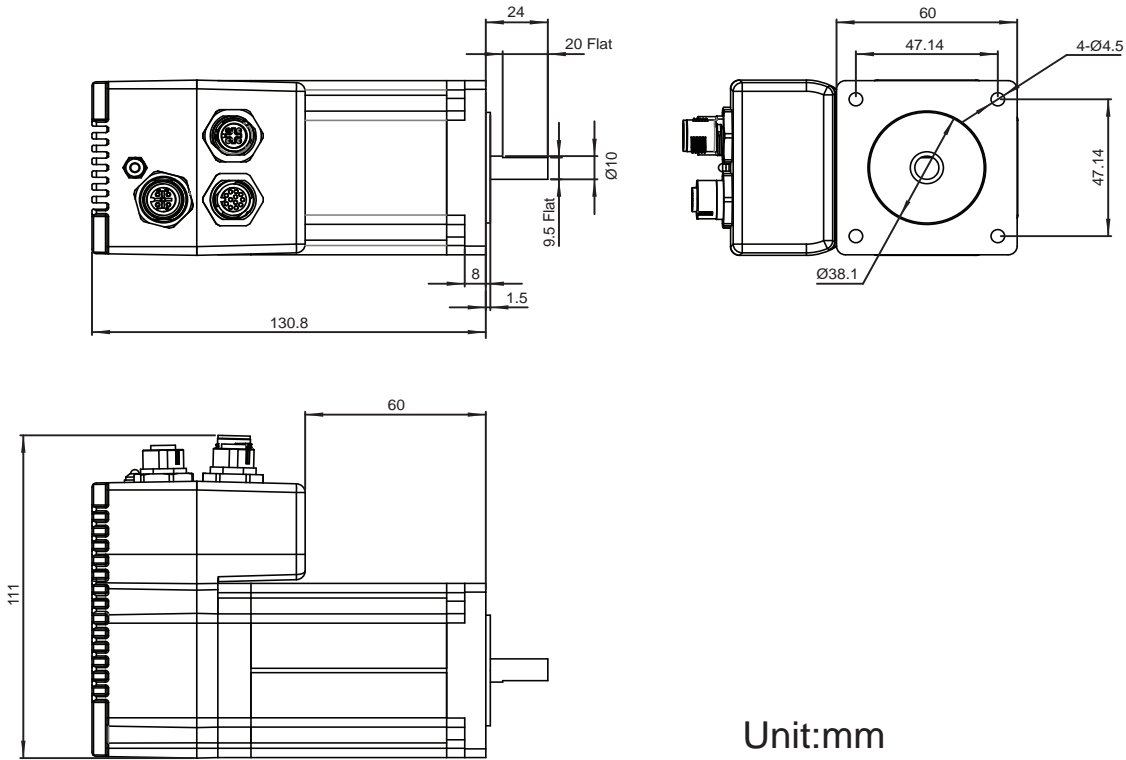

TXM24S/Q/IP-1EG

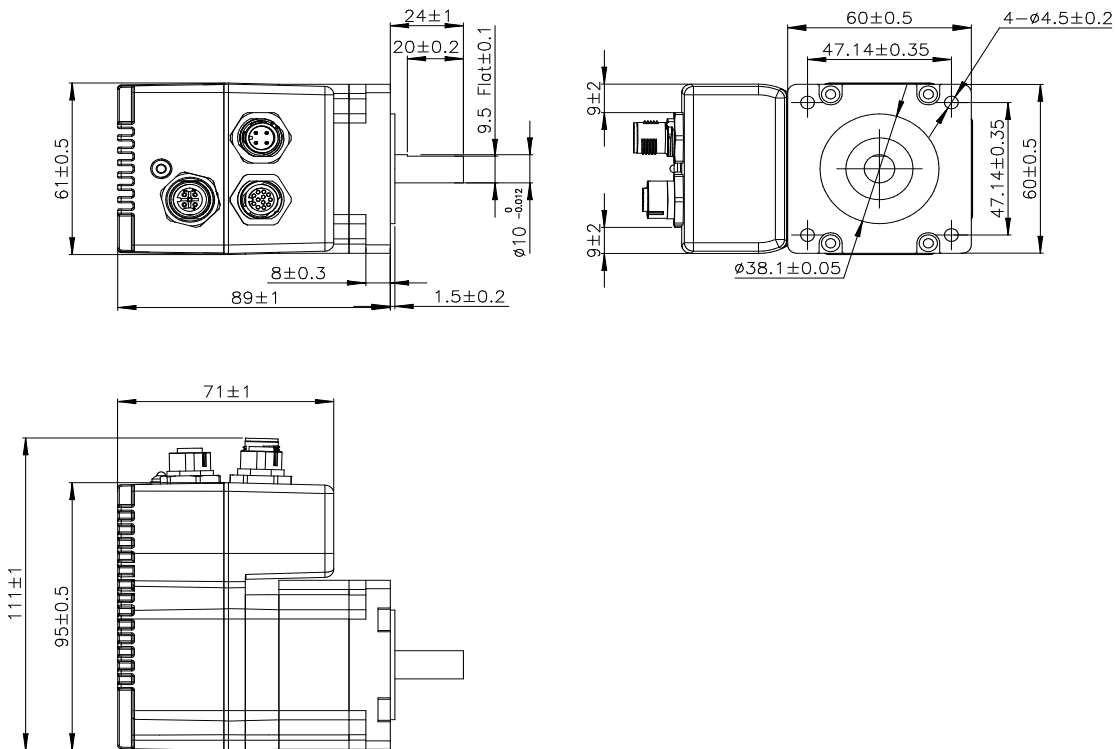

5.3 Technical Specifications

Power Amplifier	
Amplifier Type	Dual H-Bridge, 4 Quadrant
Current Control	4 state PWM at 20 KHz
Output Torque	TXM24S/Q/IP-3EG: Up to 2.4N•m Continuous (3.0 N•m Boost) TXM24S/Q/IP-1EG: Up to 0.82N•m Continuous (1.03 N•m Boost)
Power Supply	External 12 - 70 VDC power supply required
Protection	Over-voltage, under-voltage, over-temp, motor/wiring shorts (phase-to-phase, phase-to-ground)
Controller	
Electronic Gearing	Software selectable from 200 to 51200 steps/rev in increments of 2 steps/rev
Encoder Resolution	20000 counts/rev
Speed Range	Up to 3600rpm
Filters	Digital input noise filter, Analog input noise filter, Smoothing filter, PID filter, Notch filter
Non-Volatile Storage	Configurations are saved in FLASH memory on-board the DSP
Modes of Operation	TXM24S: Step & direction, CW/CCW pulse, A/B quadrature pulse, velocity (oscillator, joystick), streaming commands(SCL) TXM24Q/IP: All TXM24S modes of operation plus stored Q program execution
Digital Inputs	Digital Inputs Adjustable bandwidth digital noise rejection filter on all inputs STEP+/- : Optically isolated, 5-24 volt. Minimum pulse width = 250 ns, Maximum pulse frequency = 2 MHz Function: Step, CW step, A quadrature (encoder following), CW limit, CW jog, start/stop (oscillator mode), or general purpose input DIR+/- : Optically isolated, 5-24 volt. Minimum pulse width = 250 ns, Maximum pulse frequency = 2 MHz Function: Direction, CCW step, B quadrature (encoder following), CCW limit, CCW jog, direction (oscillator mode), or general purpose input EN+/- : Optically isolated, 5-24 volt. Minimum pulse width = 100 μ s, Maximum pulse frequency = 10 KHz Function: Enable, alarm/fault reset, speed 1/speed 2 (oscillator mode), or general purpose input
Digital Output	OUT+/- : Optically isolated, 30V/100 mA max. Function: Fault, tach, in position, brake, or general purpose programmable
Analog Input	AIN referenced to GND. Range = 0 to 5 VDC. Resolution = 12 bits
Communication Interface	Ethernet UDP/TCP, EtherNet/IP
Physical	
Ambient Temperature	0 to 40°C (32 to 104°F) When mounted to a suitable heatsink
Humidity	90% Max., non-condensing
Mass	TXM24S/Q/IP-3EG: 2000 g = 70.55 oz TXM24S/Q/IP-1EG: 1049 g = 37 oz
Rotor Inertia	TXM24S/Q/IP-3EG: 900 g•cm ² = 1.27 X 10 ⁻² oz-in-S ² TXM24S/Q/IP-1EG: 260 g•cm ² = 3.97E-03 oz-in-S ²
Length	TXM24S/Q/IP-3EG 5.15 inches (130.8mm) TXM24S/Q/IP-1EG 3.5 inches (88.9mm)

5.4 Accessories

Mating Cables

Position	Part Number	Description
Power	3004-277-5M	4-pin Mating Cable, M12, 2.0m, 22AWG, straight
I/O	3004-290-5M	12-pin Mating Cable, M12, 1.5m, 26AWG, straight
Ethernet	3004-280-5M	Bus system connector, plug, straight, 4-pos., M12 shielded, D-coded

6 Contacting Applied Motion Products

404 Westridge Dr.

Watsonville, CA 95076, USA

1-800-525-1609

Tel (831) 761-6555

Fax (831) 761-6544

www.applied-motion.com

